

Modulare Aggregatetechnik

TORNOS

WF
&

Werkzeugtechnik



**Katalog
TO-03**



Werkzeugtechnik

Kundenhinweise

Indications for the customer

Remarques suivantes

**Sehr geehrter Kunde,
bitte beachten Sie folgende Hinweise:**

- Mit diesem Katalog wird die vorherige Ausgabe ungültig
- Technische Änderungen und Irrtümer behalten wir uns vor
- Bildliche Darstellungen sind unverbindlich
- Für Druckfehler übernehmen wir keine Haftung
- Es gelten ausschließlich unsere allgemeinen Verkaufs- und Lieferbedingungen

**Dear Customer,
please note the following points:**

- This catalogue invalidates our former edition
- We reserve the right to make technical modifications and errors
- Pictorial illustrations are not binding
- We accept not any liability for print mistake
- Only our terms and conditions are valid

**Cher client,
veuillez considérer les indications suivantes:**

- Ce catalogue annule les précédentes publications
- Sous réserve de modifications techniques et d'erreurs
- Toutes les illustrations sont données à titre d'exemple et ne nous engagent en aucune manière
- Nous ne répondre pas aux fautes d'impression
- Seulement nos conditions de vente et de livraison sont valables

Inhaltsverzeichnis

Table of contents
Table des matières.



Werkzeugtechnik

Beschreibung / Description	Seite / Page
Rundlauf toleranzen Runout tolerances	1.2
Gebrauch und Wartung der WFB-Schnittstelle Handling and maintenance for WFB connection	1.3
Produktvorteile der WFB-Schnittstelle Product advantages of WFB connection	1.4
WFB Produktübersicht (Auszug) WFB Product overview	1.6
Modularer Gewindewirbelkopf Thread whirling head modular	1.8
TORNOS - EvoDECO	7.1 - 7.35
TORNOS - Gamma	7.36 - 7.42
TORNOS - Swiss Baureihen	7.43 - 7.53
WFB statische Halter WFE/SHT WFB static holders WFE/SHT	9
WF Micro – Modulare Drehhalter WF-Micro modular turning holders	10
WFB – Adapter und Zubehör WFB – adapter and accessories	11
Allgemeine Verkaufs- und Lieferbedingungen General sales terms and delivery conditions	12

WG = Warengruppe
Article group
Groupe de marchandise

WG 11 = _____

WG 35 = _____

WG 40 = _____

Rundlauftoleranzen

Runout tolerances
Tolérance de rotation

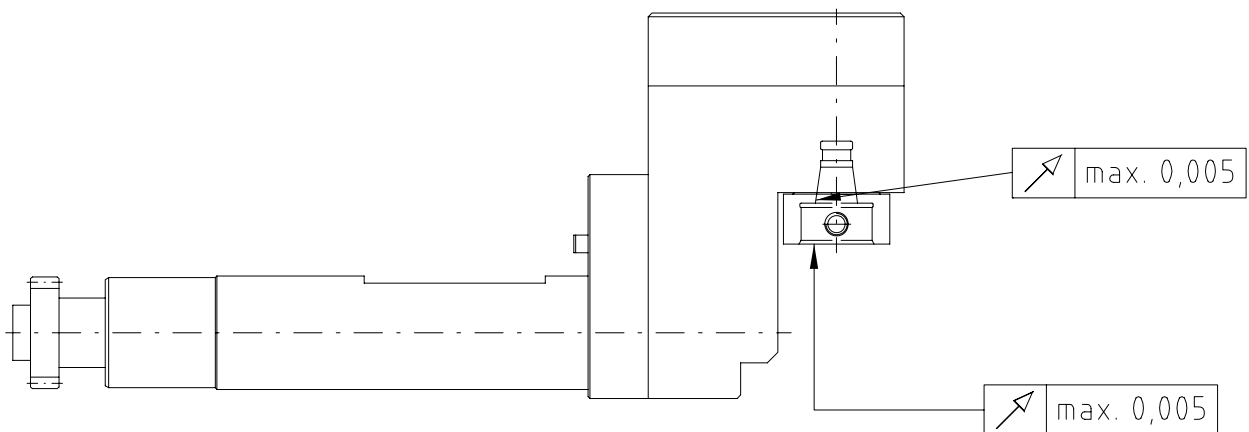
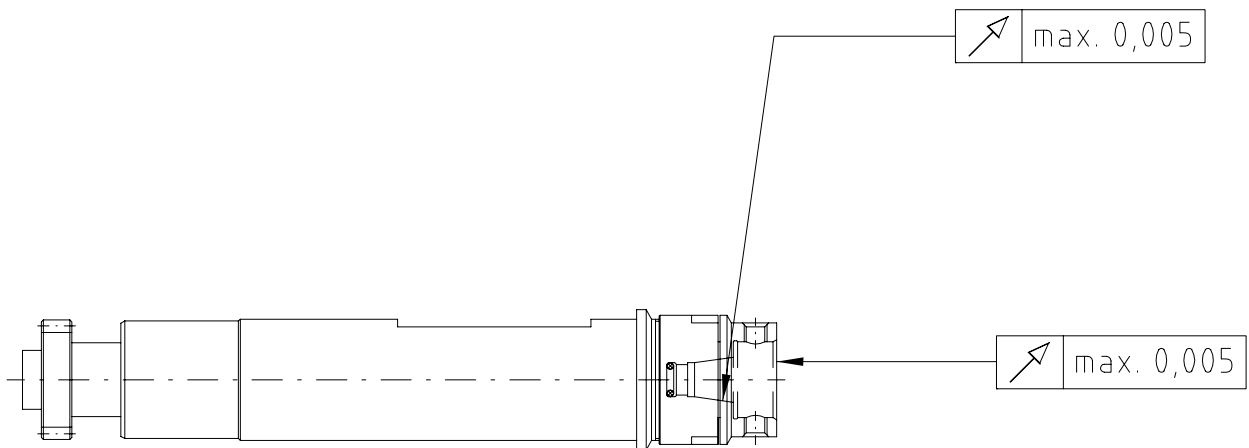

Gebrauch und Wartung der WFB-Schnittstelle

Handling and maintenance for WFB connection
Manutention et maintenance pour WFB connexion



Werkzeugtechnik

Hinweis zur Befestigung

Zunächst einen Kegelgewindestift anziehen, dabei 1-2 mal lösen und wieder anziehen. Dadurch wird eine optimale Positionierung der Bauteile erreicht. Der 2. Kegelgewindestift wird nun ebenfalls (wie oben angeführt) angezogen. Empfohlene Drehmomente entnehmen Sie der unteren Tabelle.

Advice for fixing

First tighten one threaded taper pin, in doing so 1 or 2 times unscrew and tighten again. Thereby you get an optimum positioning of the components. The second threaded taper pin you will tighten with the same method. Recommended locking torque see in the lower table.

Pflege und Wartung

Die Oberflächen der Planflächen, der Kegelbohrung und Kegelzapfen sind vor Gebrauch zu reinigen und mit einem Öl-Schmierfilm zu versehen. Um eine optimale Befestigung und Lösbarkeit der Kegelgewindestifte zu erreichen, wird empfohlen die Kegelgewindestifte mit z.B. Molykote 1000 oder einer ähnlichen Heiss-Schraubenpaste zu behandeln.

Support and maintenance

The surface of the face, the cone drill and cone pin must be cleaning and lubricate with oil before using. To reach an optimum fixing and resolvability of the threaded taper pins, are recommended to use for example Molykote 1000 or something similar.

Empfohlene Anzugsdrehmomente

Recommended locking torque / Retenue couple

Größe	Kegelgewindestifte	Anzugs-Drehmoment
WFB20-12	M6 x 0,75 / Torx 15 Plus	4 Nm
WFB20-12	M6 x 1 / Torx T15	4 Nm
WFB24-16	M8 x 1 / Torx T25	10 Nm
WFB 32-20	M10 x 1	20 Nm

Empfohlene Anzugsdrehmomente beim Einsatz von Kontrollidornen

Recommended locking torque when running test arbors

Retenue couple à l'usage de Mandrins de contrôle

Größe	Kegelgewindestifte	Anzugs-Drehmoment
WFB20-12	M6 x 0,75 / Torx 15 Plus	2 Nm
WFB20-12	M6 x 1 / Torx T15	2 Nm
WFB24-16	M8 x 1 / Torx T25	5 Nm
WFB 32-20	M10 x 1	10 Nm

Produkt-Vorteile der WFB-Schnittstelle

Vorteile auf einen Blick:

Wirtschaftlich

Durch den Einsatz von Werkzeugen, die parallel zur Maschinenlaufzeit voreingestellt werden, reduziert sich die Maschinenrüstzeit nahezu auf Null. Teure Maschinenstillstandzeiten werden vermieden.

Präzise

Die Kegel/Plananlage mit zylindrischer Abstützung gewährleistet höchste Genauigkeit und absoluten Formschluß.

Bedienerfreundlich

- Keine Verletzung der Hände.
- Kein Risiko, die Werkzeuglager durch das Einschrauben von Spannfuttern zu beschädigen.
- Geringes Risiko, den teuren Werkzeughalter beim Ein- und Ausbau zu beschädigen.
- Präzise Werkzeugvoreinstellung außerhalb der Maschine.
- Genaues und wiederholbares Spannen des Adapters mit definiertem Drehmoment.

Flexibel

- Verwendung unterschiedlicher Spanntechnologien auf einem gleichbleibenden Halter.
- Für jeden Bearbeitungsvorgang lässt sich das optimale Spannsystem anwenden.
- Weniger unterschiedliche angetriebene Werkzeuge von Nöten.
- Adapter auf angetriebenen und auch auf statischen Werkzeugen einsetzbar.

Merkmale der WFB-Schnittstelle

- große Plananlage bildet zusammen mit Kegelmantel Formschluss.
- stabiler „Vollkegel-Mantel“ sorgt für enorme Steifigkeit.
- Abstützbund verhindert Axialbewegung des Kegels bei Radialbelastungen.
- zylindrischer Absatz zur Unterbringung des Spannsystems.
- sicherer und einfacher Spannsystem durch zwei spezielle Kegelgewindestifte.
- Stellgewinde zur Einstellung der Werkzeuglänge.
- Adapter dank Kühlmittelbohrung bereit für die Verwendung mit Innenkühlung.

WFB

Hochpräzisions-Schnellwechselsystem für Drehmaschinen



Besuchen Sie uns

W&F Werkzeugtechnik GmbH



Kantstr. 4
72663 Großbottlingen
Deutschland

info@wf-werkzeugtechnik.de
www.wf-werkzeugtechnik.de

Product- advantages of WFB-Connection

The advantages at a glance:

Economical

By using tools that are preset parallel to the machine running time, the machine set-up time is reduced to almost zero. Expensive machine downtimes are avoided.

Precise

The cone/face contact with cylindrical support ensures the highest level of accuracy and an absolute form fit.

User friendly

- no injury to hands.
- no risk of damaging tool bearings by screwing in chucks.
- low risk of damaging the expensive tool holder during installation and removal.
- precise tool presetting outside the machine.
- accurate and repeatable clamping of the adapter with defined torque.

Flexible

- use of different clamping technologies on one consistent holder.
- the optimum clamping system can be selected for every machining process.
- fewer different power tools required.
- adapters on driven and also on static tools usable.

Features of the WFB interface

- large flat contact forms a form fit together with the cone shell.
- stable "full cone jacket" ensures enormous rigidity.
- support collar prevents axial movement of the cone under radial loads.
- cylindrical shoulder to accommodate the tensioning mechanism.
- safe and simple clamping mechanism thanks to two special taper thread pins.
- adjusting thread for setting the tool length.
- adapter ready for use with internal cooling thanks to coolant hole.

WFB

high-precision quick-change system for swiss-type machines



visit us



W&F Werkzeugtechnik GmbH

Kantstr. 4
72663 Großbettlingen
Germany

info@wf-werkzeugtechnik.de
www.wf-werkzeugtechnik.de



Werkzeugtechnik

WFB - Produktübersicht (Auszug)

WFB - Product overview
WFB - Vue d'ensemble de produit

WFB - Aggregate

WFB - Aggregates

WFB - Agrégats

Axial

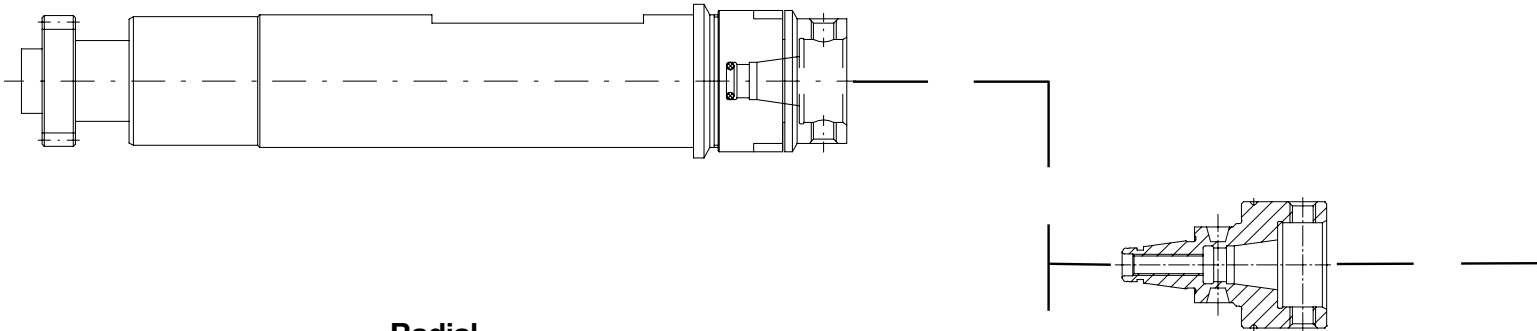

Radial

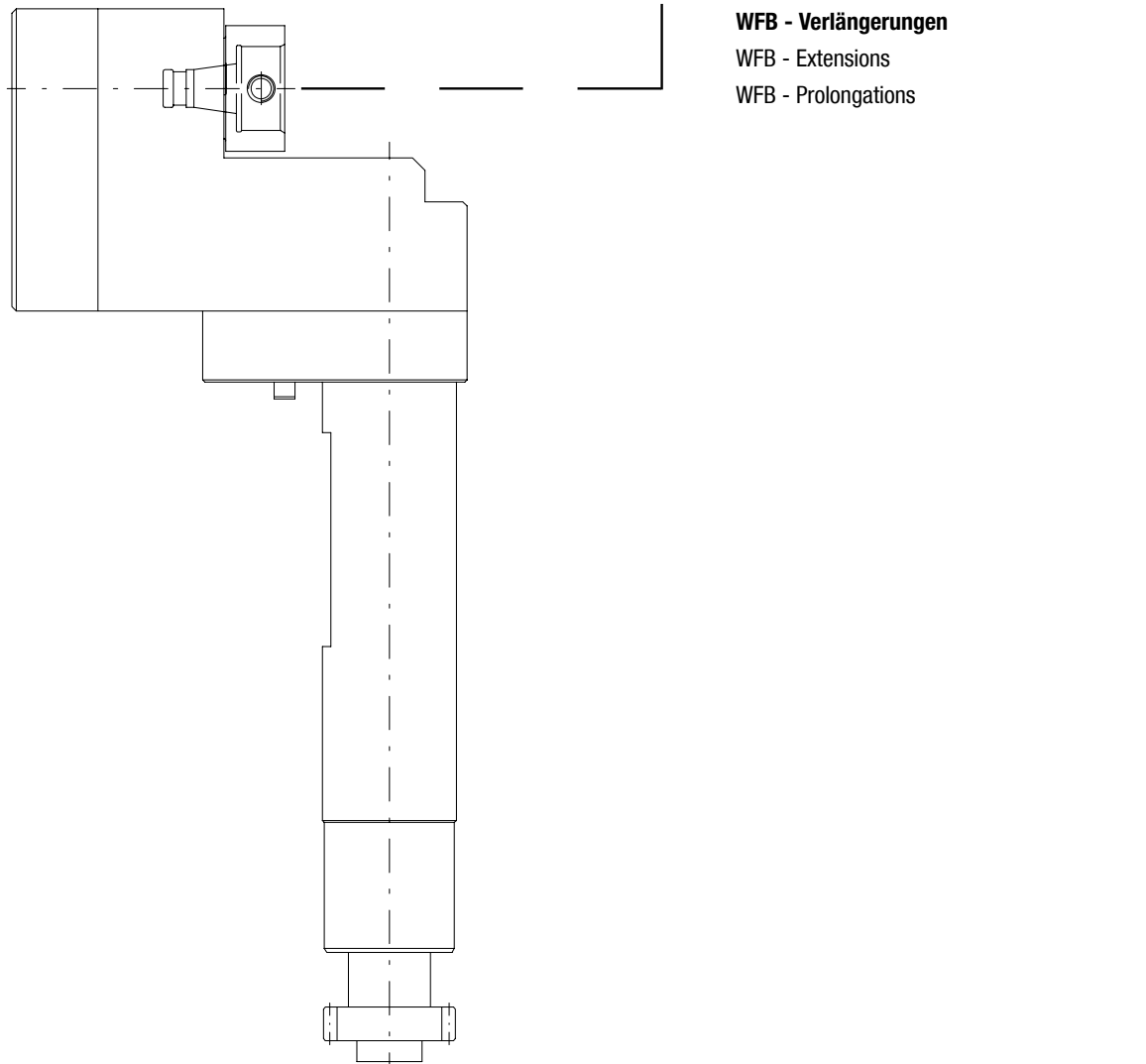

WFB - Verlängerungen

WFB - Extensions

WFB - Prolongations

WFB - Produktübersicht (Auszug)

WFB - Product overview
WFB - Vue d'ensemble de produit

WFB

Werkzeugtechnik

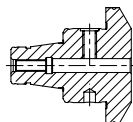

WFB - Weldon / Whistle Notch für Zylinderschäfte DIN 1835 B / E

WFB - Weldon / Whistle Notch for parallel shanks

WFB - Weldon / Whistle Notch pour queues cylindriques

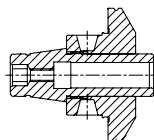

WFB - Schrumpffutter

WFB - Shrink fit chucks

WFB - Mandrins de frettage

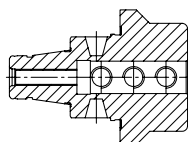

WFB - Bohrstangenhalter

WFB - Boring bar holder

WFB - Porte-outil pour barres d'alésage

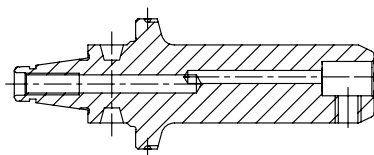

WFB - Klemmhalter W-T HORN Supermini® mit IKZ

WFB - Toolholder W-T HORN Supermini® with internal cooling system

WFB - Porte-outil W-T HORN Supermini® avec arrosage central

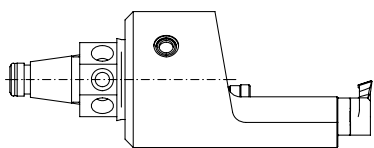

WFB - Klemmhalter W-T HORN Mini mit IKZ

WFB - Toolholder W-T HORN Mini with internal cooling system

WFB - Porte-outil W-T HORN Mini avec arrosage central

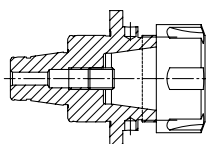

WFB - Spannzangenfutter 8° Typ ER

WFB - Collet chucks 8° type ER

WFB - Mandrins porte-pinces 8° type ER

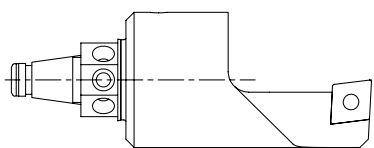

WFB - Drehhalter W-T mit IKZ

WFB - Turning tool holder W-T with internal cooling system

WFB - Rotatif porte-outil W-T avec arrosage central

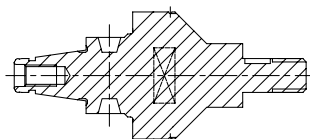

WFB - Sägeblattaufnahmen

WFB - Tool holders for saw blade

WFB - Mandrins pour lame de scie

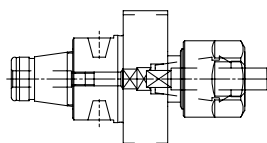

WFB - Softsynchro® mit IKZ

WFB - Softsynchro® with internal cooling system

WFB - Softsynchro® avec arrosage central

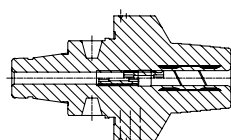

WFB - Hydro-Dehnspannfutter

WFB - Hydraulic expansion chuck

WFB - Mandrin hydraulique

Modularer Wirbelkopf

Stillstandszeiten senken durch modulare Gewindewirbelköpfe



Der Ein- und Ausbau des Wirbelapparates sowie das damit verbundene Ausrichten, gehört durch den Einsatz modularer Gewindewirbelinheiten der Vergangenheit an. Durch die hohe Rundlaufgenauigkeit der Schnittstelle und der gleichmäßigen Abnutzung der Schneidplatten, kann eine Standzeiterhöhung von bis zu 300% erreicht werden.

- Wechseln des Einsatzes: < 1 min
- Rundlaufgenauigkeit: < 3 μ
- Wechselwiederholgenauigkeit: < 2 μ
- Voreinstellbar außerhalb der Maschine
- Verfügbar für alle gängigen Langdrehmaschinen

Durch das Zusammenspiel von Kegel-Plananlage mit Zylindrischem Bund, erreichen wir nicht nur höchste Genauigkeit in der Schnittstelle, sondern auch ein bedienerfreundliches Wechseln der Einsätze mit lediglich drei Schrauben.

Unser Rohlingsprinzip bietet höchste Flexibilität und die Möglichkeit, Ihre benötigten bzw. bevorzugten Wendeschneidplatten zu verwenden. Die entsprechenden Plattensitze können vom Wendepplattenhersteller oder auch von Ihnen selbst in den Rohling eingebracht werden.



Modular thread whirling head

Reduce machine downtimes by modular thread whirling heads

WF
&

Werkzeugtechnik



By the use of the modular thread whirling head, the mounting and dismounting of the unit out of the machine and the steady adjustment, are now things of the past. Though the high rotation accuracy of the interface and the even wear of the cutting edges, tool endurance can be increased up to 300%.

- change of the insert: < 1 min
- true running accuracy: < 3 μ
- change accuracy: < 2 μ
- pre adjustable outside of the machine
- available for common swiss-type machines

Through the interplay of cone-shaped shell and planned assets with cylindrical support, we not only reach highest preciseness in the interface it self, but also an user-friendly changing of the inserts with only three screws

Our “blanks-principle“ enables highest flexibility and the opportunity to use your needed respectively your preferred insert tips. The according insert seats can be made by the manufacturer of the insert tips, or by your self as well.

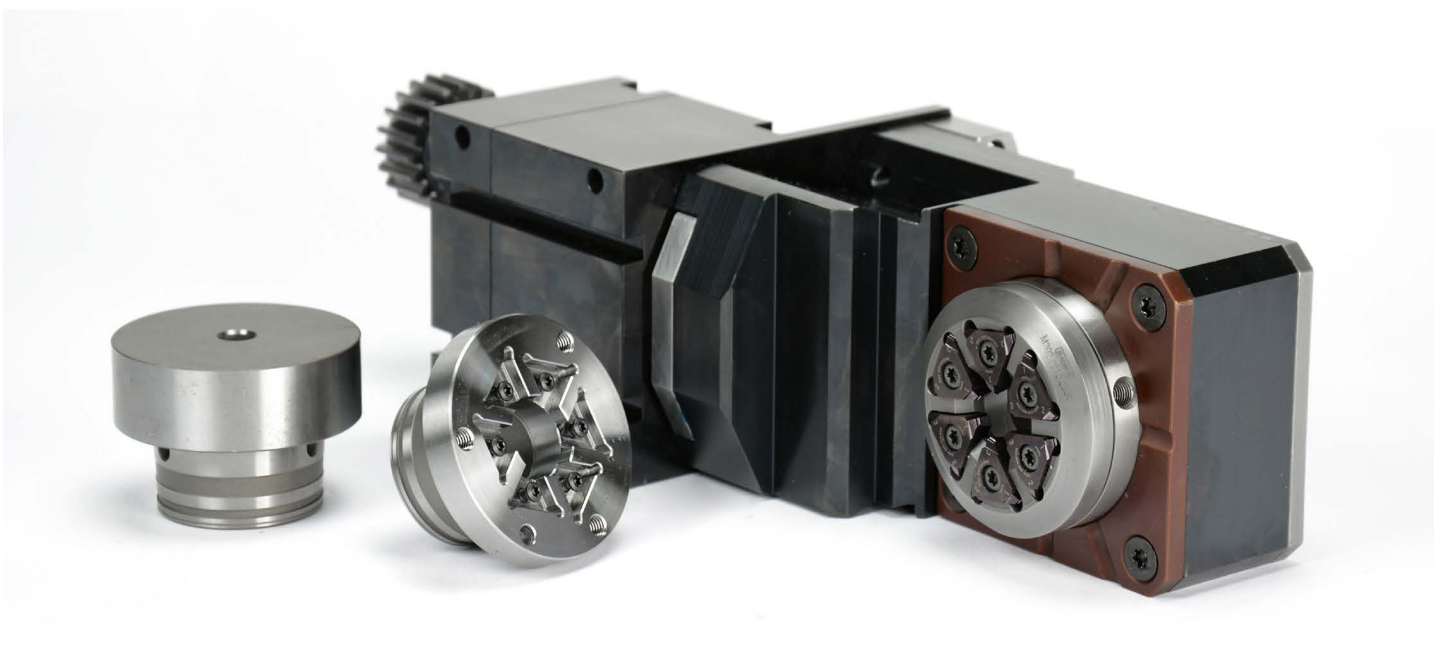

Modulare Aggregatetechnik

TORNOS

WF
&

Werkzeugtechnik



**Katalog
TO-03**



Werkzeugtechnik

Inhaltsverzeichnis für TORNOS

Table of contents for TORNOS
Table des matières pour TORNOS

Beschreibung / Description	Seite / Page
TORNOS – EvoDECO	7.1 - 7.35
TORNOS – Gamma	7.36 - 7.42
TORNOS – Swiss Baureihen	7.43 - 7.53

Tornos - EvoDECO

Axial Bohr- und Fräskopf

Axial drilling and milling head

Outil de perçage et de fraisage axiale

WG 35

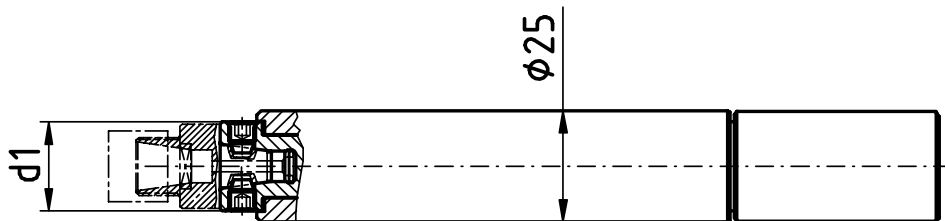

[mm]	Spindle Broche Spindel	[Nm] T max	[rpm] n max	i	Outside cooling Lubrificat. ext. Aussenkühlung	Internal cooling Lubrificat. cent. Innenkühlung	[bar] p	Order no. N° de Code Bestellnummer
20	WF-Micro	6	12.000	1:1				MPU.TO.WFM.0110.DE10

Passend für Maschine:	DECO 10
suitable machines:	EvoDECO 10/10
approprié pour la machine:	EvoDECO 10/8

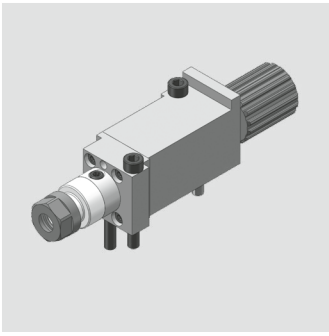

Tornos - EvoDECO

Axial Bohr- und Fräskopf
 Axial drilling and milling head
 Outil de perçage et de fraisage axiale

WG 35

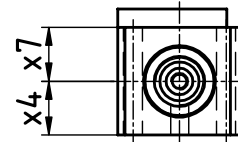
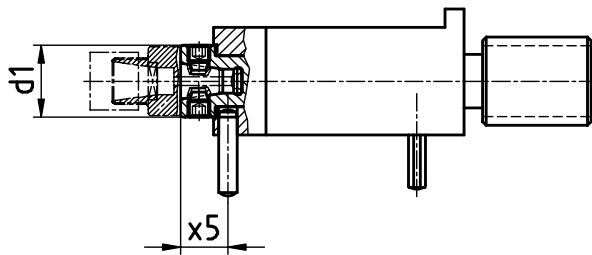

[mm]	[mm]	[mm]	[mm]	Spindle Broche	[Nm]	[rpm]		Outside cooling Lubrificat. ext.	Internal cooling Lubrificat. cent.	[bar]	Order no. N° de Code
d1	x4	x5	x7	Spindel	T max	n max	i	Aussenkühlung	Innenkühlung	p	Bestellnummer
20	15	13	15	WF-Micro	6	12.000	1:1				MPU.TO.WFM.0115.DE10

Passend für Maschine:	DECO 10
suitable machines:	EvoDECO 10/10
approprié pour la machine:	EvoDECO 10/8

Tornos - EvoDECO

Radial Bohr- und Fräskopf

Radial drilling and milling head

Outil de perçage et de fraisage radiale

WG 35

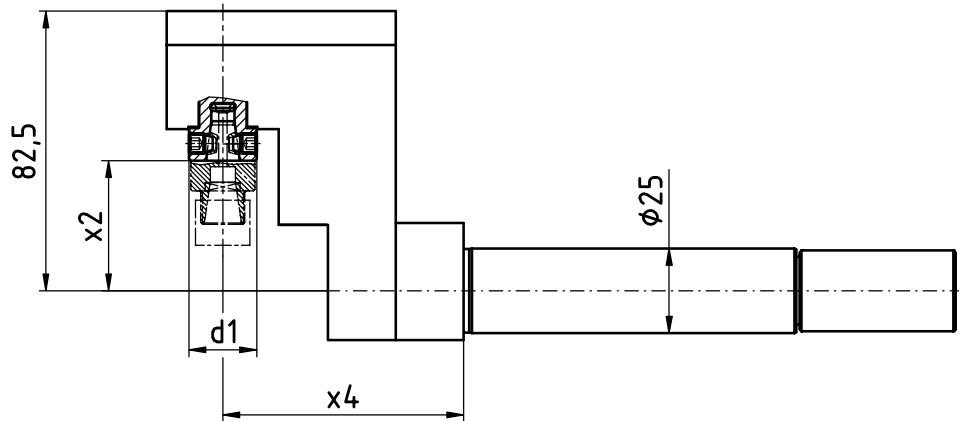
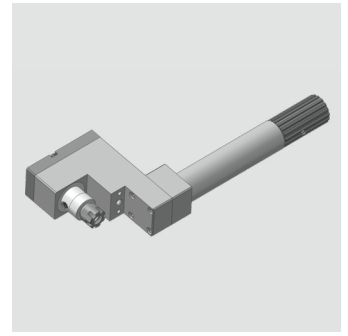

[mm]	[mm]	[mm]	Spindle Broche	[Nm]	[rpm]		Outside cooling Lubrificat. ext.	Internal cooling Lubrificat. cent.	[bar]	Order no. N° de Code
d1	x2	x4	Spindel	T max	n max	i	Aussenkühlung	Innenkühlung	p	Bestellnummer
20	38,4	71	WF-Micro	6	12.000	1:1				MPU.TO.WFM.0210.DE10

Passend für Maschine:	DECO 10
suitable machines:	EvoDECO 10/10
approprié pour la machine:	EvoDECO 10/8

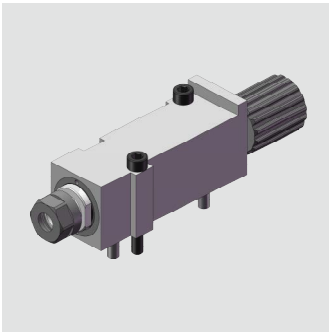

Tornos - EvoDECO

Axial Bohr- und Fräskopf
 Axial drilling and milling head
 Outil de perçage et de fraisage axiale

WG 35

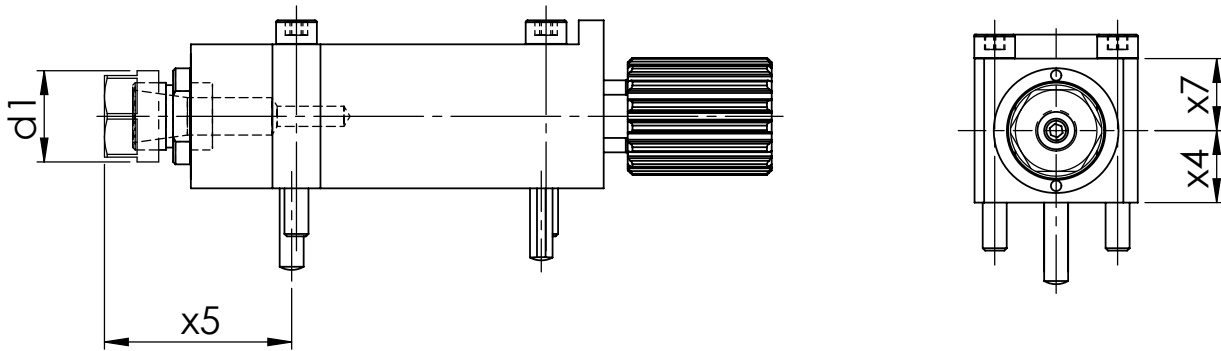

[mm]	[mm]	[mm]	[mm]	Spindle Broche	[Nm]	[rpm]		Outside cooling Lubrificat. ext.	Internal cooling Lubrificat. cent.	[bar]	Order no. N° de Code
d1	x4	x5	x7	Spindel	T max	n max	i	Aussenkühlung	Innenkühlung	p	Bestellnummer
19	15	39	15	ER11	6	12.000	1:1				MPU.TO.0115.DE10
19	30	39	15	ER11	6	12.000	1:1				MPU.TO.0130.DE10

Passend für Maschine:	DECO 10
suitable machines:	EvoDECO 10/10
approprié pour la machine:	EvoDECO 10/8

Tornos - EvoDECO

Radial Bohr- und Fräskopf

Radial drilling and milling head

Outil de perçage et de fraisage radiale

WG 35

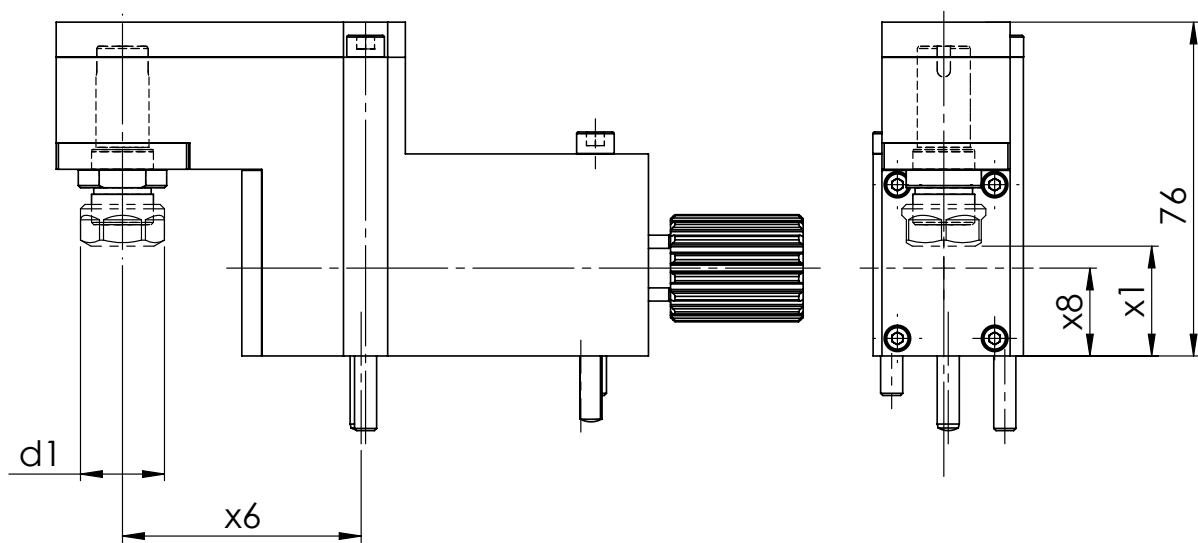
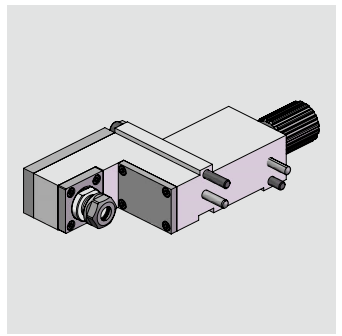

[mm]	[mm]	[mm]	[mm]	Spindle Broche	[Nm]	[rpm]		Outside cooling Lubrificat. ext.	Internal cooling Lubrificat. cent.	[bar]	Order no. N° de Code
d1	x1	x6	x8	Spindel	T max	n max	i	Aussenkühlung	Innenkühlung	p	Bestellnummer
19	25	54	20	ER11	6	12.000	1:1				MPU.TO.0200.DE10

Passend für Maschine:	DECO 10
suitable machines:	EvoDECO 10/10
approprié pour la machine:	EvoDECO 10/8

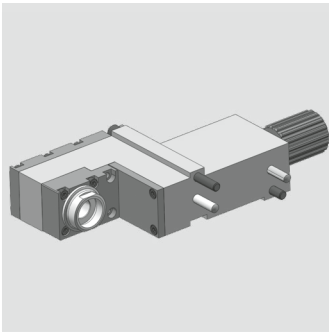

Tornos - EvoDECO

Radial Bohr- und Fräskopf
 Radial drilling and milling head
 Outil de perçage et de fraisage radiale

WG 35

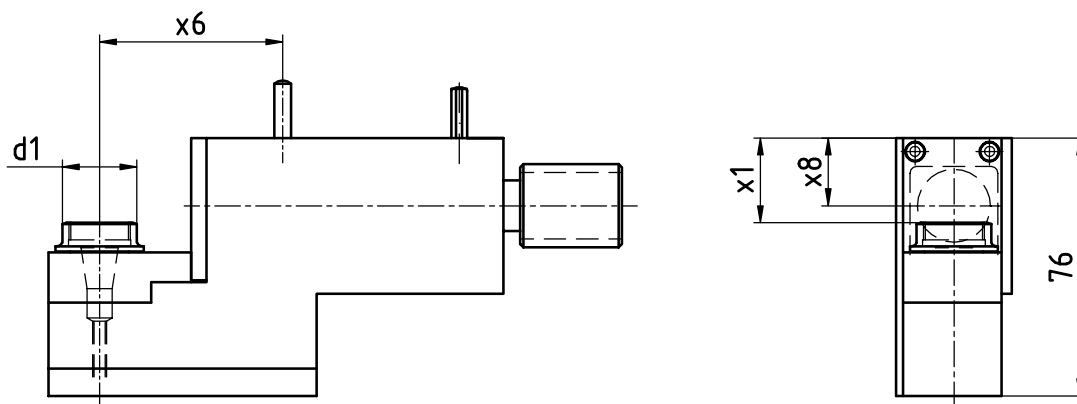

[mm]	[mm]	[mm]	[mm]	Spindle Broche	[Nm]	[rpm]		Outside cooling Lubrificat. ext.	Internal cooling Lubrificat. cent.	[bar]	Order no. N° de Code
d1	x1	x6	x8	Spindel	T max	n max	i	Aussenkühlung	Innenkühlung	p	Bestellnummer
22	25	54	20	ER11	6	12.000	1:1				MPU.TO.0200.DE10.X2

Passend für Maschine:	DECO 10
suitable machines:	EvoDECO 10/10
approprié pour la machine:	EvoDECO 10/8

Tornos - EvoDECO

Axial Bohr- und Fräskopf

Axial drilling and milling head

Outil de perçage et de fraisage axiale

WG 35

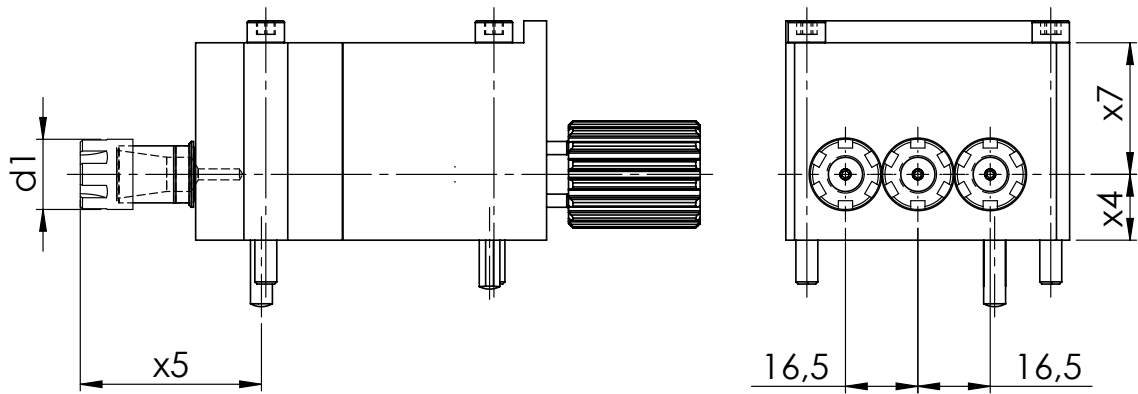
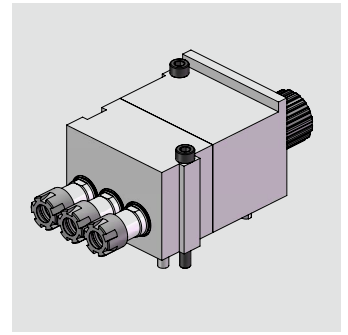

[mm]	[mm]	[mm]	[mm]	Spindle Broche	[Nm]	[rpm]		Outside cooling Lubrificat. ext.	Internal cooling Lubrificat. cent.	[bar]	Order no. N° de Code
d1	x4	x5	x7	Spindel	T max	n max	i	Aussenkühlung	Innenkühlung	p	Bestellnummer
16	30	41,3	15	ER11 MINI	5	12.000	1:1				MPU.TO.1103.DE10
16	15	41,3	30	ER11 MINI	5	12.000	1:1				MPU.TO.1203.DE10

Passend für Maschine:	DECO 10
suitable machines:	EvoDECO 10/10
approprié pour la machine:	EvoDECO 10/8

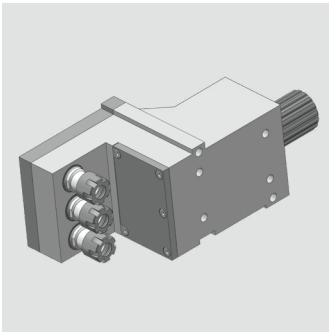

Tornos - EvoDECO

Radial Bohr- und Fräskopf
 Radial drilling and milling head
 Outil de perçage et de fraisage radiale

WG 35

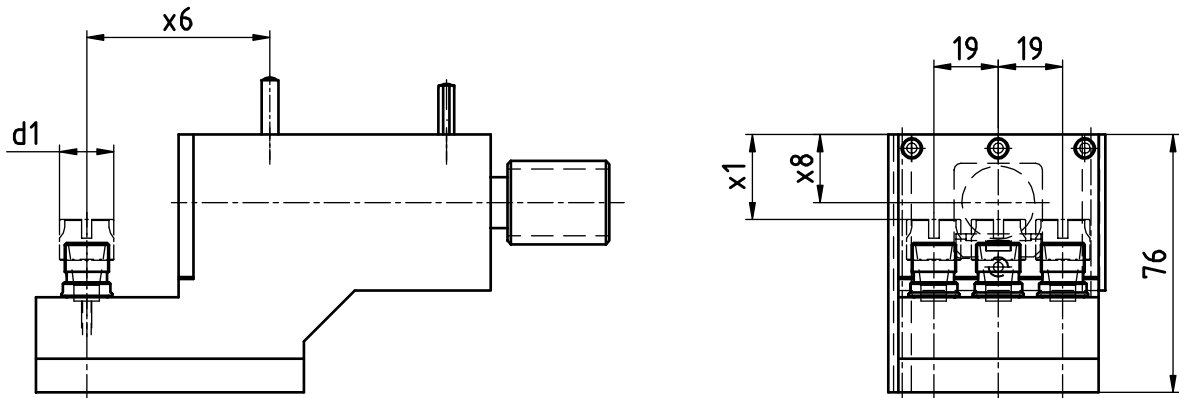

[mm]	[mm]	[mm]	[mm]	Spindle Broche	[Nm]	[rpm]		Outside cooling Lubrificat. ext.	Internal cooling Lubrificat. cent.	[bar]	Order no. N° de Code
d1	x1	x6	x8	Spindel	T max	n max	i	Aussenkühlung	Innenkühlung	p	Bestellnummer
16	25	54	20	ER11 MINI	6	12.000	1:1				MPU.TO.2103.DE10

Passend für Maschine:	DECO 10
suitable machines:	EvoDECO 10/10
approprié pour la machine:	EvoDECO 10/8

Tornos - EvoDECO

Axial Bohr- und Fräskopf

Axial drilling and milling head

Outil de perçage et de fraisage axiale

WG 35

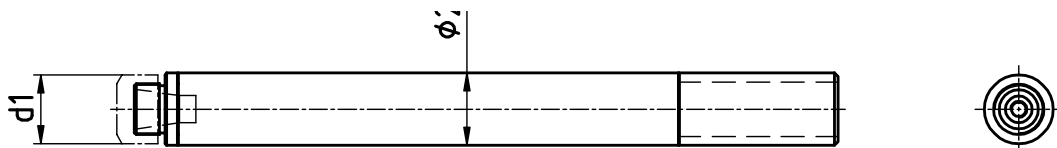

[mm]	Spindle Broche Spindel	[Nm] T max	[rpm] n max		Outside cooling Lubrificat. ext. Aussenkühlung	Internal cooling Lubrificat. cent. Innenkühlung	[bar] p	Order no. N° de Code Bestellnummer
19	ER11	6	12.000	1:1				MPU.TO.0120.DE10

Passend für Maschine:	DECO 10
suitable machines:	EvoDECO 10/10
approprié pour la machine:	EvoDECO 10/8



Tornos - EvoDECO

Axial Bohr- und Fräskopf
 Axial drilling and milling head
 Outil de perçage et de fraisage axiale

WG 35

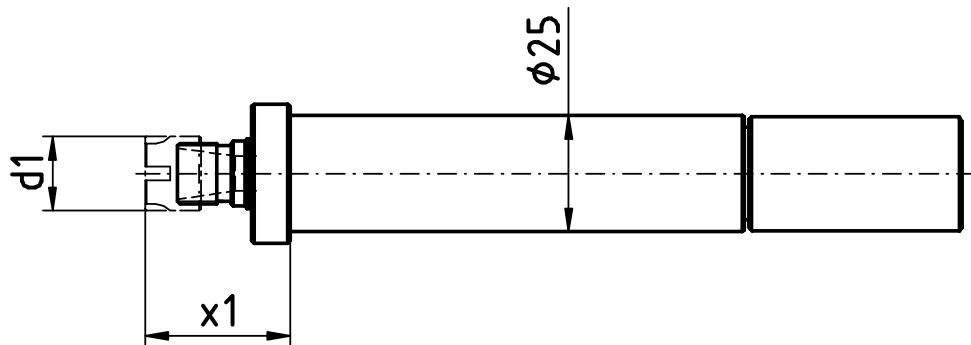

[mm]	[mm]	Spindle Broche Spindel	[Nm] T max	[rpm] n max	i	Outside cooling Lubrificat. ext. Aussenkühlung	Internal cooling Lubrificat. cent. Innenkühlung	[bar] p	Order no. N° de Code Bestellnummer
d1	x1								
16	31,3	ER11 MINI	6	12.000	1:1				MPU.TO.0110.DE10

Passend für Maschine:	DECO 10
suitable machines:	EvoDECO 10/10
approprié pour la machine:	EvoDECO 10/8

Tornos - EvoDECO

Radial Bohr- und Fräskopf

Radial drilling and milling head

Outil de perçage et de fraisage radiale

WG 35

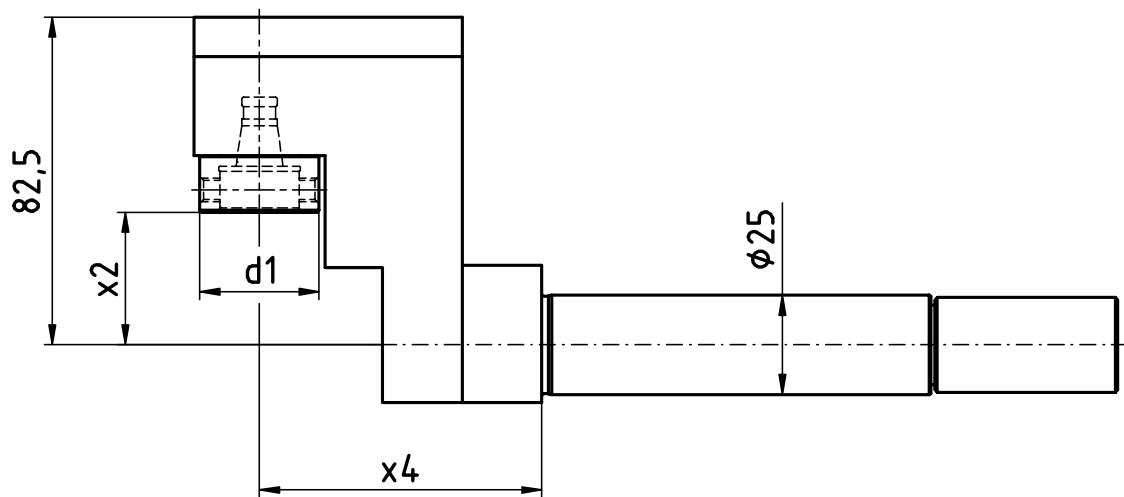
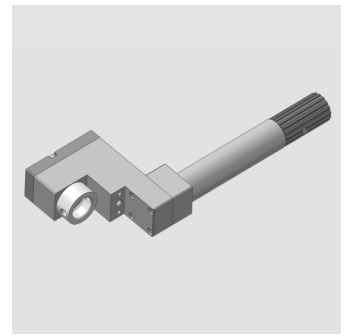

[mm]	[mm]	[mm]	Spindle Broche	[Nm]	[rpm]		Outside cooling Lubrificat. ext.	Internal cooling Lubrificat. cent.	[bar]	Order no. N° de Code
d1	x2	x4	Spindel	T max	n max	i	Aussenkühlung	Innenkühlung	p	Bestellnummer
16	31,3	71	WFB 20-12	6	12.000	1:1				MPU.TO.0210.DE10

Passend für Maschine:	DECO 10
suitable machines:	EvoDECO 10/10
approprié pour la machine:	EvoDECO 10/8

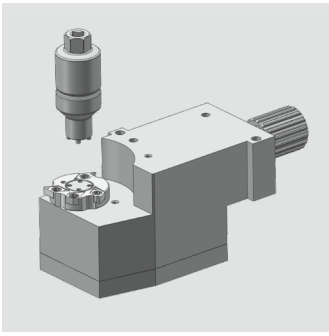

Tornos - EvoDECO

Radial-Bohr- und Fräskopf (Mehrkantschlagen)

radial drilling and milling head (polyhedral beat)

Outil Rotatif Radial de Pertage et de Fraisage (battement polyedrique)

WG 35

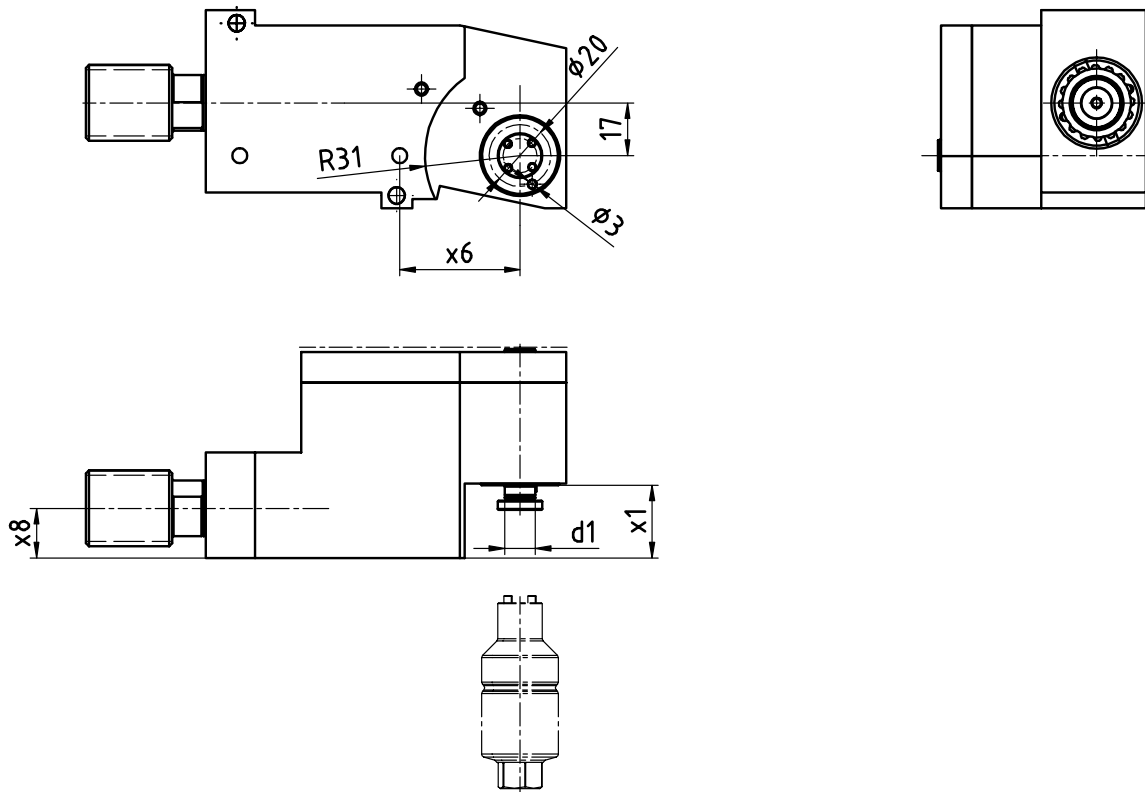

[mm]	[mm]	[mm]	[mm]	Spindle Broche	[Nm]	[rpm]		Outside cooling Lubrificat. ext.	Internal cooling Lubrificat. cent.	[bar]	Order no. N° de Code
d1	x1	x6	x8	Spindel	T max	n max	i	Aussenkühlung	Innenkühlung	p	Bestellnummer
10	23,5	39	16		8	12.000	1:1,333				MPU.TO.0900.DE10

Passend für Maschine:	DECO 10
suitable machines:	EvoDECO 10/10
approprié pour la machine:	EvoDECO 10/8

Tornos - EvoDECO

Bohr- und Fräskopf winkelverstellbar
 Drilling and milling swivel head
 Outil de perçage et de fraisage tournant

WG 35

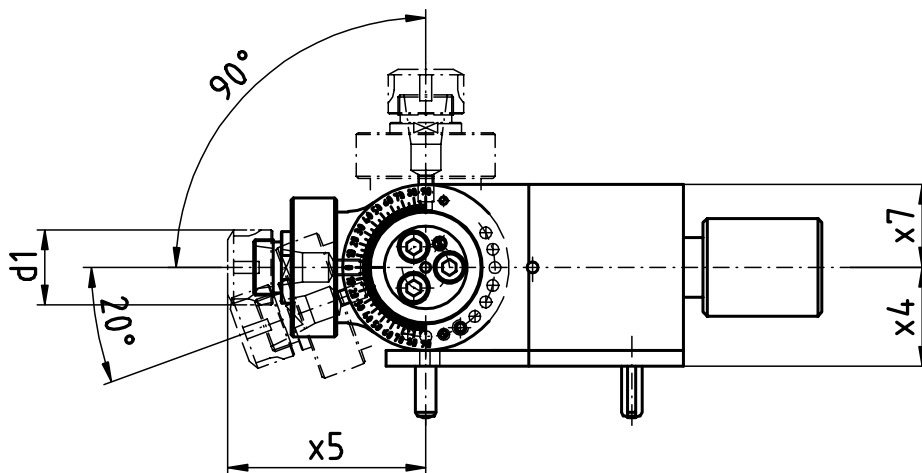
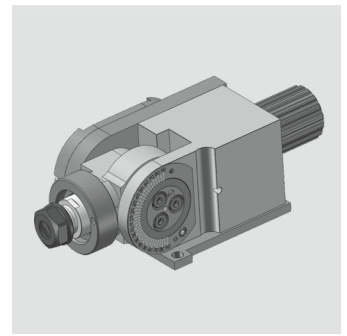

[mm]	[mm]	[mm]	[mm]	Spindle Broche	[Nm]	[rpm]		Outside cooling Lubrificat. ext.	Internal cooling Lubrificat. cent.	[bar]	Order no. N° de Code
d1	x4	x5	x7	Spindel	T max	n max	i	Aussenkühlung	Innenkühlung	p	Bestellnummer
19	25	50	21	ER11	6	12.000	1:1				MPU.TO.0300.DE10

Passend für Maschine:	DECO 10
suitable machines:	EvoDECO 10/10
approprié pour la machine:	EvoDECO 10/8



Tornos - EvoDECO

Bohr- und Fräskopf winkelverstellbar
 Drilling and milling swivel head
 Outil de perçage et de fraisage tournant

WG 35

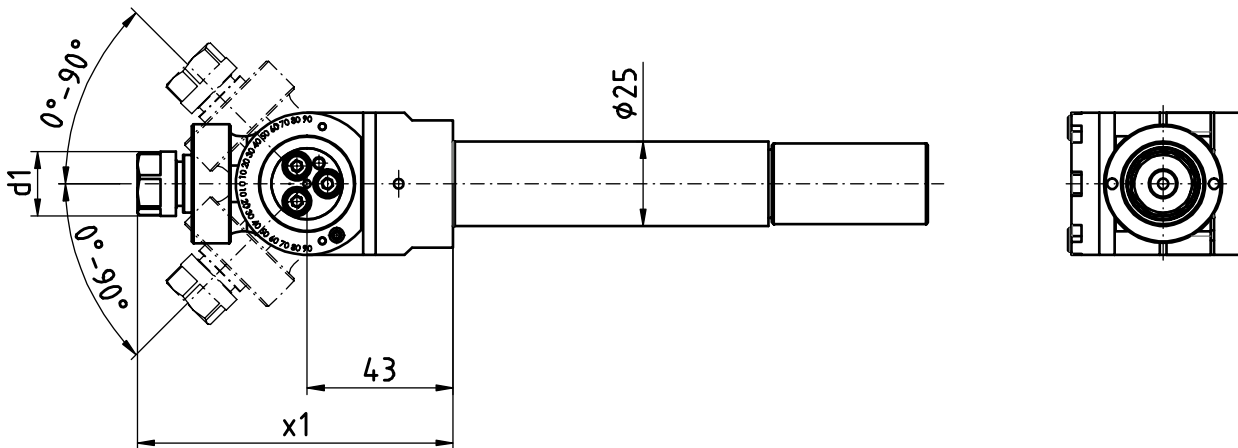

[mm]	[mm]	Spindle	[Nm]	[rpm]		Outside cooling	Internal cooling	[bar]	Order no.
d1	x1	Broche	T max	n max	i	Lubrificat. ext.	Lubrificat. cent.	p	N° de Code
		Spindel				Aussenkühlung	Innenkühlung		Bestellnummer
19	93	ER11	6	12.000	1:1				MPU.TO.0310.DE10

Passend für Maschine:	DECO 10
suitable machines:	EvoDECO 10/10
approprié pour la machine:	EvoDECO 10/8

Tornos - EvoDECO

Gewindewirbelapparat
Thread whirling unit
Unité de tourbillonnement

WG 35

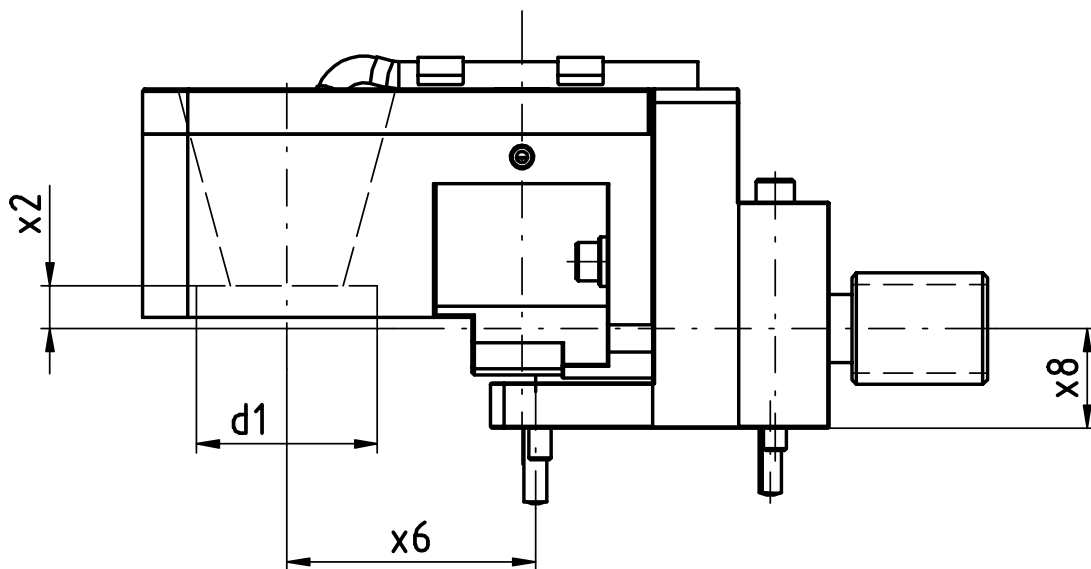
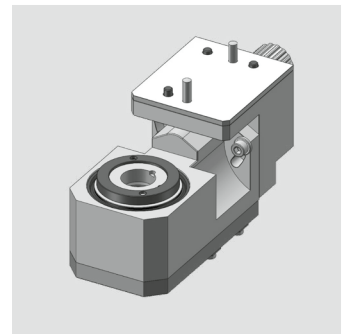

[mm]	[mm]	[mm]	[mm]	Spindle Broche	[Nm]	[rpm]		Outside cooling Lubrificat. ext.	Internal cooling Lubrificat. cent.	[bar]	Order no. N° de Code
d1	x2	x6	x8	Spindel	T max	n max	i	Aussenkühlung	Innenkühlung	p	Bestellnummer
40	9,5	55	22	Tornos org.	6	12.000	1:1	x			MPU.TO.0800.DE10

Passend für Maschine: DECO 10
sutable machines: EvoDECO 10/10
approprié pour la machine: EvoDECO 10/8

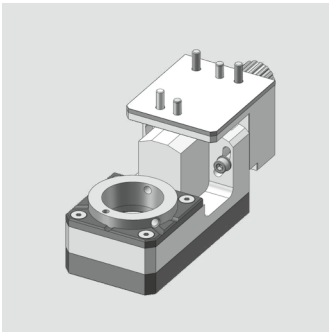

Tornos - EvoDECO

Gewindewirbelapparat modular
 Thread whirling unit
 Unité de tourbillonnement

WG 35

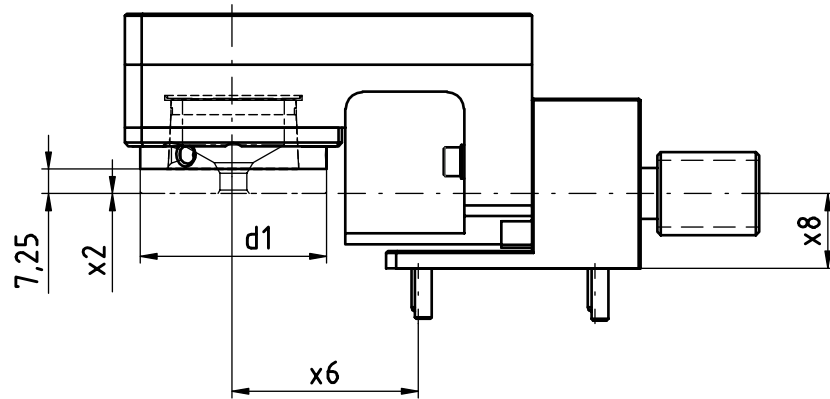
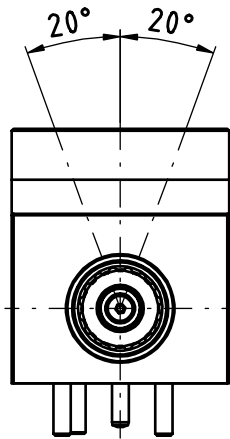

[mm]	[mm]	[mm]	[mm]	Spindle Broche	[Nm]	[rpm]		Outside cooling Lubrificat. ext.	Internal cooling Lubrificat. cent.	[bar]	Order no. N° de Code
d1	x2	x6	x8	Spindel	T max	n max	i	Aussenkühlung	Innenkühlung	p	Bestellnummer
54	0	55	22	WFW 50	6	12.000	1:1	x			MPU.TO.M0800.DE10

Passend für Maschine:	DECO 10
suitable machines:	EvoDECO 10/10
approprié pour la machine:	EvoDECO 10/8

Tornos - EvoDECO

Axial Bohr- und Fräskopf

Axial drilling and milling head

Outil de perçage et de fraisage axiale

WG 35

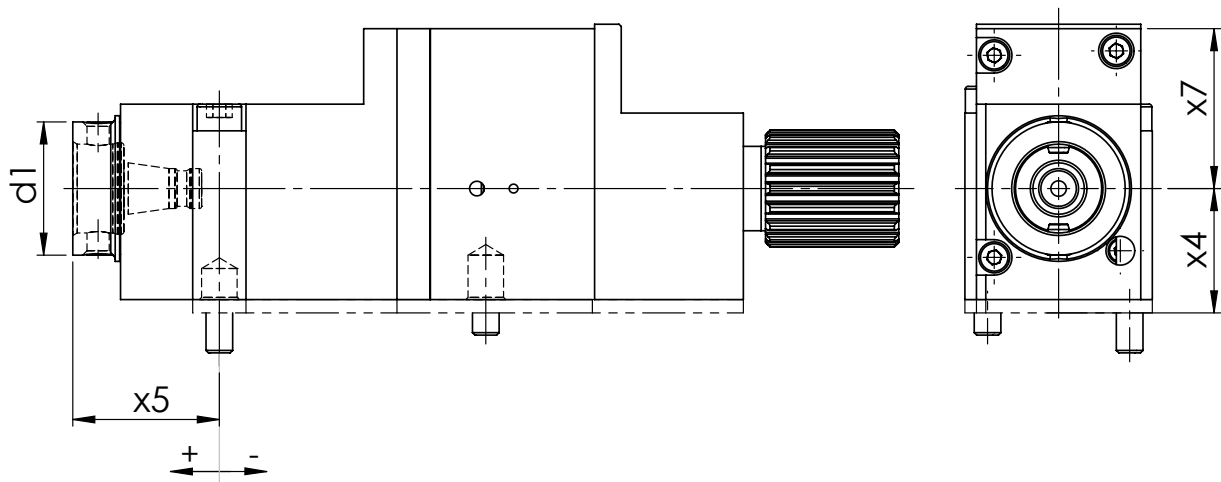
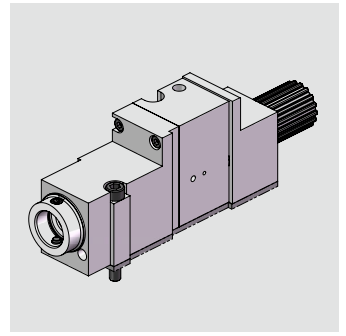

[mm]	[mm]	[mm]	[mm]	Spindle Broche	[Nm]	[rpm]		Outside cooling Lubrificat. ext.	Internal cooling Lubrificat. cent.	[bar]	Order no. N° de Code
d1	x4	x5	x7	Spindel	T max	n max	i	Aussenkühlung	Innenkühlung	p	Bestellnummer
30	28	-7	19	WFB 20-12	8	8.000	1:1				MPU.TO.0100.DE13
30	28	17	19	WFB 20-12	8	8.000	1:1				MPU.TO.0110.DE13
30	28	33	19	WFB 20-12	8	8.000	1:1				MPU.TO.0120.DE13
30	28	17	36	WFB 20-12	3	24.000	1:3				MPU.TO.0130.DE13
30	28	-7	36	WFB 20-12	3	24.000	1:3		x	80	MPU.TO.0100.DE13H
30	28	17	36	WFB 20-12	3	24.000	1:3		x	80	MPU.TO.0110.DE13H
30	28	33	36	WFB 20-12	3	24.000	1:3		x	80	MPU.TO.0120.DE13H
30	28	-7	36	WFB 20-12	8	8.000	1:1		x	80	MPU.TO.0100.DE13H1
30	28	33	36	WFB 20-12	8	8.000	1:1		x	80	MPU.TO.0120.DE13H1

Passend für Maschine: DECO 13 EvoDECO 16/10
 suitable machines: DECO 16 EvoDECO 16/8
 approprié pour la machine:

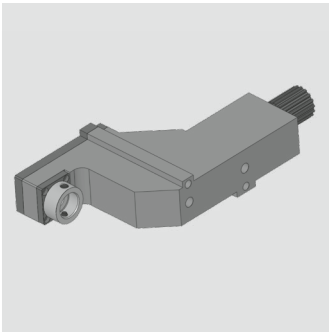

Tornos - EvoDECO

Radial Bohr- und Fräskopf
 Radial drilling and milling head
 Outil de perçage et de fraisage radiale

WG 35

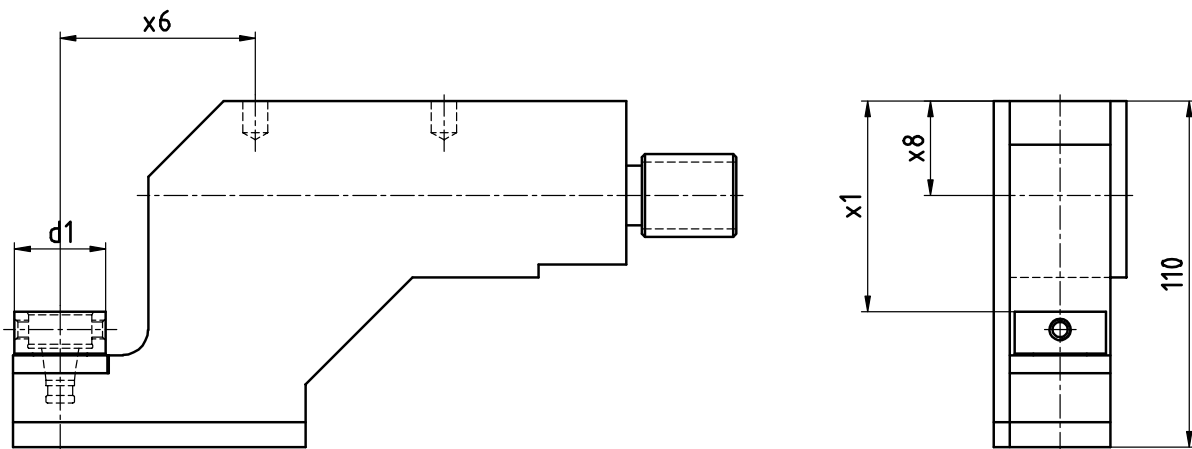

[mm]	[mm]	[mm]	[mm]	Spindle Broche	[Nm]	[rpm]		Outside cooling Lubrificat. ext.	Internal cooling Lubrificat. cent.	[bar]	Order no. N° de Code
d1	x1	x6	x8	Spindel	T max	n max	i	Aussenkühlung	Innenkühlung	p	Bestellnummer
30	67	62	30	WFB 20-12	8	8.000	1:1				MPU.TO.0200.DE13

Passend für Maschine:	DECO 13	EvoDECO 16/10
suitable machines:	DECO 16	EvoDECO 16/8
approprié pour la machine:		

Tornos - EvoDECO

Axial Bohr- und Fräskopf

Axial drilling and milling head

Outil de perçage et de fraisage axiale

WG 35

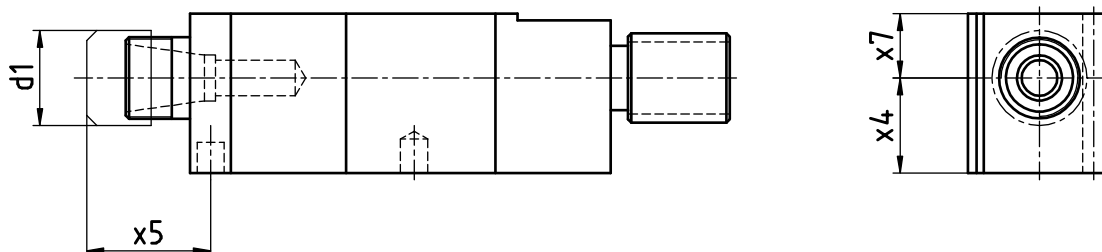
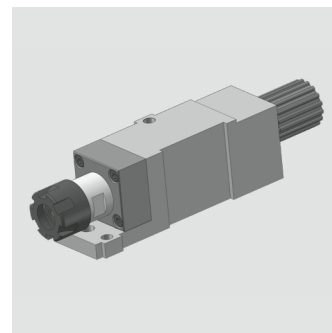

[mm]	[mm]	[mm]	[mm]	Spindle Broche	[Nm]	[rpm]		Outside cooling Lubrificat. ext.	Internal cooling Lubrificat. cent.	[bar]	Order no. N° de Code
d1	x4	x5	x7	Spindel	T max	n max	i	Aussenkühlung	Innenkühlung	p	Bestellnummer
28	28	26,5	19	ER20 MINI	8	8.000	1:1				MPU.TO.0100.DE13.ER20M
28	28	36,5	19	ER20 MINI	8	8.000	1:1				MPU.TO.0110.DE13.ER20M
28	28	71,5	19	ER20 MINI	8	8.000	1:1				MPU.TO.0120.DE13.ER20M

Passend für Maschine:	DECO 13	EvoDECO 16/10
suitable machines:	DECO 16	EvoDECO 16/8
approprié pour la machine:		

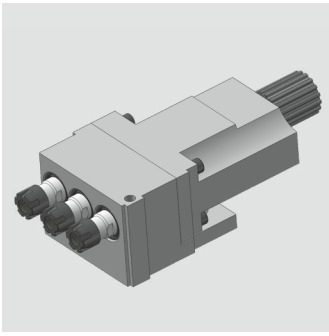

Tornos - EvoDECO

Axial Bohr- und Fräskopf
 Axial drilling and milling head
 Outil de perçage et de fraisage axiale

WG 35

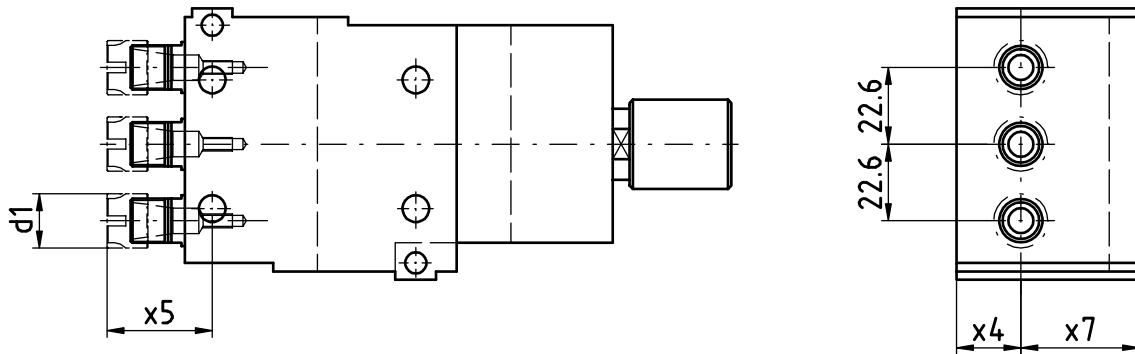

[mm]	[mm]	[mm]	[mm]	Spindle Broche	[Nm]	[rpm]		Outside cooling Lubrificat. ext.	Internal cooling Lubrificat. cent.	[bar]	Order no. N° de Code
d1	x4	x5	x7	Spindel	T max	n max	i	Aussenkühlung	Innenkühlung	p	Bestellnummer
16	19	31	35	ER11 MINI	8	8.000	1:1				MPU.TO.1103.DE13

Passend für Maschine:	DECO 13	EvoDECO 16/10
suitable machines:	DECO 16	EvoDECO 16/8
approprié pour la machine:		

Tornos - EvoDECO

Radial Bohr- und Fräskopf

Radial drilling and milling head

Outil de perçage et de fraisage radiale

WG 35

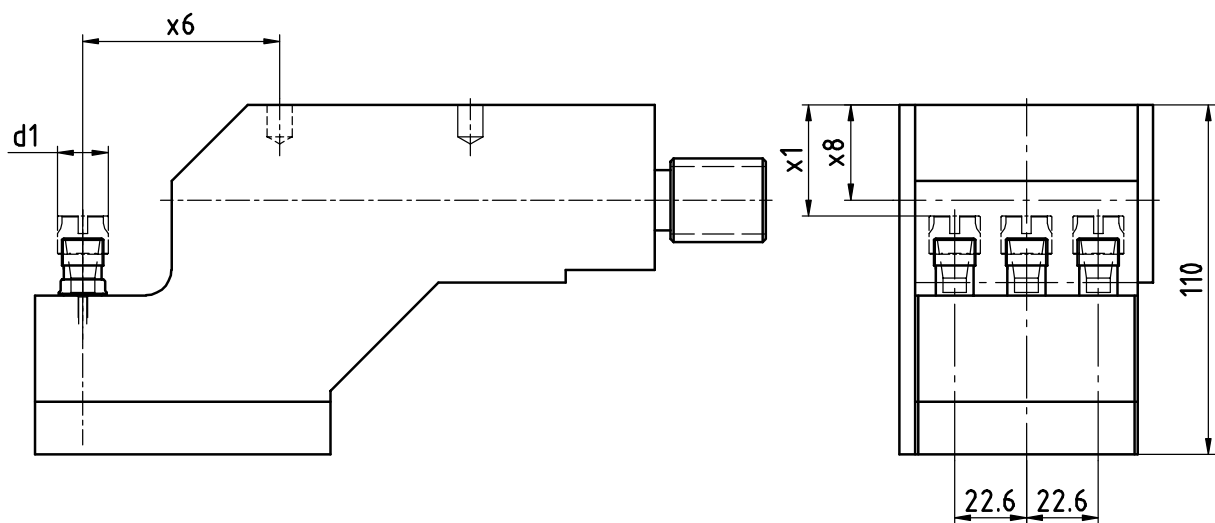
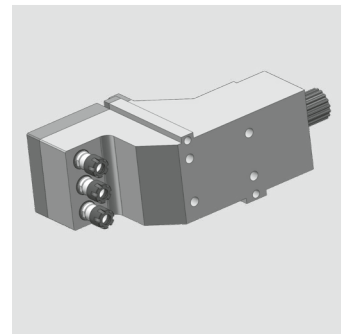

[mm]	[mm]	[mm]	[mm]	Spindle Broche	[Nm]	[rpm]		Outside cooling Lubrificat. ext.	Internal cooling Lubrificat. cent.	[bar]	Order no. N° de Code
d1	x1	x6	x8	Spindel	T max	n max	i	Aussenkühlung	Innenkühlung	p	Bestellnummer
16	35	62	80	ER11 MINI	8	8.000	1:1				MPU.TO.2103.DE13

Passend für Maschine:	DECO 13	EvoDECO 16/10
suitable machines:	DECO 16	EvoDECO 16/8
approprié pour la machine:		

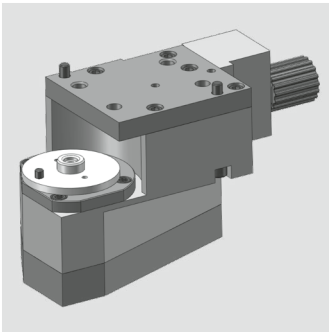

Tornos - EvoDECO

Radial-Bohr- und Fräskopf (Mehrkantschlagen)

radial drilling and milling head (polyhedral beat)

Outil Rotatif Radial de Pertage et de Fraisage (battement polyedrique)

WG 35

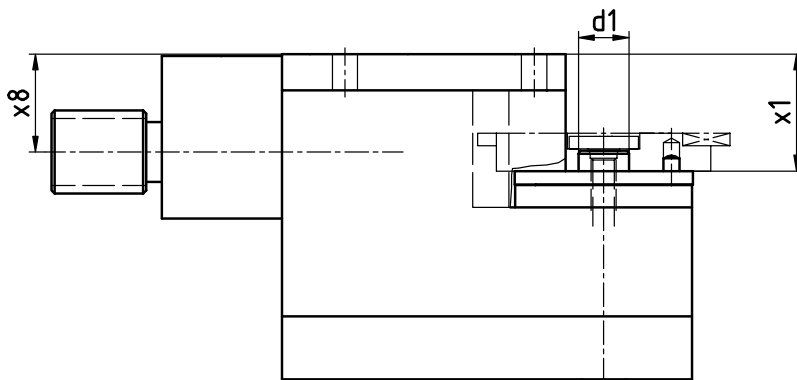
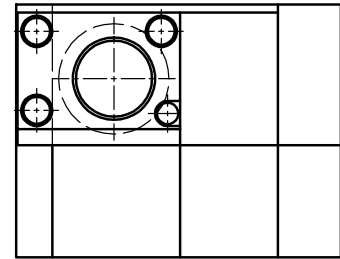
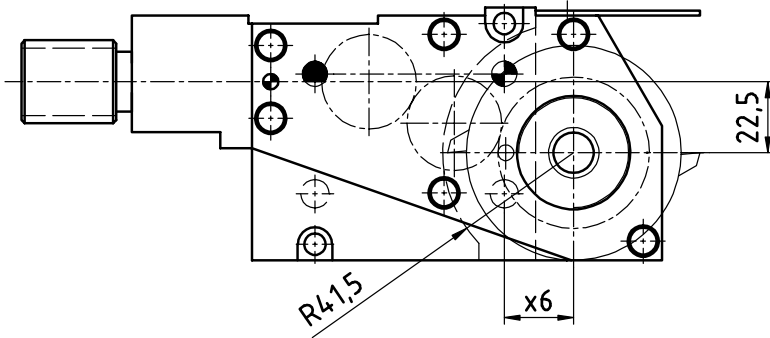

[mm]	[mm]	[mm]	[mm]	Spindle Broche	[Nm]	[rpm]		Outside cooling Lubrificat. ext.	Internal cooling Lubrificat. cent.	[bar]	Order no. N° de Code
d1	x1	x6	x8	Spindel	T max	n max	i	Aussenkühlung	Innenkühlung	p	Bestellnummer
16	37	22	31		16	5.000	1,6:1				MPU.T0.0900.DE13

Passend für Maschine:	DECO 13	EvoDECO 16/10
suitable machines:	DECO 16	EvoDECO 16/8
approprié pour la machine:		

Tornos - EvoDECO

Bohr- und Fräskopf winkelverstellbar
 Drilling and milling swivel head
 Outil de perçage et de fraisage tournant

WG 35

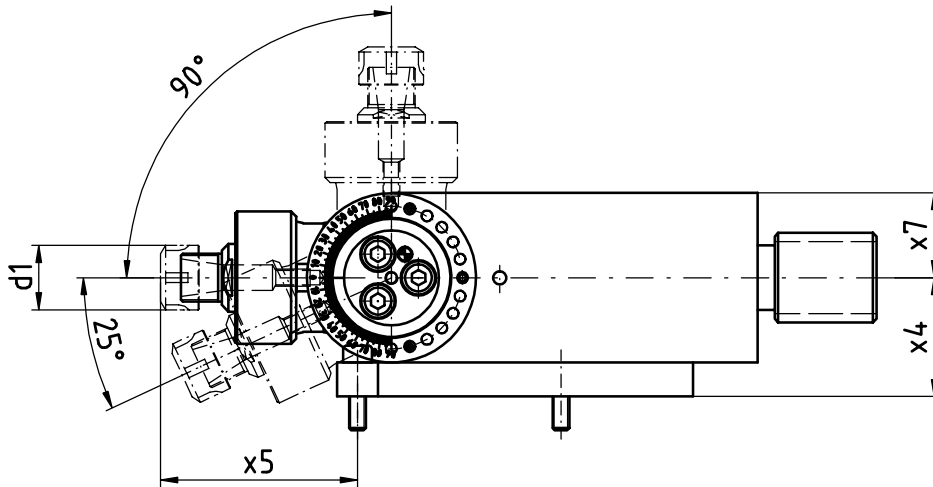
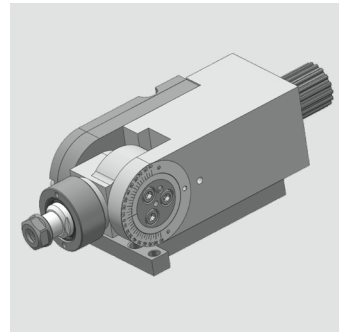

[mm]	[mm]	[mm]	[mm]	Spindle Broche	[Nm]	[rpm]		Outside cooling Lubrificat. ext.	Internal cooling Lubrificat. cent.	[bar]	Order no. N° de Code
d1	x4	x5	x7	Spindel	T max	n max	i	Aussenkühlung	Innenkühlung	p	Bestellnummer
19	35	58	25	ER11	8	8.000	1:1				MPU.TO.0300.DE13

Passend für Maschine: DECO 13 EvoDECO 16/10
 suitable machines: DECO 16 EvoDECO 16/8
 approprié pour la machine:

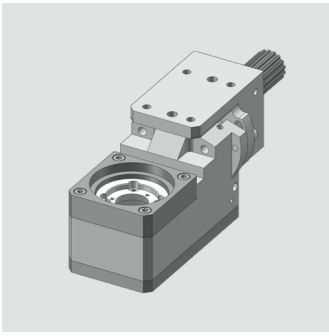

Tornos - EvoDECO

Gewindewirbelapparat
Thread whirling unit
Unité de tourbillonnement

WG 35

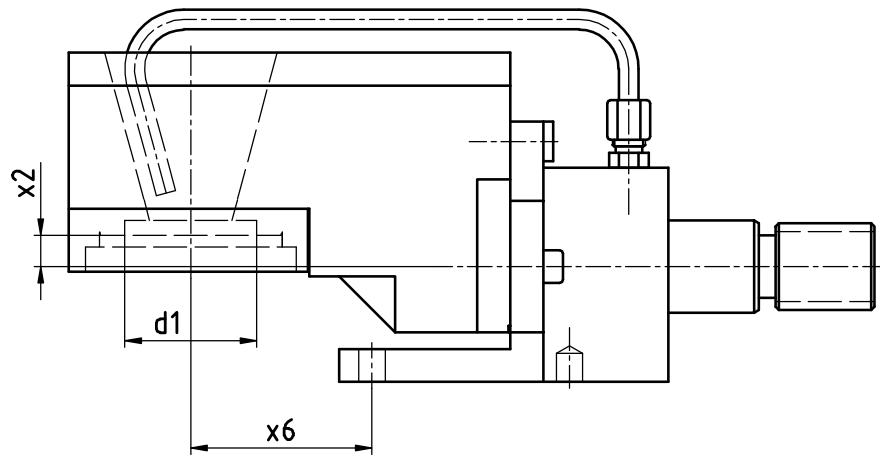
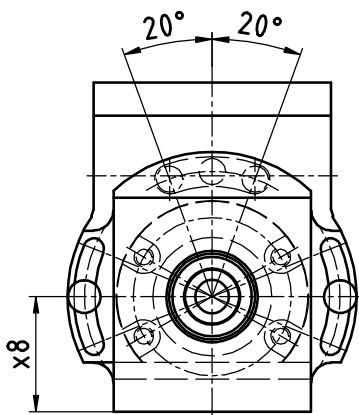

[mm]	[mm]	[mm]	[mm]	Spindle Broche	[Nm]	[rpm]		Outside cooling Lubrificat. ext.	Internal cooling Lubrificat. cent.	[bar]	Order no. N° de Code
d1	x2	x6	x8	Spindel	T max	n max	i	Aussenkühlung	Innenkühlung	p	Bestellnummer
40	9,5	55	35	Tornos org.	16	8.000	1:1	x			MPU.TO.0800.DE13

Passend für Maschine:	DECO 13	EvoDECO 16/10
suitable machines:	DECO 16	EvoDECO 16/8
approprié pour la machine:		

Tornos - EvoDECO

Gewindewirbelapparat modular
 Thread whirling unit
 Unité de tourbillonnement

WG 35

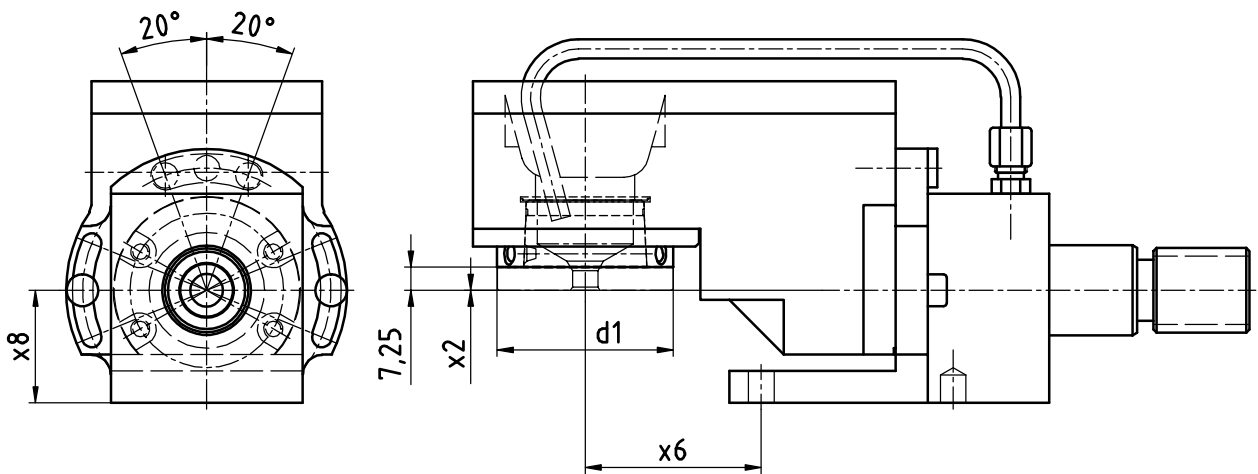
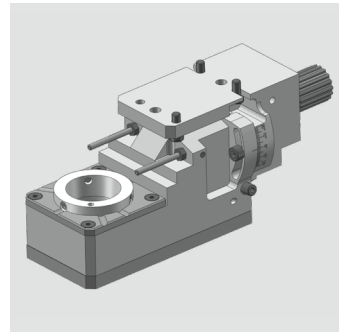

[mm]	[mm]	[mm]	[mm]	Spindle Broche	[Nm]	[rpm]		Outside cooling Lubrificat. ext.	Internal cooling Lubrificat. cent.	[bar]	Order no. N° de Code
d1	x2	x6	x8	Spindel	T max	n max	i	Aussenkühlung	Innenkühlung	p	Bestellnummer
54	0	55	35	WFW 50	16	8.000	1:1	x			MPU.TO.M0800.DE13

Passend für Maschine: DECO 13 EvoDECO 16/10
 suitable machines: DECO 16 EvoDECO 16/8
 approprié pour la machine:

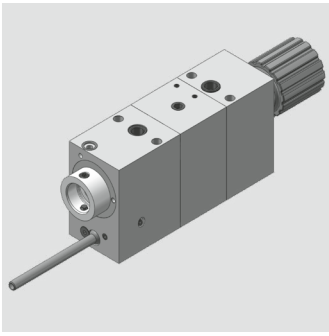

Tornos - EvoDECO

Axial Bohr- und Fräskopf
 Axial drilling and milling head
 Outil de perçage et de fraisage axiale

WG 35

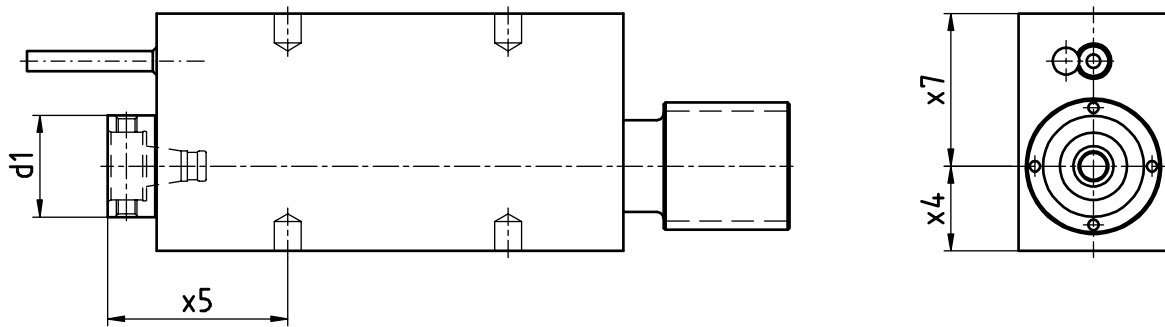

[mm]	[mm]	[mm]	[mm]	Spindle Broche	[Nm]	[rpm]		Outside cooling Lubrificat. ext.	Internal cooling Lubrificat. cent.	[bar]	Order no. N° de Code
d1	x4	x5	x7	Spindel	T max	n max	i	Aussenkühlung	Innenkühlung	p	Bestellnummer
30	25	53	45	WFB 20-12	16	8.000	1:1	x			MPU.TO.0100.DE20-H25
30	25	53	45	WFB 20-12	16	8.000	1:1	x	x	170	MPU.TO.0100.DE20H1
30	25	53	45	WFB 20-12	8	14.544	1:1,818	x	x	170	MPU.TO.0100.DE20H2
30	27	53	43	WFB 20-12	16	8.000	1:1	x			MPU.TO.0100.DE20-H27
30	25	80	45	WFB 20-12	16	8.000	1:1	x			MPU.TO.0110.DE20
30	25	80	45	WFB 20-12	16	8.000	1:1	x	x	170	MPU.TO.0110.DE20H1
30	25	80	45	WFB 20-12	8	14.544	1:1,818	x	x	170	MPU.TO.0110.DE20H2
30	25	114	45	WFB 20-12	16	8.000	1:1	x			MPU.TO.0120.DE20
30	25	114	45	WFB 20-12	8	14.544	1:1,818	x	x	170	MPU.TO.0120.DE20H2

Passend für Maschine: DECO 20 EvoDECO 20
 suitable machines: DECO 26 EvoDECO 32
 approprié pour la machine:

Tornos - EvoDECO

Radial Bohr- und Fräskopf

Radial drilling and milling head

Outil de perçage et de fraisage radiale

WG 35

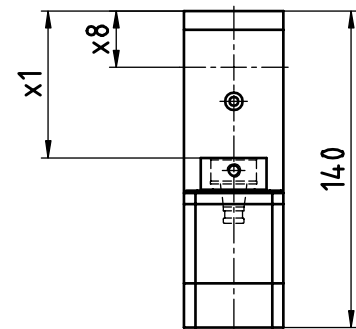
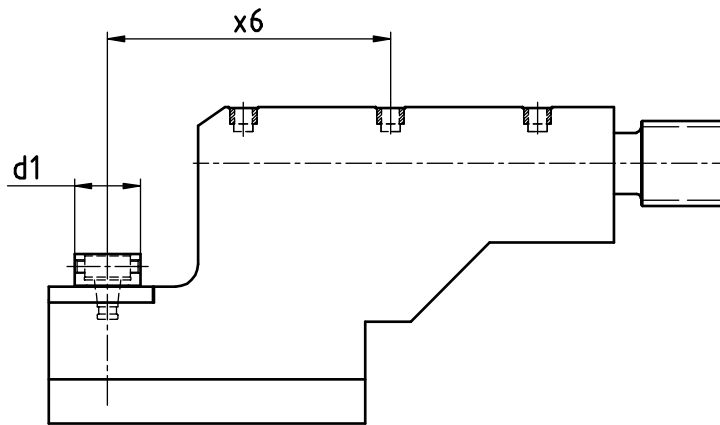
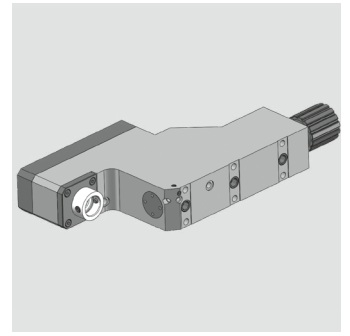

[mm]	[mm]	[mm]	[mm]	Spindle Broche	[Nm]	[rpm]		Outside cooling Lubrificat. ext.	Internal cooling Lubrificat. cent.	[bar]	Order no. N° de Code
d1	x1	x6	x8	Spindel	T max	n max	i	Aussenkühlung	Innenkühlung	p	Bestellnummer
30	65	125	25	WFB 20-12	8	8.000	1:1	x			MPU.TO.0200.DE20

Passend für Maschine:	DECO 20	EvoDECO 20
suitable machines:	DECO 26	EvoDECO 32
approprié pour la machine:		

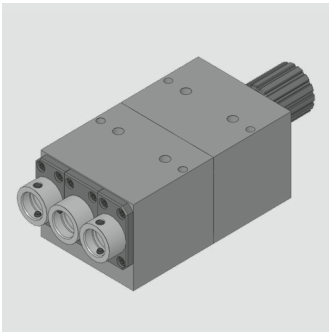

Tornos - EvoDECO

Axial Bohr- und Fräskopf
 Axial drilling and milling head
 Outil de perçage et de fraisage axiale

WG 35

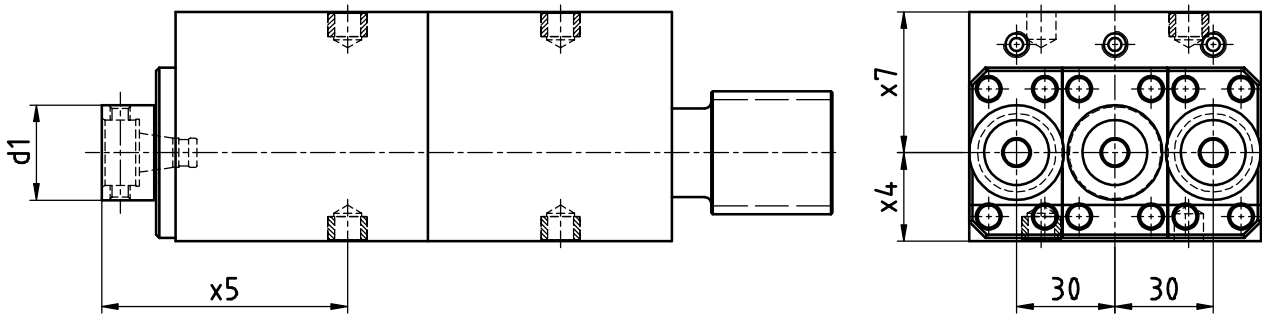

[mm]	[mm]	[mm]	[mm]	Spindle Broche	[Nm]	[rpm]		Outside cooling Lubrificat. ext.	Internal cooling Lubrificat. cent.	[bar]	Order no. N° de Code
d1	x4	x5	x7	Spindel	T max	n max	i	Aussenkühlung	Innenkühlung	p	Bestellnummer
30	23	75	47	WFB 20-12	8	8.000	1:1	x			MPU.TO.1103.DE20

Passend für Maschine:	DECO 20	EvoDECO 20
suitable machines:	DECO 26	EvoDECO 32
approprié pour la machine:		

Tornos - EvoDECO

Radial Bohr- und Fräskopf

Radial drilling and milling head

Outil de perçage et de fraisage radiale

WG 35

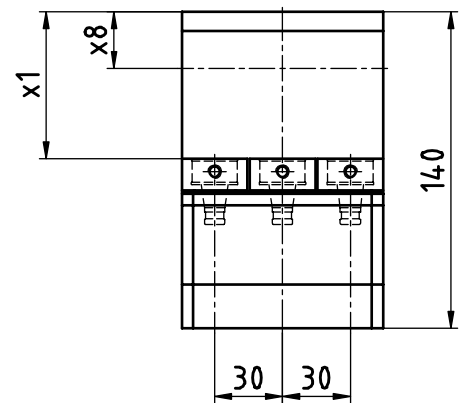
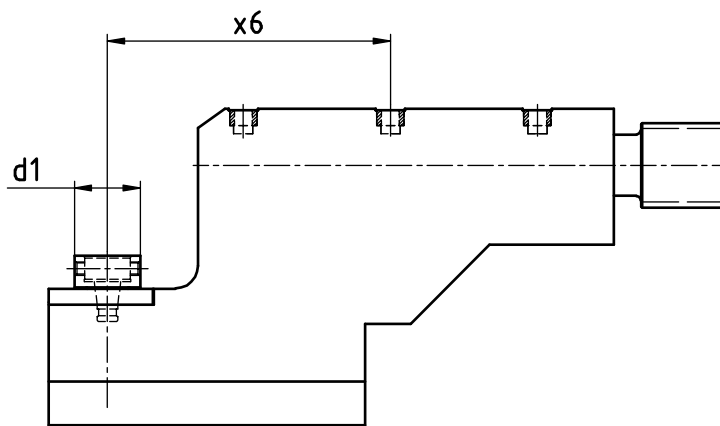
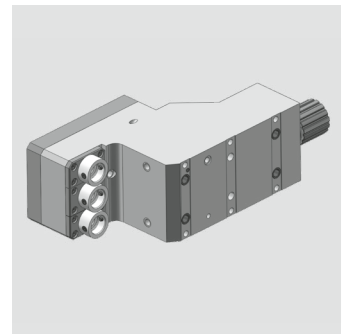

[mm]	[mm]	[mm]	[mm]	Spindle Broche	[Nm]	[rpm]		Outside cooling Lubrificat. ext.	Internal cooling Lubrificat. cent.	[bar]	Order no. N° de Code
d1	x1	x6	x8	Spindel	T max	n max	i	Aussenkühlung	Innenkühlung	p	Bestellnummer
29	23	125	25	WFB 20-12	8	8.000	1:1	x			MPU.TO.2103.DE20

Passend für Maschine:	DECO 20	EvoDECO 20
suitable machines:	DECO 26	EvoDECO 32
approprié pour la machine:		

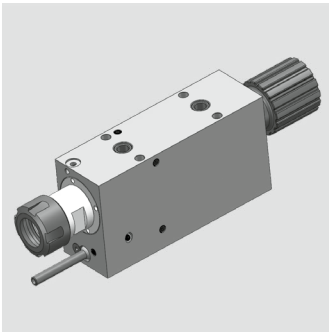

Tornos - EvoDECO

Axial Bohr- und Fräskopf
 Axial drilling and milling head
 Outil de perçage et de fraisage axiale

WG 35

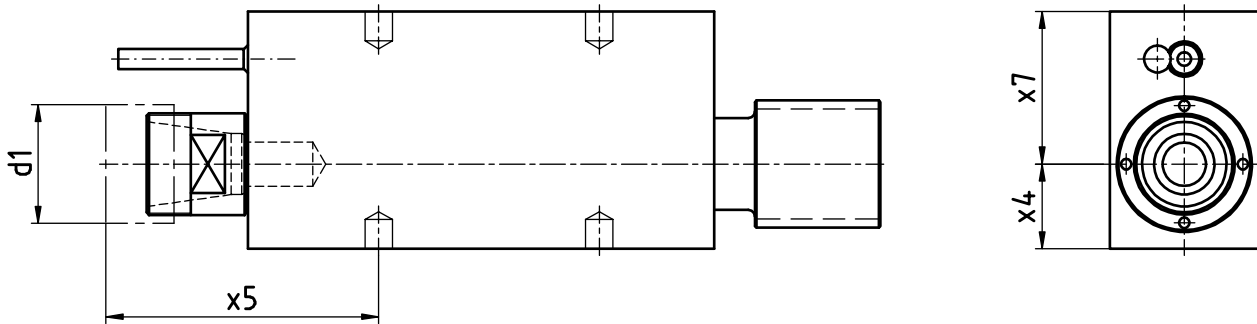

[mm]	[mm]	[mm]	[mm]	Spindle Broche	[Nm]	[rpm]		Outside cooling Lubrificat. ext.	Internal cooling Lubrificat. cent.	[bar]	Order no. N° de Code
d1	x4	x5	x7	Spindel	T max	n max	i	Aussenkühlung	Innenkühlung	p	Bestellnummer
35	25	80	45	ER25 MINI	16	8.000	1:1	x			MPU.TO.0100.DE20.ER25M
35	25	110	45	ER25 MINI	16	8.000	1:1	x			MPU.TO.0110.DE20.ER25M
35	25	145	45	ER25 MINI	16	8.000	1:1	x			MPU.TO.0120.DE20.ER25M

Passend für Maschine:	DECO 20	EvoDECO 20
suitable machines:	DECO 26	EvoDECO 32
approprié pour la machine:		

Tornos - EvoDECO

Radial Bohr- und Fräskopf

Radial drilling and milling head

Outil de perçage et de fraisage radiale

WG 35

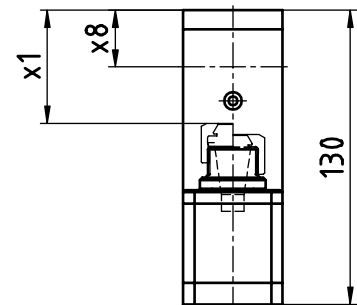
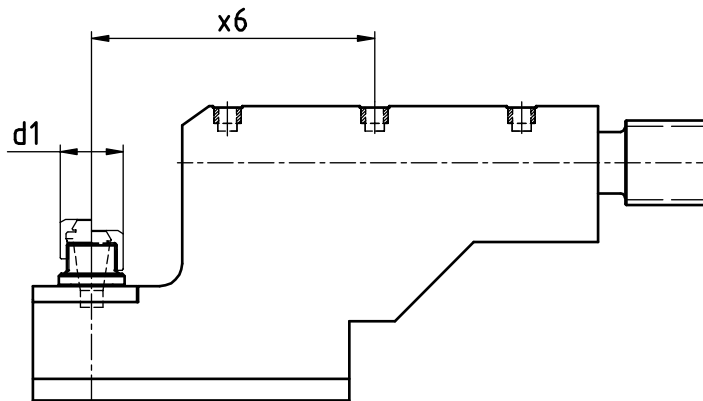
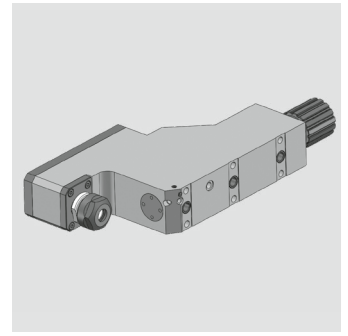

[mm]	[mm]	[mm]	[mm]	Spindle Broche	[Nm]	[rpm]		Outside cooling Lubrificat. ext.	Internal cooling Lubrificat. cent.	[bar]	Order no. N° de Code
d1	x1	x6	x8	Spindel	T max	n max	i	Aussenkühlung	Innenkühlung	p	Bestellnummer
28	50	125	25	ER16	8	8.000	1:1	x			MPU.TO.0210.DE20

Passend für Maschine:	DECO 20	EvoDECO 20
suitable machines:	DECO 26	EvoDECO 32
approprié pour la machine:		

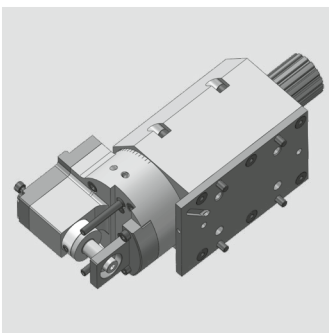

Tornos - EvoDECO

Radial-Bohr- und Fräskopf (Mehrkantschlagen)

radial drilling and milling head (polyhedral beat)

Outil Rotatif Radial de Pertage et de Fraisage (battement polyedrique)

WG 35

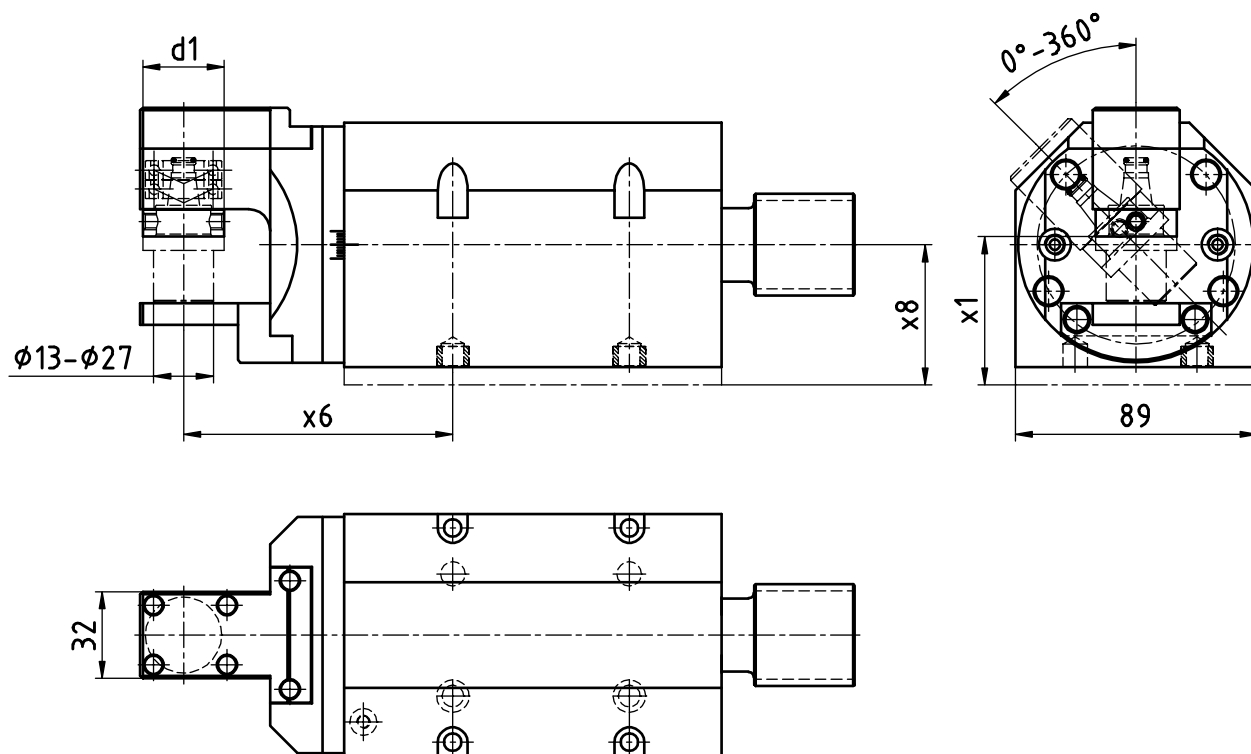

[mm]	[mm]	[mm]	[mm]	Spindle Broche	[Nm]	[rpm]		Outside cooling Lubrificat. ext.	Internal cooling Lubrificat. cent.	[bar]	Order no. N° de Code
d1	x1	x6	x8	Spindel	T max	n max	i	Aussenkühlung	Innenkühlung	p	Bestellnummer
30	54,7	99,25	51,7	WFB 20-12	16	8.000	1:1	x			MPU.TO.0900.DE20

Passend für Maschine:	DECO 20	EvoDECO 20
suitable machines:	DECO 26	EvoDECO 32
approprié pour la machine:		

Achtung! Einsetzbar als schwenbarer Winkelkopf
attention! Useable as angle toolholder adjustable
attention! applicable en tant que tête d angle pivotante

Tornos - EvoDECO

Bohr- und Fräskopf winkelverstellbar
 Drilling and milling swivel head
 Outil de perçage et de fraisage tournant

WG 35

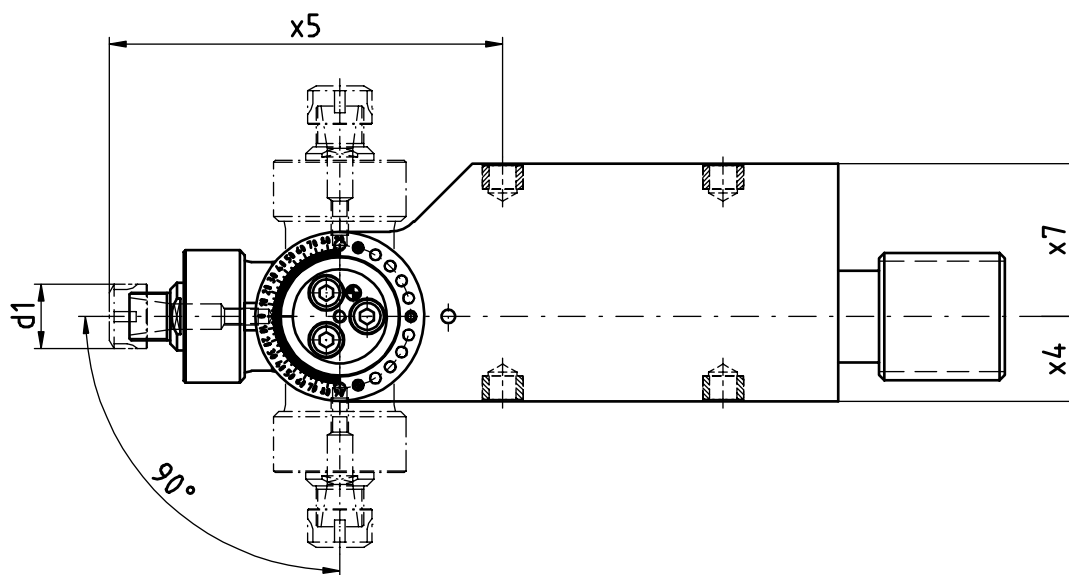
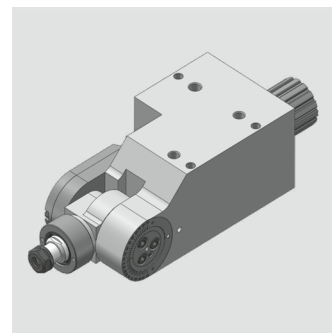

[mm]	[mm]	[mm]	[mm]	Spindle Broche	[Nm]	[rpm]		Outside cooling Lubrificat. ext.	Internal cooling Lubrificat. cent.	[bar]	Order no. N° de Code
d1	x4	x5	x7	Spindel	T max	n max	i	Aussenkühlung	Innenkühlung	p	Bestellnummer
19	25	116	45	ER11	8	8.000	1:1				MPU.TO.0300.DE20
19	25	148	45	ER11	8	8.000	1:1				MPU.TO.0310.DE20

Passend für Maschine: suitable machines: approprié pour la machine:	DECO 20	EvoDECO 20
	DECO 26	EvoDECO 32

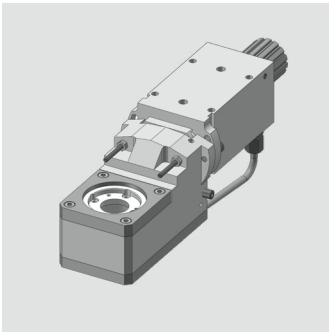

Tornos - EvoDECO

Gewindewirbelapparat
Thread whirling unit
Unité de tourbillonnement

WG 35

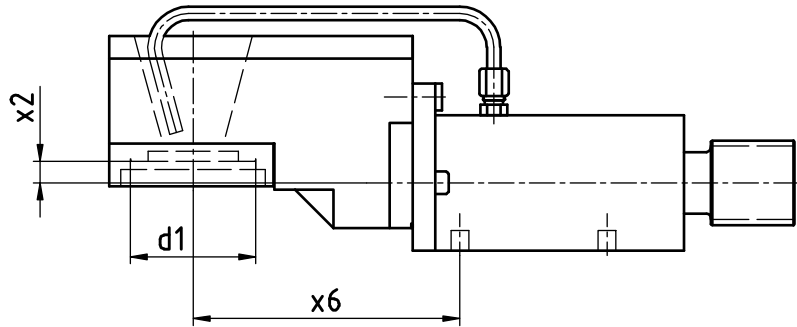
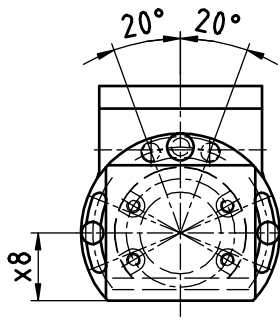

[mm]	[mm]	[mm]	[mm]	Spindle Broche	[Nm]	[rpm]		Outside cooling Lubrificat. ext.	Internal cooling Lubrificat. cent.	[bar]	Order no. N° de Code
d1	x2	x6	x8	Spindel	T max	n max	i	Aussenkühlung	Innenkühlung	p	Bestellnummer
40	9,5	118	35	Tornos org.	16	8.000	1:1	x			MPU.TO.0800.DE20

Passend für Maschine:	DECO 20	EvoDECO 20
suitable machines:	DECO 26	EvoDECO 32
approprié pour la machine:		

Tornos - EvoDECO

Gewindewirbelapparat modular

Thread whirling unit

Unité de tourbillonnement

WG 35

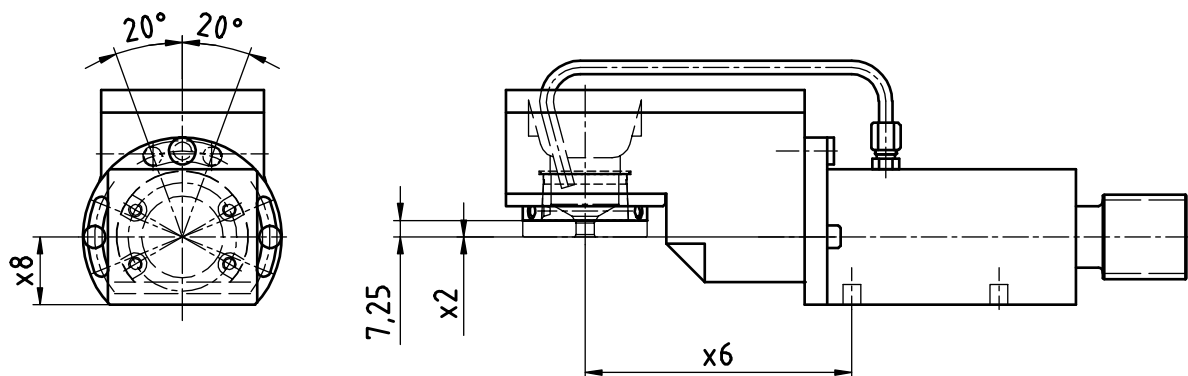
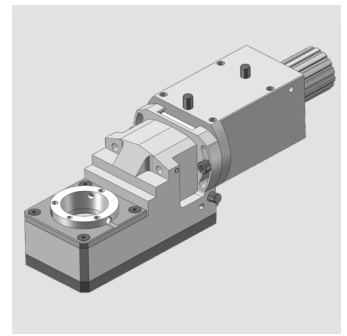

[mm]	[mm]	[mm]	[mm]	Spindle Broche	[Nm]	[rpm]		Outside cooling Lubrificat. ext.	Internal cooling Lubrificat. cent.	[bar]	Order no. N° de Code
d1	x2	x6	x8	Spindel	T max	n max	i	Aussenkühlung	Innenkühlung	p	Bestellnummer
54	0	118	30	WFW 50	16	8.000	1:1	x			MPU.TO.M0800.DE20

Passend für Maschine:	DECO 20	EvoDECO 20
suitable machines:	DECO 26	EvoDECO 32
approprié pour la machine:		

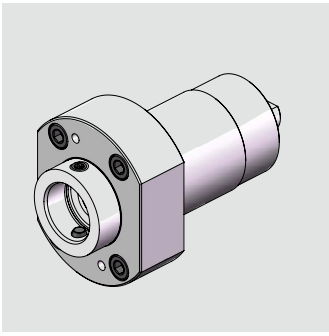

Tornos - Gamma

Axial Bohr- und Fräskopf
 Axial drilling and milling head
 Outil de perçage et de fraisage axiale

WG 35

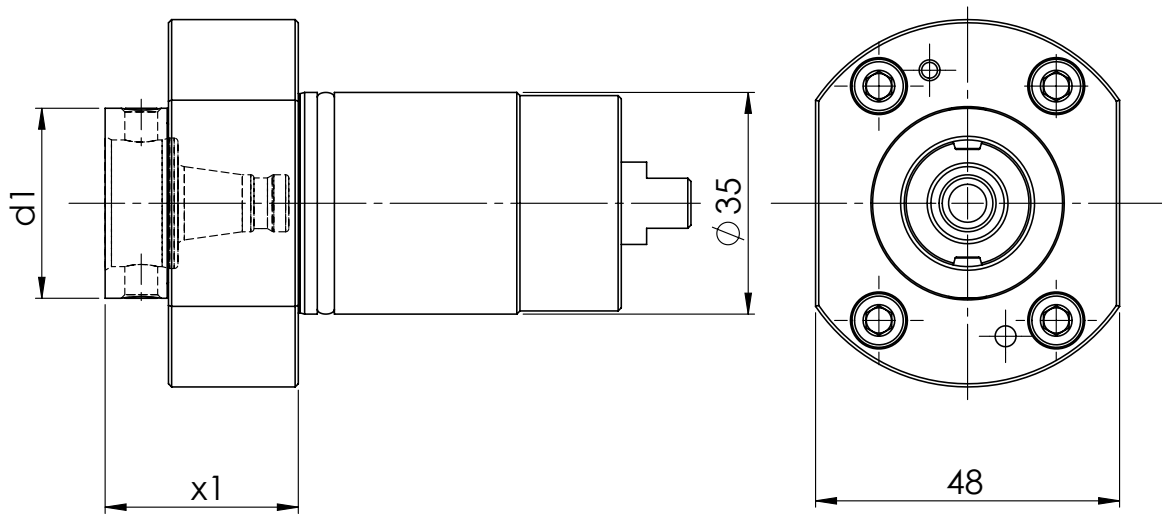

[mm]	[mm]	Spindle Broche Spindel	[Nm] T max	[rpm] n max	i	Outside cooling Lubrificat. ext. Aussenkühlung	Internal cooling Lubrificat. cent. Innenkühlung	[bar] p	Order no. N° de Code Bestellnummer
d1	x1								
30	30,5	WFB 20-12	10	8.000	1:1				MPU.Z35.B20.AA0.GA

Passend für Maschine: Gamma 20
 suitable machines:
 approprié pour la machine:

Tornos - Gamma

Axial Bohr- und Fräskopf

Axial drilling and milling head

Outil de perçage et de fraisage axiale

WG 35

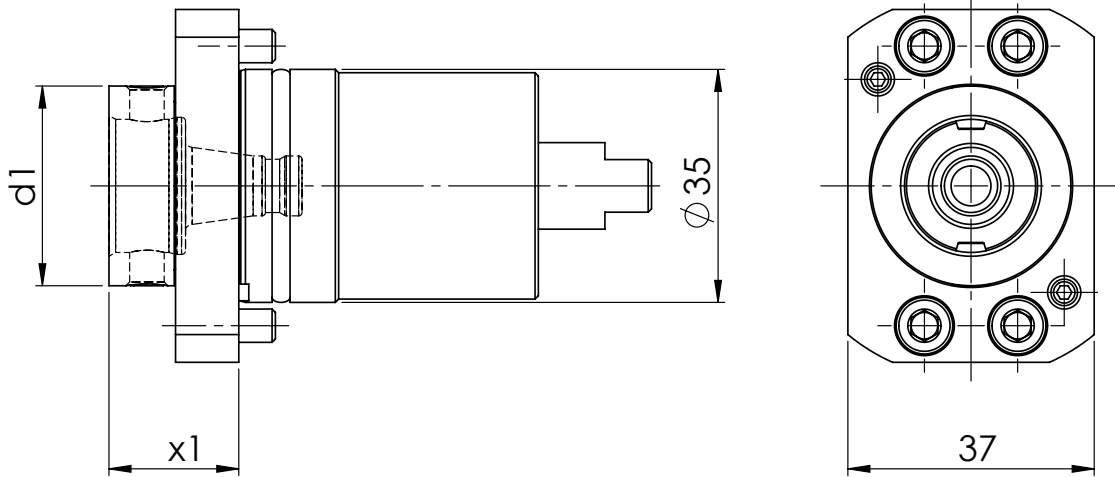
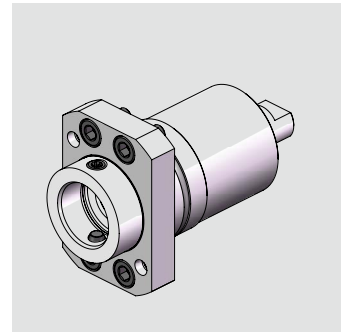

[mm]	[mm]	Spindle Broche	[Nm]	[rpm]		Outside cooling Lubrificat. ext.	Internal cooling Lubrificat. cent.	[bar]	Order no. N° de Code
d1	x1	Spindel	T max	n max	i	Aussenkühlung	Innenkühlung	p	Bestellnummer
30	19,5	WFB 20-12	10	8.000	1:1				MPU.Z35.B20.AA0.GAR

Passend für Maschine: Gamma 20
 suitable machines:
 approprié pour la machine:

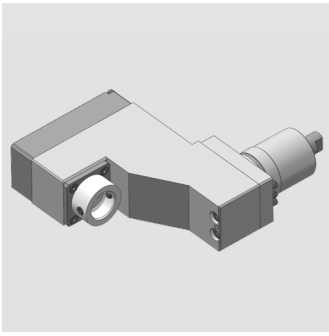

Tornos - Gamma

Radial Bohr- und Fräskopf
 Radial drilling and milling head
 Outil de perçage et de fraisage radiale

WG 35

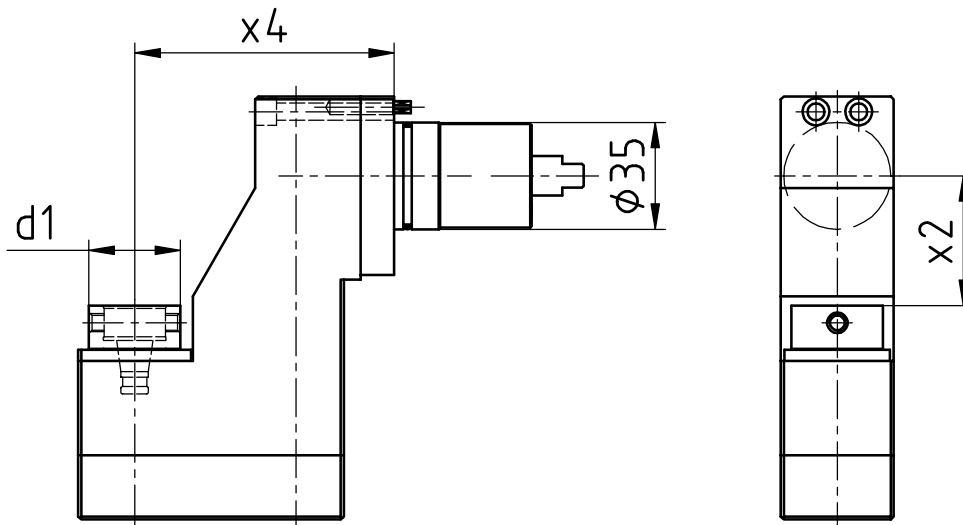

[mm]	[mm]	[mm]	Spindle Broche	[Nm]	[rpm]		Outside cooling Lubrificat. ext.	Internal cooling Lubrificat. cent.	[bar]	Order no. N° de Code
d1	x2	x4	Spindel	T max	n max	i	Aussenkühlung	Innenkühlung	p	Bestellnummer
30	42,5	85	WFB 20-12	10	8.000	1:1				MPU.Z35.B20.RA0.GA

Passend für Maschine: suitable machines: approprié pour la machine:	Gamma 20
--	----------

Tornos - Gamma

Radial Bohr- und Fräskopf

Radial drilling and milling head

Outil de perçage et de fraisage radiale

WG 35

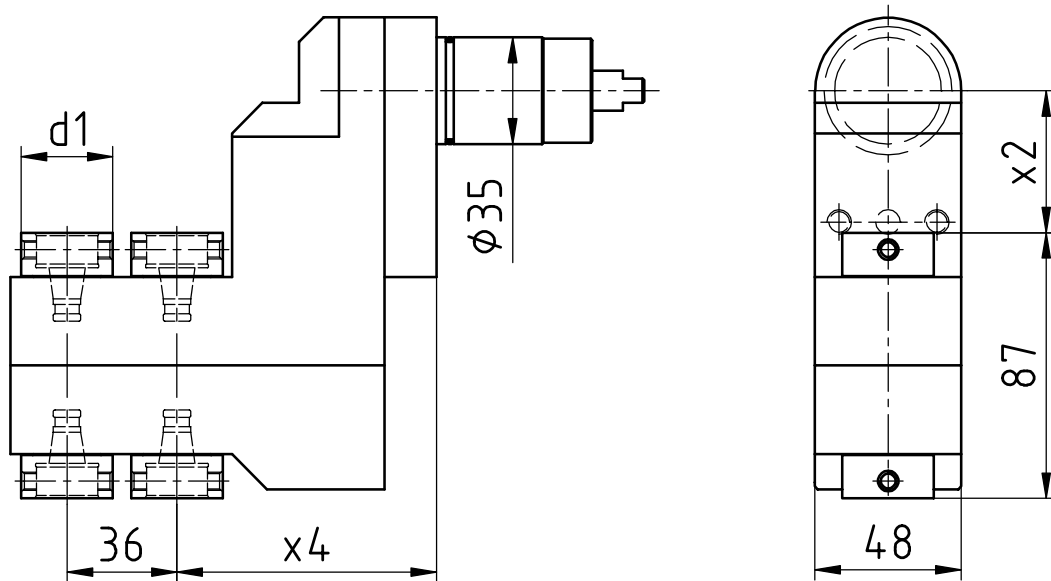
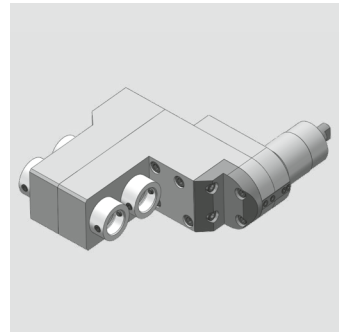

[mm]	[mm]	[mm]	Spindle Broche	[Nm]	[rpm]		Outside cooling Lubrificat. ext.	Internal cooling Lubrificat. cent.	[bar]	Order no. N° de Code
d1	x2	x4	Spindel	T max	n max	i	Aussenkühlung	Innenkühlung	p	Bestellnummer
30	46,5	85	WFB 20-12	3	8.000	1:1				MPU.Z35.B20.4A0.GA

Passend für Maschine:	Gamma 20
suitable machines:	
approprié pour la machine:	

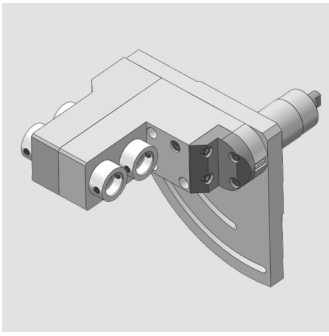

Tornos - Gamma

Radial Bohr- und Fräskopf
 Radial drilling and milling head
 Outil de perçage et de fraisage radiale

WG 35

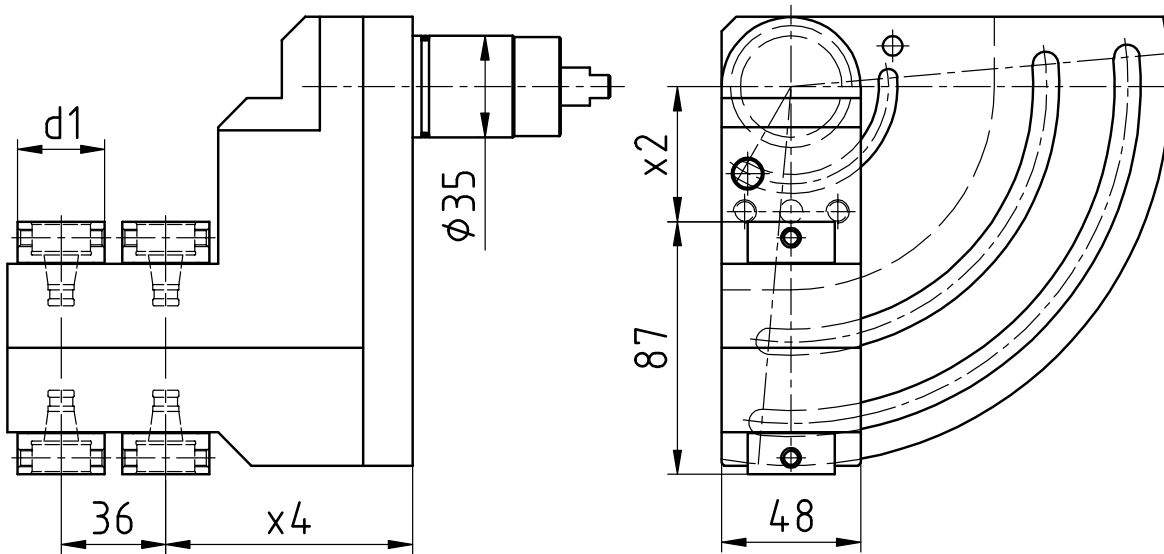

[mm]	[mm]	[mm]	Spindle Broche	[Nm]	[rpm]		Outside cooling Lubrificat. ext.	Internal cooling Lubrificat. cent.	[bar]	Order no. N° de Code
d1	x2	x4	Spindel	T max	n max	i	Aussenkühlung	Innenkühlung	p	Bestellnummer
30	46,5	85	WFB 20-12	3	8.000	1:1				MPU.Z35.B20.4S0.GA

Passend für Maschine: Gamma 20
 suitable machines:
 approprié pour la machine:

Tornos - Gamma

Gewindewirbelapparat
Thread whirling unit
Unité de tourbillonnement

WG 35

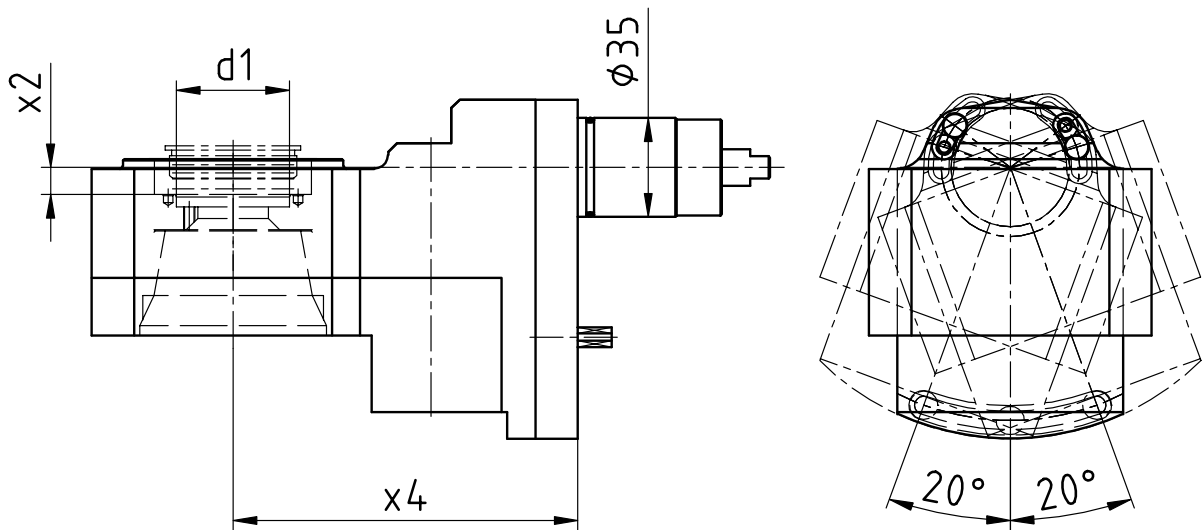
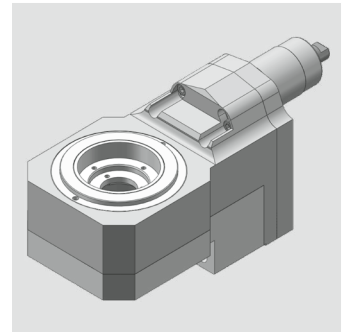

[mm]	[mm]	[mm]	Spindle Broche Spindel	[Nm] T max	[rpm] n max		Outside cooling Lubrificat. ext. Aussenkühlung	Internal cooling Lubrificat. cent. Innenkühlung	[bar] p	Order no. N° de Code Bestellnummer
d1	x2	x4			i					
40	9,5	122	MONO	16	6.932	1,154:1	x			MPU.Z35.0800.GA

Passend für Maschine: Gamma 20
suitable machines:
approprié pour la machine:

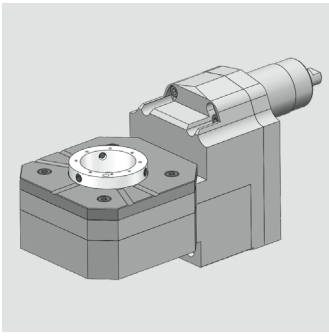

Tornos - Gamma

Gewindewirbelapparat modular
 Thread whirling unit
 Unité de tourbillonnement

WG 35

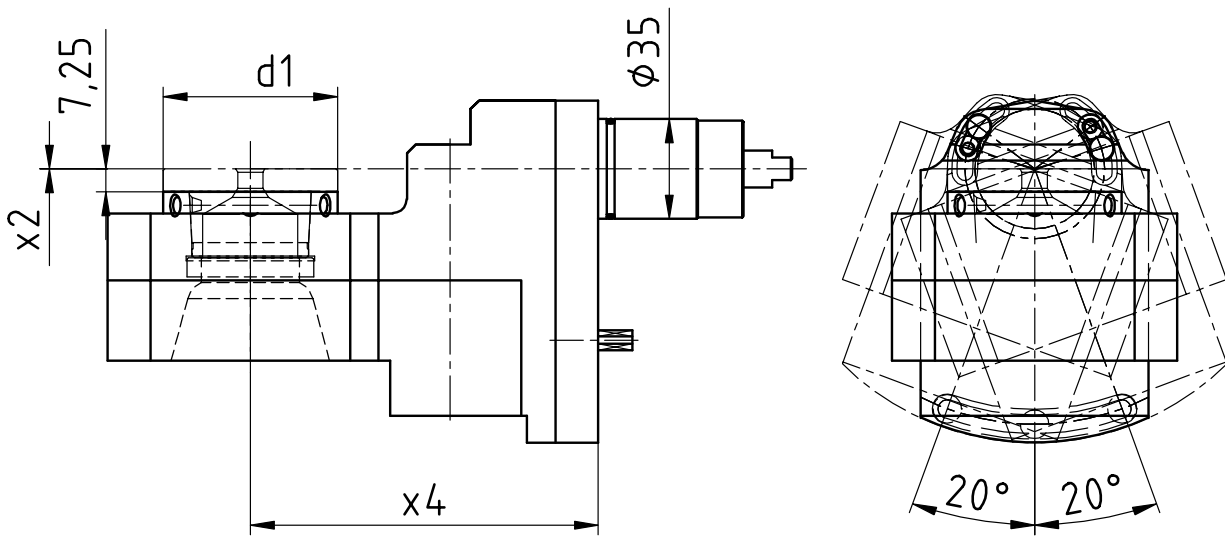

[mm]	[mm]	[mm]	Spindle Broche	[Nm]	[rpm]	Outside cooling Lubrificat. ext.	Internal cooling Lubrificat. cent.	[bar]	Order no. N° de Code	
d1	x2	x4	Spindel	T max	n max	i	Aussenkühlung	Innenkühlung	p	Bestellnummer
54	0	122	WFW 50	16	6.932	1,154:1	x			MPU.Z35.M0800.GA

Passend für Maschine: Gamma 20
 suitable machines:
 approprié pour la machine:

Tornos - Swiss Baureihen

Axial Bohr- und Fräskopf

Axial drilling and milling head

Outil de perçage et de fraisage axiale

WG 35

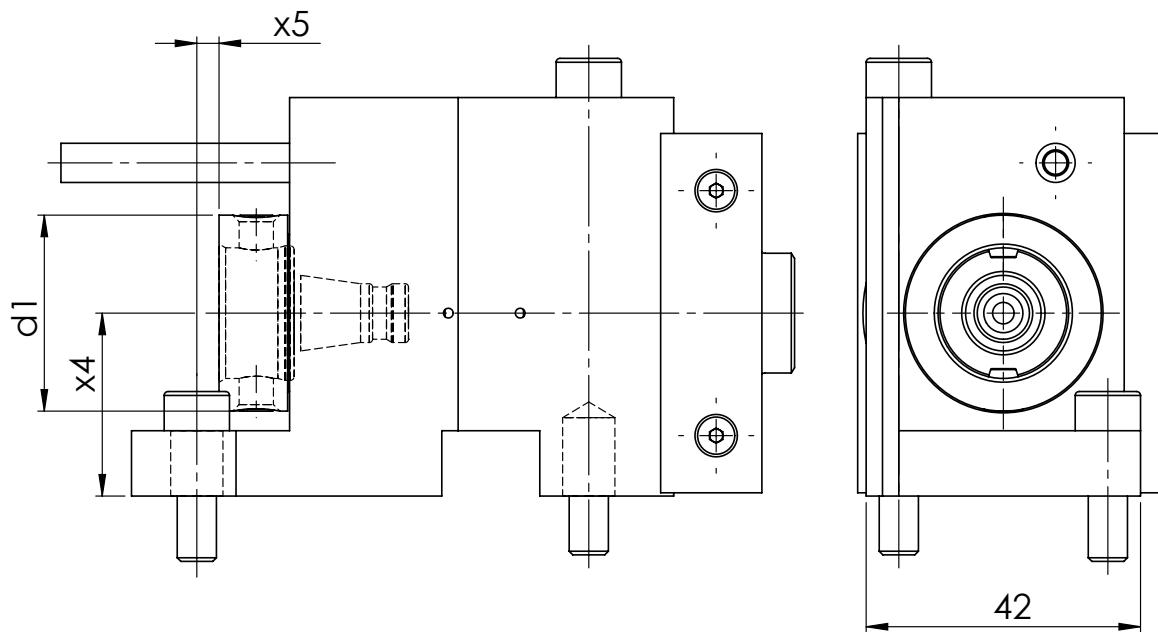
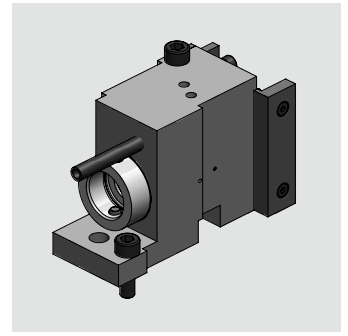

[mm]	[mm]	[mm]	Spindle Broche	[Nm]	[rpm]		Outside cooling Lubrificat. ext.	Internal cooling Lubrificat. cent.	[bar]	Order no. N° de Code
d1	x4	x5	Spindel	T max	n max	i	Aussenkühlung	Innenkühlung	p	Bestellnummer
30	28	3,4	WFB 20-12	10	6.000	1:1	x			MPU.TO.B20.H28.DGST
30	28	3,4	WFB 20-12	10	6.000	1:1	x	x	120	MPU.TO.B20.H28.DGST.IK

Passend für Maschine:	DT 13	GT 26	ST 26
suitable machines:	DT 26	GT 32	
approprié pour la machine:	GT 13	GT 32B	

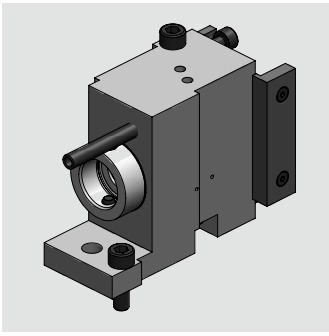

Tornos - Swiss Baureihen

Axial Bohr- und Fräskopf
 Axial drilling and milling head
 Outil de perçage et de fraisage axiale

WG 35

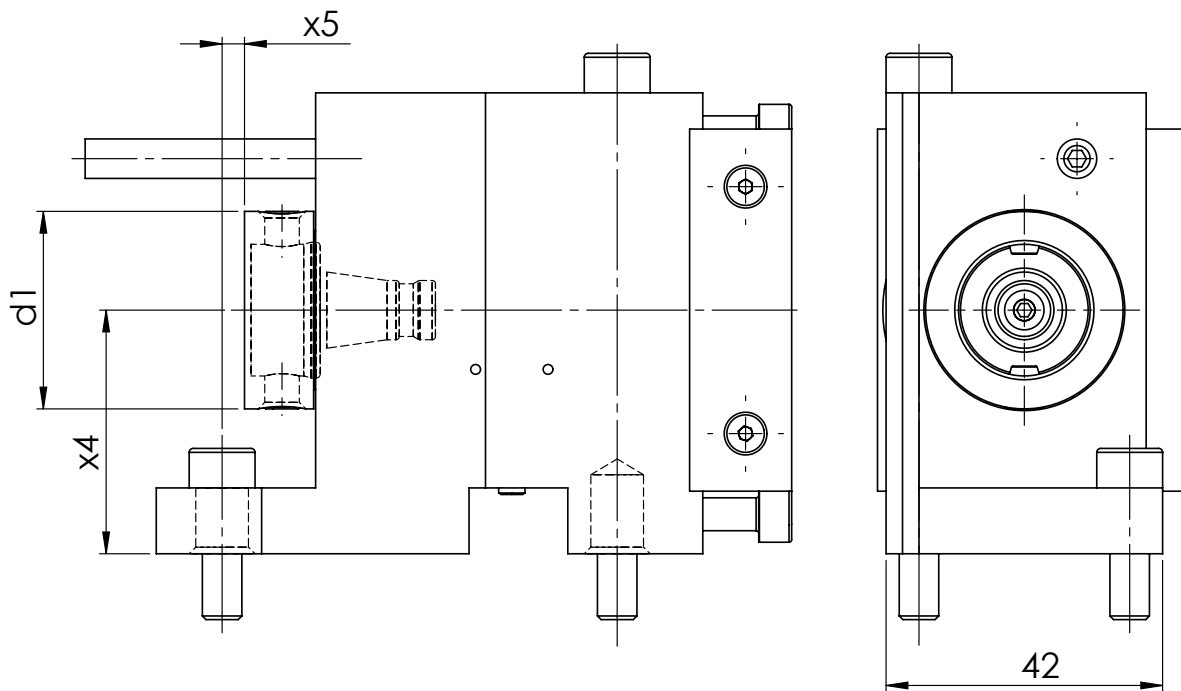

[mm]	[mm]	[mm]	Spindle Broche	[Nm]	[rpm]		Outside cooling Lubrificat. ext.	Internal cooling Lubrificat. cent.	[bar]	Order no. N° de Code
d1	x4	x5	Spindel	T max	n max	i	Aussenkühlung	Innenkühlung	p	Bestellnummer
30	37	3,4	WFB 20-12	10	6.000	1:1	x			MPU.TO.B20.H37.DGST
30	37	3,4	WFB 20-12	10	6.000	1:1	x	x	120	MPU.TO.B20.H37.DGST.IK

Passend für Maschine:	DT 26	GT 32
suitable machines:	GT 13	GT 32B
approprié pour la machine:	GT 26	ST 26

Tornos - Swiss Baureihen

Axial Bohr- und Fräskopf

Axial drilling and milling head

Outil de perçage et de fraisage axiale

WG 35

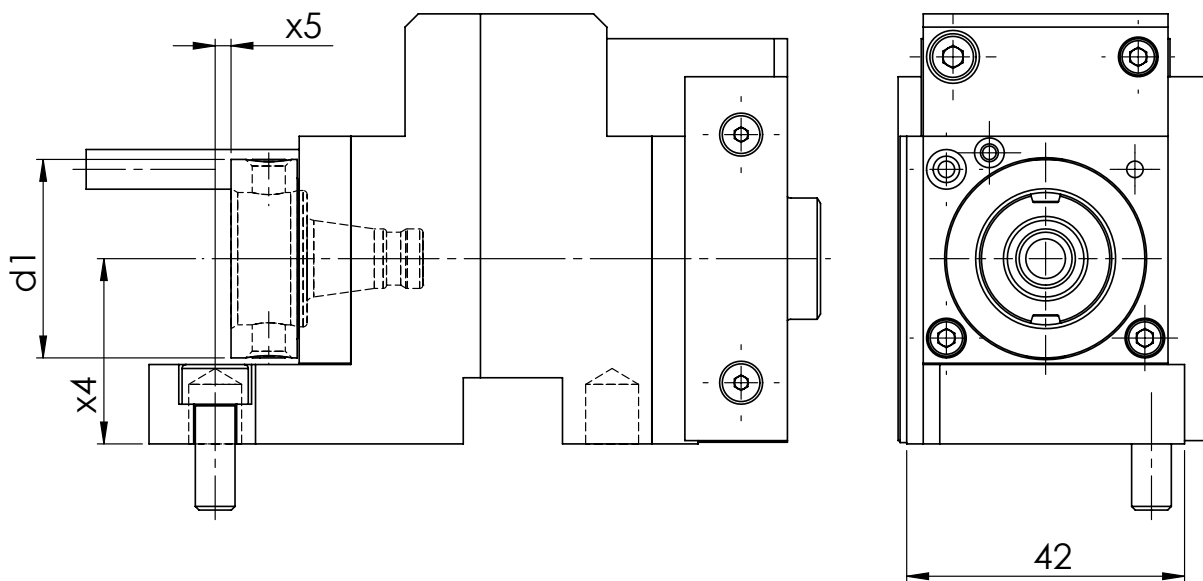
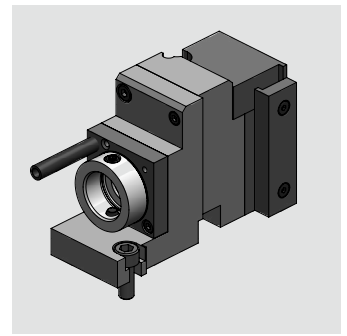

[mm]	[mm]	[mm]	Spindle Broche	[Nm]	[rpm]		Outside cooling Lubrificat. ext.	Internal cooling Lubrificat. cent.	[bar]	Order no. N° de Code
d1	x4	x5	Spindel	T max	n max	i	Aussenkühlung	Innenkühlung	p	Bestellnummer
30	28	2,4	WFB 20-12	3	18.000	1:3	x			MPU.TO.B20.S28.DGST

Passend für Maschine:	DT 13	GT 26	ST 26
suitable machines:	DT 26	GT 32	
approprié pour la machine:	GT 13	GT 32B	

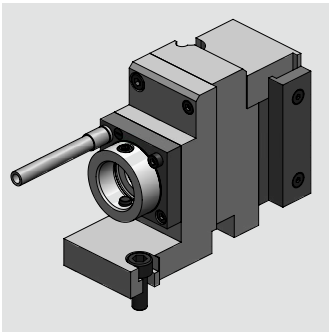

Tornos - Swiss Baureihen

Axial Bohr- und Fräskopf
 Axial drilling and milling head
 Outil de perçage et de fraisage axiale

WG 35

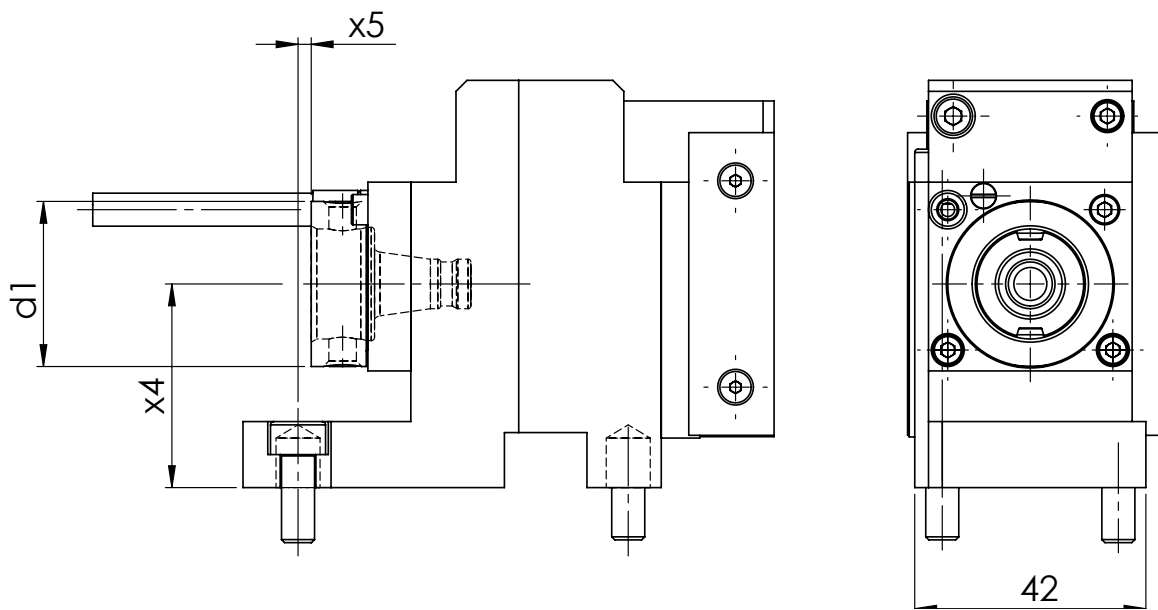

[mm]	[mm]	[mm]	Spindle Broche	[Nm]	[rpm]	Outside cooling Lubrificat. ext.	Internal cooling Lubrificat. cent.	[bar]	Order no. N° de Code
d1	x4	x5	Spindel	T max	n max	Aussenkühlung	Innenkühlung	p	Bestellnummer
30	37	2,4	WFB 20-12	3 Nm	18.000	1:3	x		MPU.TO.B20.S37.DGST

Passend für Maschine:	DT 26	GT 32
suitable machines:	GT 13	ST 26
approprié pour la machine:	GT 26	

Tornos - Swiss Baureihen

Axial Bohr- und Fräskopf

Axial drilling and milling head

Outil de perçage et de fraisage axiale

WG 35

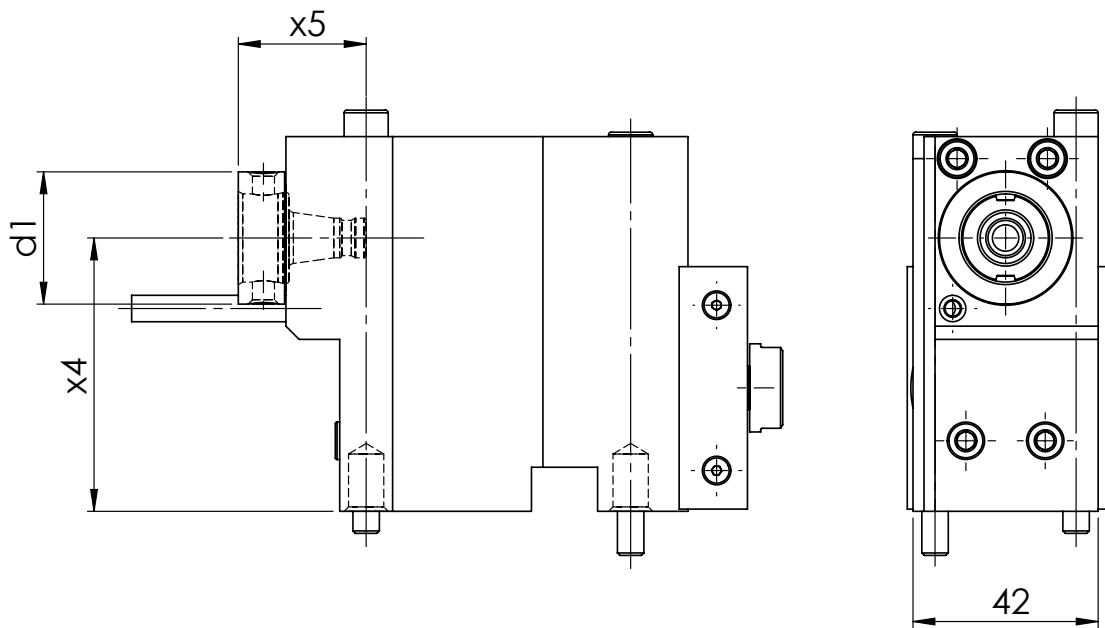
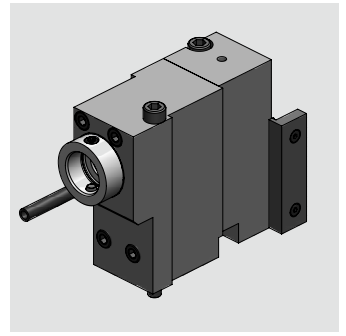

[mm]	[mm]	[mm]	Spindle Broche	[Nm]	[rpm]		Outside cooling Lubrificat. ext.	Internal cooling Lubrificat. cent.	[bar]	Order no. N° de Code
d1	x4	x5	Spindel	T max	n max	i	Aussenkühlung	Innenkühlung	p	Bestellnummer
30	62	29	WFB 20-12	20	3.000	2:1	x			MPU.TO.B20.H62.DGST

Passend für Maschine:	DT 26	GT 32
suitable machines:	GT 13	ST 26
approprié pour la machine:	GT 26	

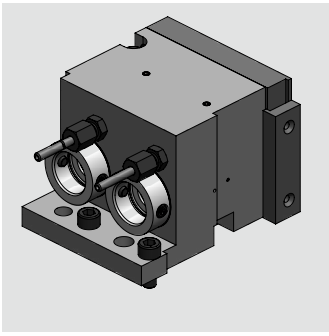

Tornos - Swiss Baureihen

Axial Bohr- und Fräskopf
 Axial drilling and milling head
 Outil de perçage et de fraisage axiale

WG 35

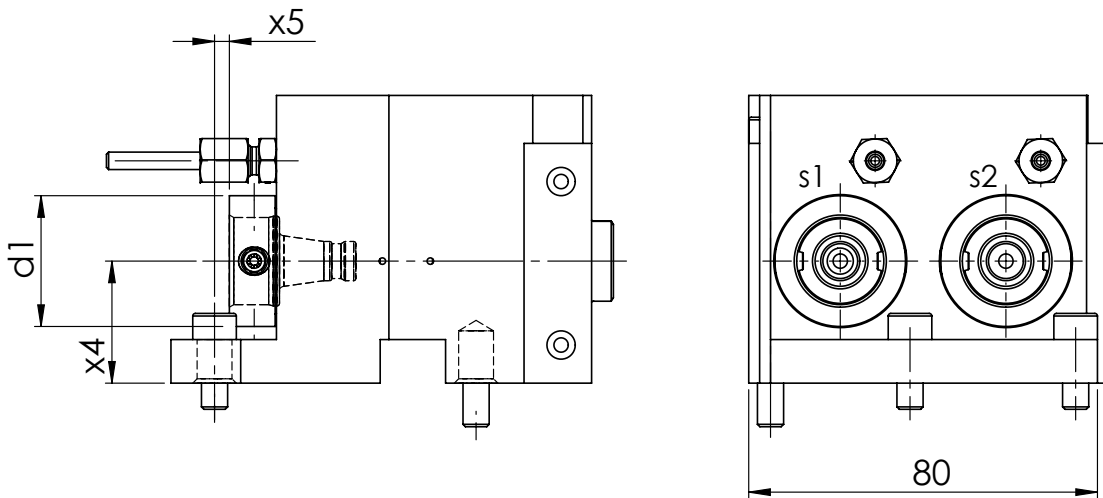

[mm]	[mm]	[mm]	Spindle Broche	[Nm]	[rpm]		Outside cooling Lubrificat. ext.	Internal cooling Lubrificat. cent.	[bar]	Order no. N° de Code
d1	x4	x5	Spindel	T max	n max	i	Aussenkühlung	Innenkühlung	p	Bestellnummer
30	28	3,4	WFB 20-12	10*	6.000*	1:1*	x	x	120	MPU.TO.B20.ME0.DGST

Passend für Maschine:	DT 13	GT 26	ST 26
suitable machines:	DT 26	GT 32	
approprié pour la machine:	GT 13	GT 32B	

* S1: 10 Nm/6.000 rpm/i=1:1
 S2: 3 Nm/18.000 rpm/i=1:3

Tornos - Swiss Baureihen

Radial Bohr- und Fräskopf

Radial drilling and milling head

Outil de perçage et de fraisage radiale

WG 35

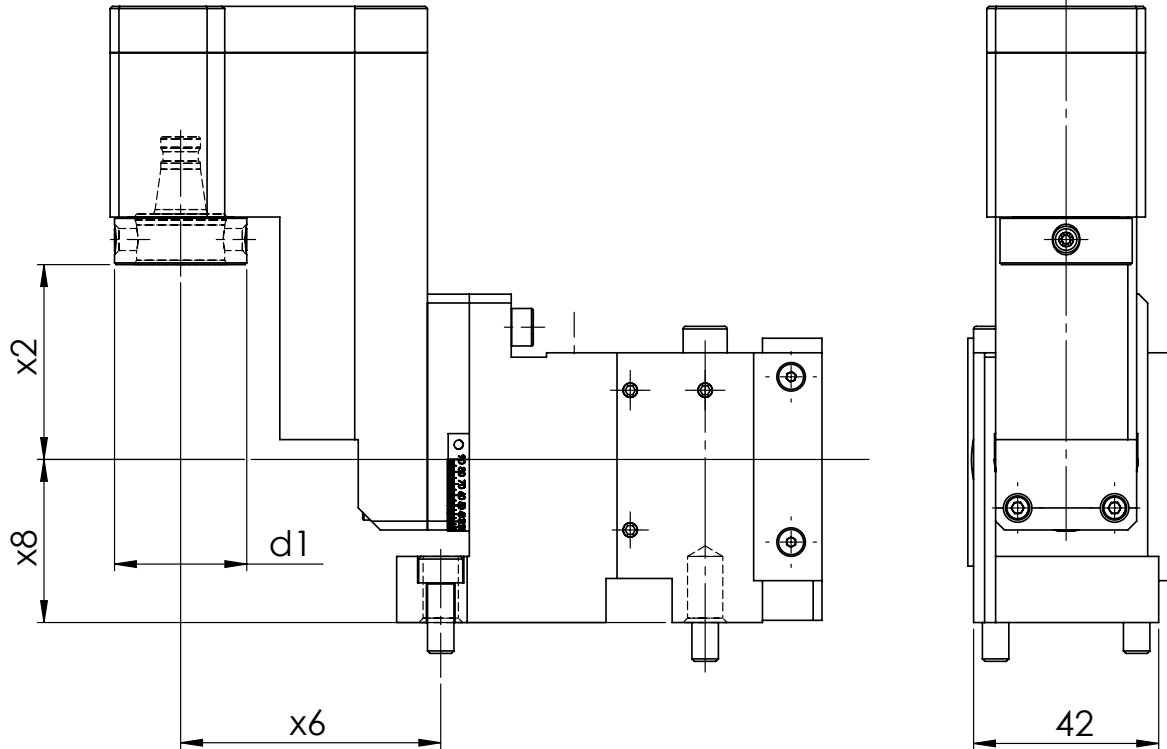
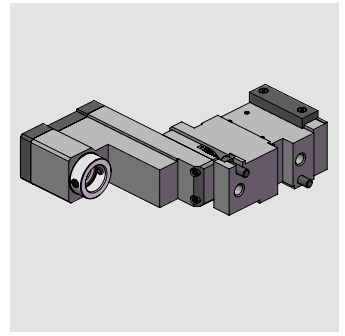

[mm]	[mm]	[mm]	[mm]	Spindle Broche	[Nm]	[rpm]		Outside cooling Lubrificat. ext.	Internal cooling Lubrificat. cent.	[bar]	Order no. N° de Code
d1	x2	x6	x8	Spindel	T max	n max	i	Aussenkühlung	Innenkühlung	p	Bestellnummer
30	44,2	59	37	WFB 20-12	3	6.000	1:1				MPU.TO.B20.S200.DGST
30	44,2	59	37	WFB 20-12	3	6.000	1:1		x	120	MPU.TO.B20.S200.DGSTIK

Passend für Maschine:	DT 26	GT 32
suitable machines:	GT 13	ST 26
approprié pour la machine:	GT 26	

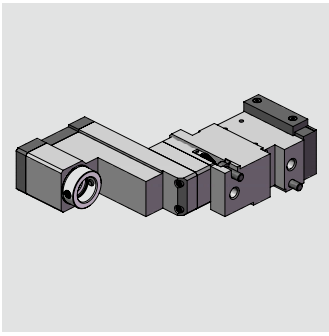

Tornos - Swiss Baureihen

Radial Bohr- und Fräskopf
 Radial drilling and milling head
 Outil de perçage et de fraisage radiale

WG 35

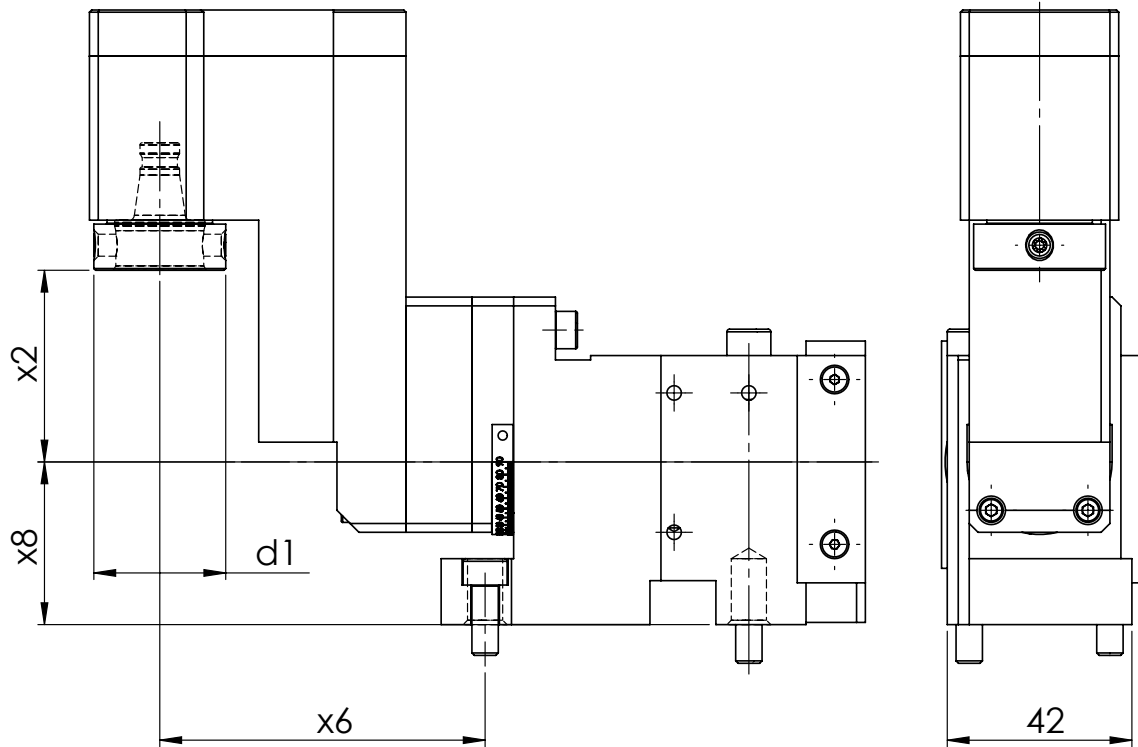

[mm]	[mm]	[mm]	[mm]	Spindle Broche	[Nm]	[rpm]		Outside cooling Lubrificat. ext.	Internal cooling Lubrificat. cent.	[bar]	Order no. N° de Code
d1	x2	x6	x8	Spindel	T max	n max	i	Aussenkühlung	Innenkühlung	p	Bestellnummer
30	44,2	74	37	WFB 20-12	3	6.000	1:1				MPU.TO.B20.S210.DGST

Passend für Maschine:	DT 26	GT 32
suitable machines:	GT 13	ST 26
approprié pour la machine:	GT 26	

Tornos - Swiss Baureihen

Radial Bohr- und Fräskopf

Radial drilling and milling head

Outil de perçage et de fraisage radiale

WG 35

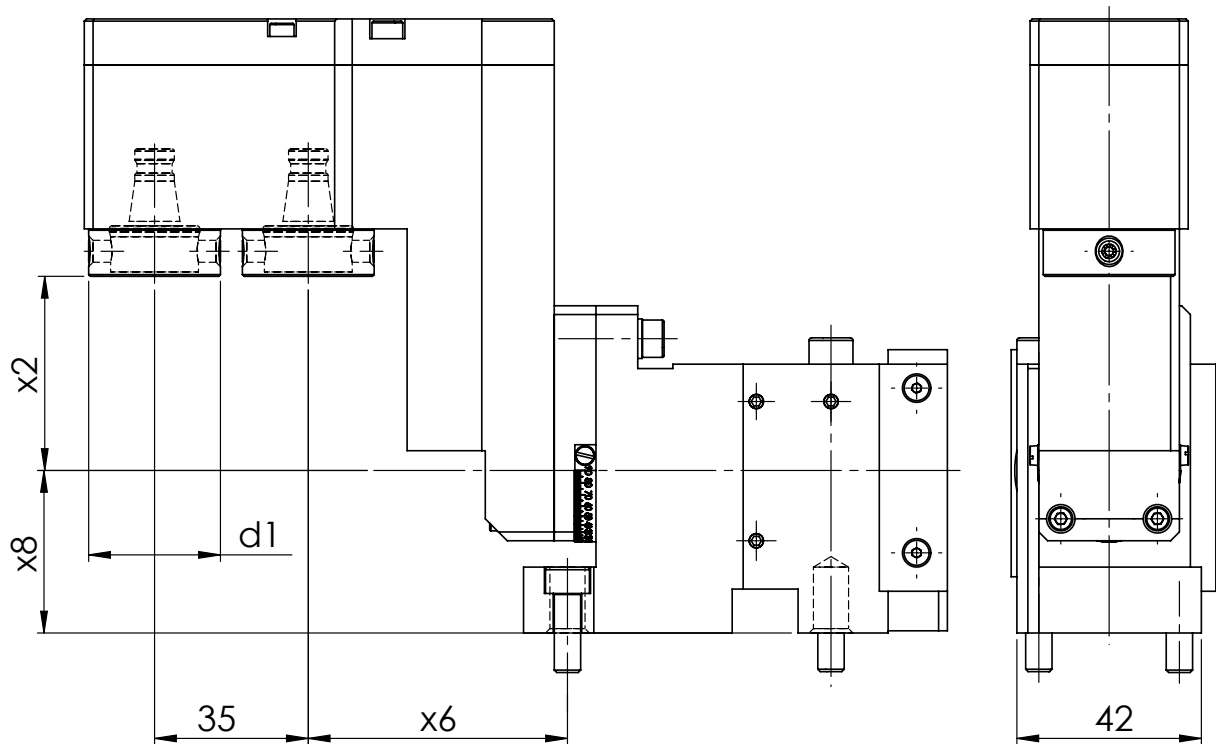
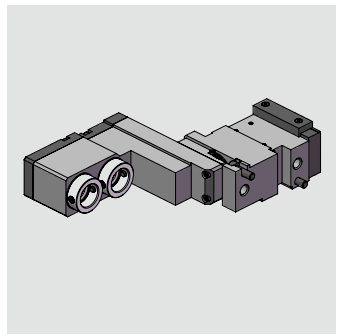

[mm]	[mm]	[mm]	[mm]	Spindle Broche	[Nm]	[rpm]		Outside cooling Lubrificat. ext.	Internal cooling Lubrificat. cent.	[bar]	Order no. N° de Code
d1	x2	x6	x8	Spindel	T max	n max	i	Aussenkühlung	Innenkühlung	p	Bestellnummer
30	44,2	59	37	WFB 20-12	3	6.000	1:1				MPU.TO.B20.2M0S200DGST

Passend für Maschine:	DT 26	GT 32
suitable machines:	GT 13	ST 26
approprié pour la machine:	GT 26	

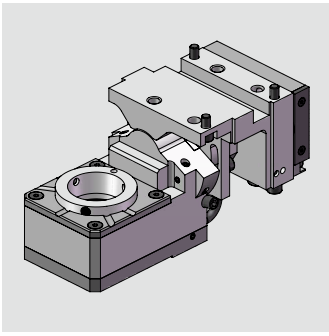

Tornos - Swiss Baureihen

Gewindewirbelapparat modular
 Thread whirling unit
 Unité de tourbillonnement

WG 35

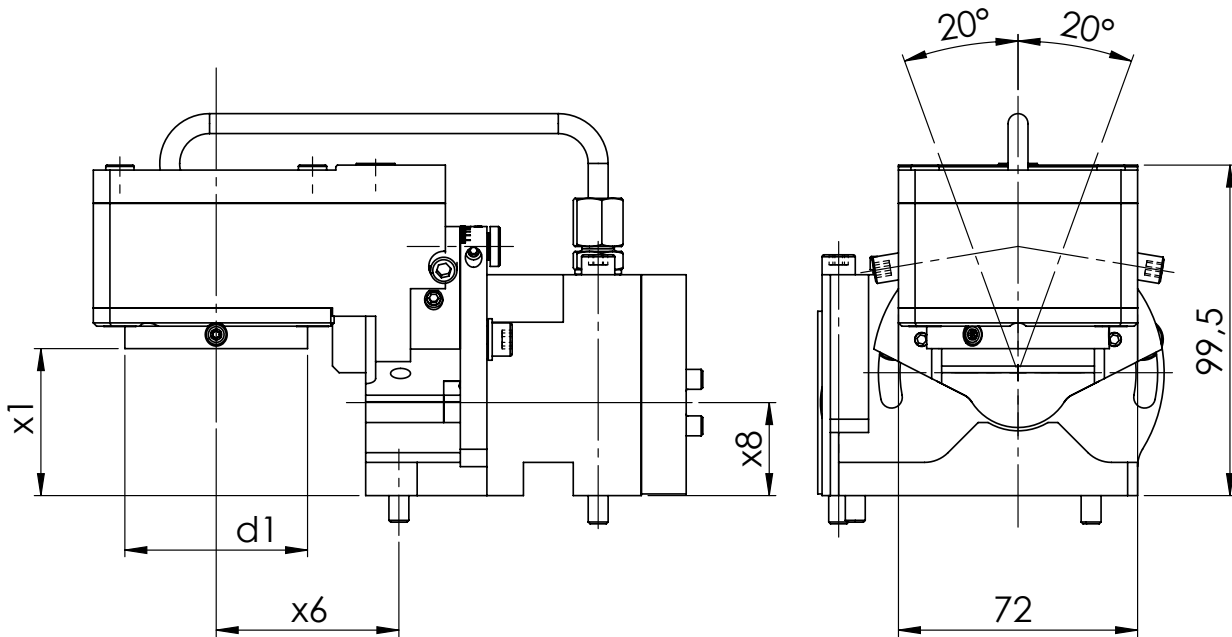

[mm]	[mm]	[mm]	[mm]	Spindle Broche	[Nm]	[rpm]		Outside cooling Lubrificat. ext.	Internal cooling Lubrificat. cent.	[bar]	Schwenk- winkel	Order no. N° de Code
d1	x1	x6	x8	Spindel	T max	n max	i	Aussenkühlung	Innenkühlung	p		Bestellnummer
55	44,25	55	28	WFW 50	16	6.000	1,75:1 x				± 20°	MPU.TO.M0800.DGST

Passend für Maschine:	DT 26	GT 32
suitable machines:	GT 13	ST 26
approprié pour la machine:	GT 26	

Tornos - Swiss Baureihen

Radial-Bohr- und Fräskopf (Mehrkantschlagen)

radial drilling and milling head (polyhedral beat)

Outil Rotatif Radial de Pertage et de Fraisage (battement polyedrique)

WG 35

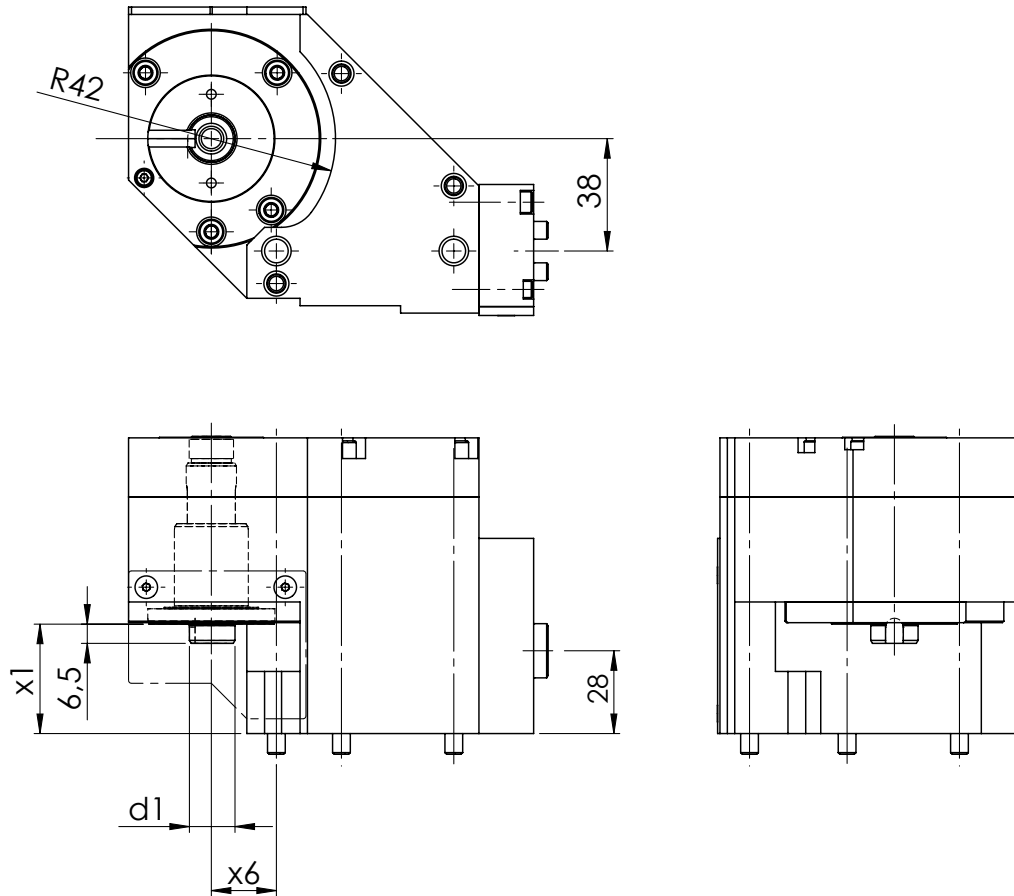
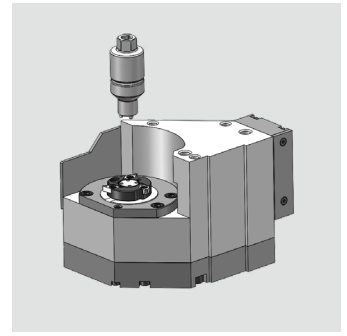

[mm]	[mm]	[mm]	Spindle Broche	[Nm]	[rpm]	Outside cooling Lubrificat. ext.	Internal cooling Lubrificat. cent.	[bar]	Order no. N° de Code
d1	x1	x6	Spindel	T max	n max	Aussenkühlung	Innenkühlung	p	Bestellnummer
16	37	22		16	3.750	1,6:1			MPU.TO.0900.DGST

Passend für Maschine:	DT 26	GT 32
suitable machines:	GT 13	ST 26
approprié pour la machine:	GT 26	

Modulare Aggregatetechnik

STATISCHE HALTER



Werkzeugtechnik



**Katalog
WF-02**



Werkzeugtechnik

WFB-Adapterpool

Indications for the customer

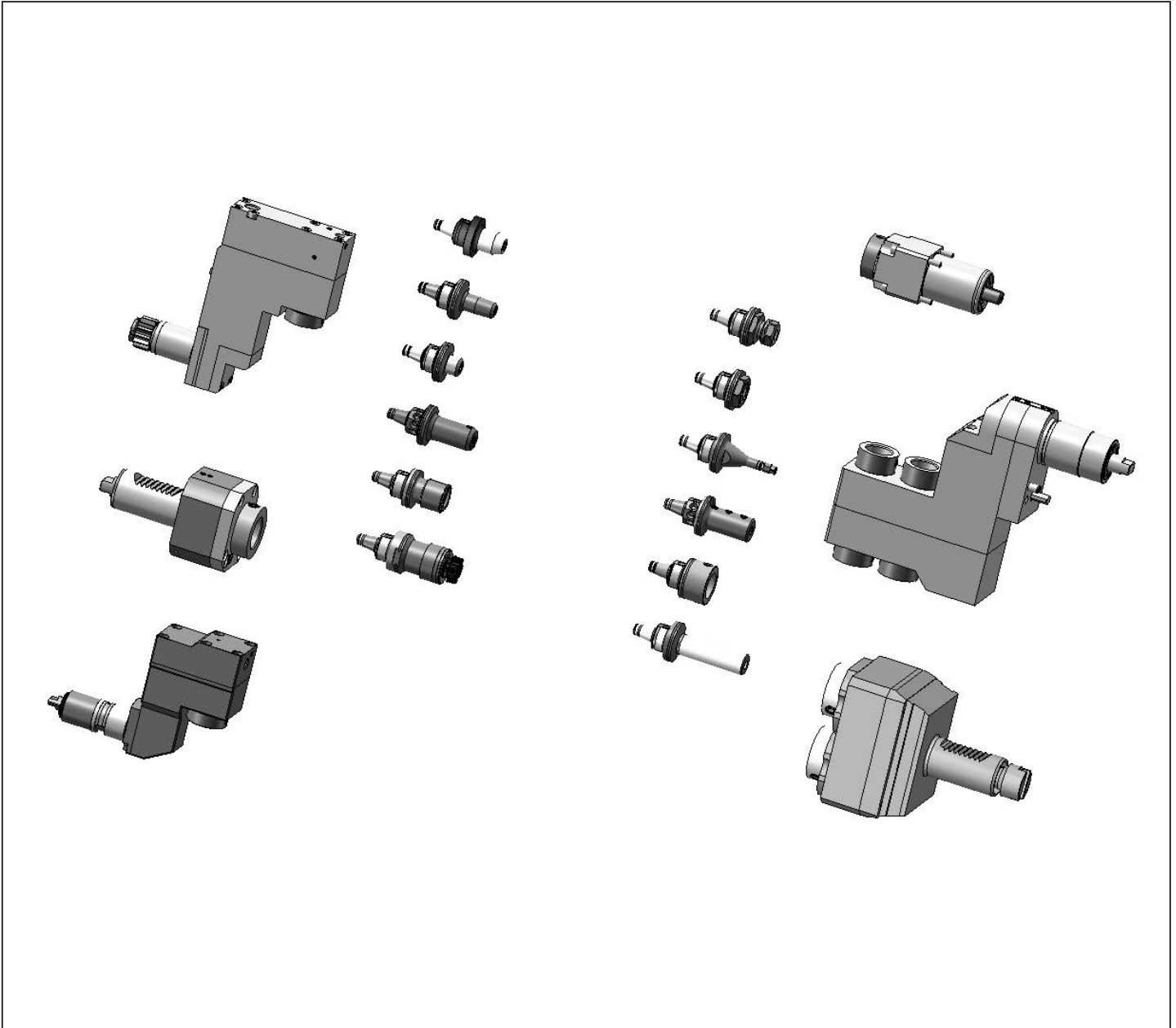

Mit den Werkzeughaltern von W&F in statischer oder angetriebener Ausführung und dem WFB-Adaptersystem haben Sie die einzigartige Möglichkeit, für sämtliche Hersteller egal ob im Kurzdrehen, Langdrehen oder Mehrspindeldrehen ein durchgängiges modulares Werkzeugsystem einzusetzen.

The W&F tool holders are in static or driven performance and beyond that, the WFB-adapter system offers you an unique option to use it for every machine manufacturer whether you are manufacturer producing with swiss type lathes, standard turning machines or multispindle turning machines, WFB is suitable.

WFB-Grundhalter (Typ WFE)

Modulare Rundschafteaufnahmen

Round shank modular

Enregistrement rond modulaire

WG 35

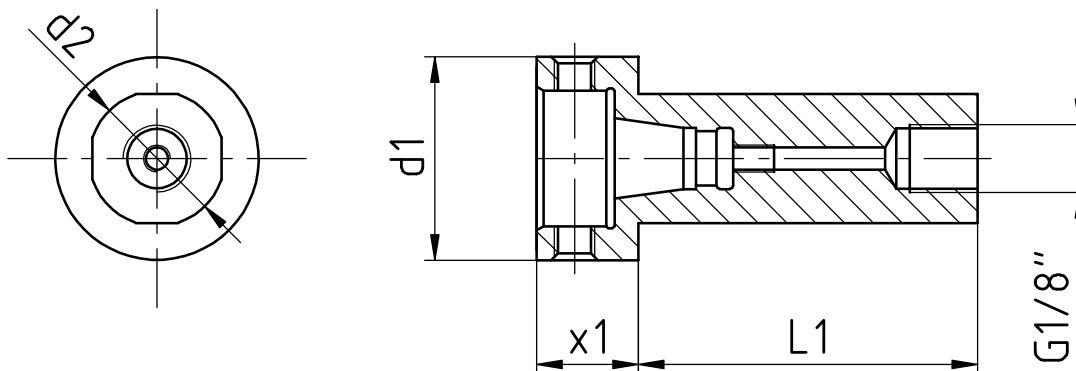
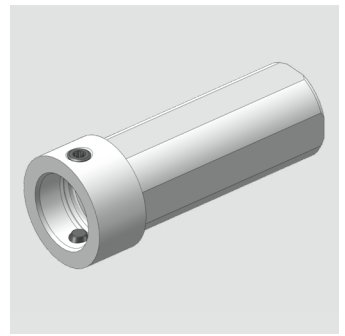

[mm]	[mm]	[mm]	[mm]	Spindle Broche Spindel	[Nm]	[rpm]		shank-type Type Schaft-Typ	Internal cooling Lubrificat. cent. Innenkühlung	[bar]	Order no. N° de Code Bestellnummer
d1	d2	x1	L1		T max	n max	i			p	
30	19,05	15	60	WFB 20-12				B	x		WFE.B20.019.060
30	20	15	30	WFB 20-12				B	x		WFE.B20.020.015.030
30	20	15	50	WFB 20-12				B	x		WFE.B20.020.015.050
30	20	14,5	110	WFB 20-12				A	x		WFE.B20.020.110
30	20	15	135	WFB 20-12				A	x		WFE.B20.020.135
30	22	15	60	WFB 20-12				B	x		WFE.B20.022.060
30	25	15	60	WFB 20-12				B	x		WFE.B20.025.060
30	25	15	130	WFB 20-12				A	x		WFE.B20.025.130
30	25	15	135	WFB 20-12				A	x		WFE.B20.025.135
30	25	15	200	WFB 20-12				B	x		WFE.B20.025.200
30	25,4	15	50	WFB 20-12				B	x		WFE.B20.0254.050
33	32	13	50	WFB 20-12				B	x		WFE.B20.032.013

Schaft-Typ
shank-type
type

A: vollrund/full round/pleine ronde

B: mit Spannflächen/with clamping surfaces/avec des surfaces de serrage

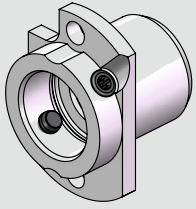

Citizen

Modularer Basishalter
 modular basic holder
 Support de base modulaire

WG 35

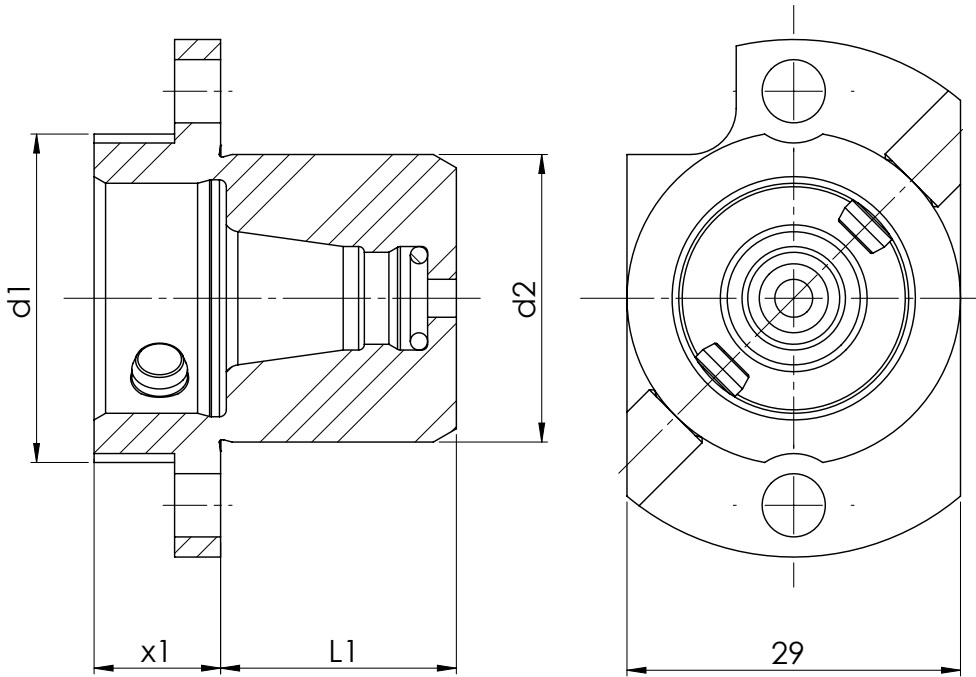

[mm]	[mm]	[mm]	[mm]	Spindle Broche	[Nm]	[rpm]		Outside cooling Lubrificat. ext.	Internal cooling Lubrificat. cent.	[bar]	Order no. N° de Code
d1	d2	x1	L1	Spindel	T max	n max	i	Aussenkühlung	Innenkühlung	p	Bestellnummer
29	25	11	20,5	WFB 20-12							WFB.020.SHT.Z25.MSC507

Hanwha

Modularer Basishalter
 modular basic holder
 Support de base modulaire

WG 35

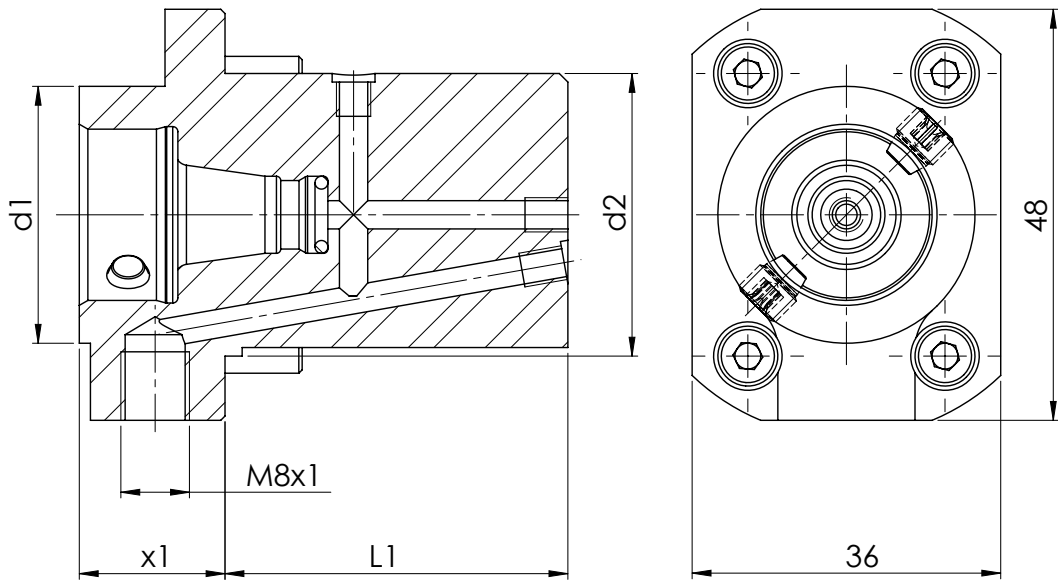
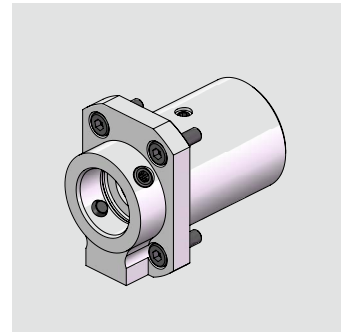

[mm]	[mm]	[mm]	[mm]	Spindle Broche	[Nm]	[rpm]		Outside cooling Lubrificat. ext.	Internal cooling Lubrificat. cent.	[bar]	Order no. N° de Code
d1	d2	x1	L1	Spindel	T max	n max	i	Aussenkühlung	Innenkühlung	p	Bestellnummer
30	33	17	40	WFB 20-12				x	x		WFB.020.SHT.XD20.001

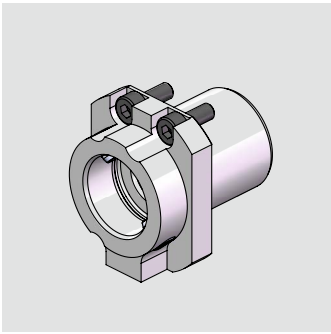

Hanwha

Modularer Basishalter
 modular basic holder
 Support de base modulaire

WG 35

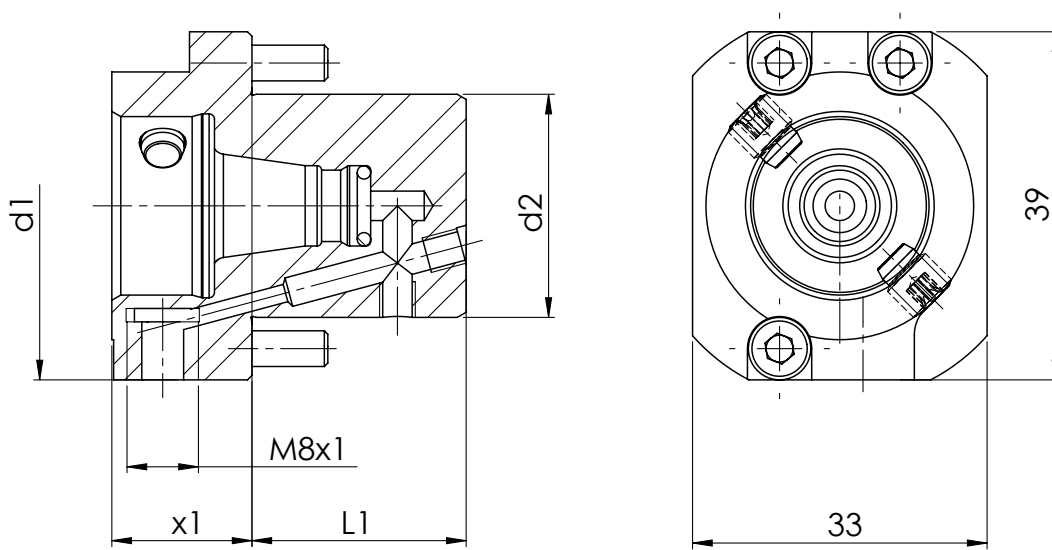

[mm]	[mm]	[mm]	[mm]	Spindle Broche	[Nm]	[rpm]		Outside cooling Lubrificat. ext.	Internal cooling Lubrificat. cent.	[bar]	Order no. N° de Code
d1	d2	x1	L1	Spindel	T max	n max	i	Aussenkühlung	Innenkühlung	p	Bestellnummer
30	25	15,7	24	WFB 20-12				x	x		WFB.020.SHT.XE20.R

Hanwha

Modularer Basishalter (Y-Versatz ausgleichbar)
 modular basic holder (Y offset compensated)
 Support de base modulaire (Y décalage)

WG 35

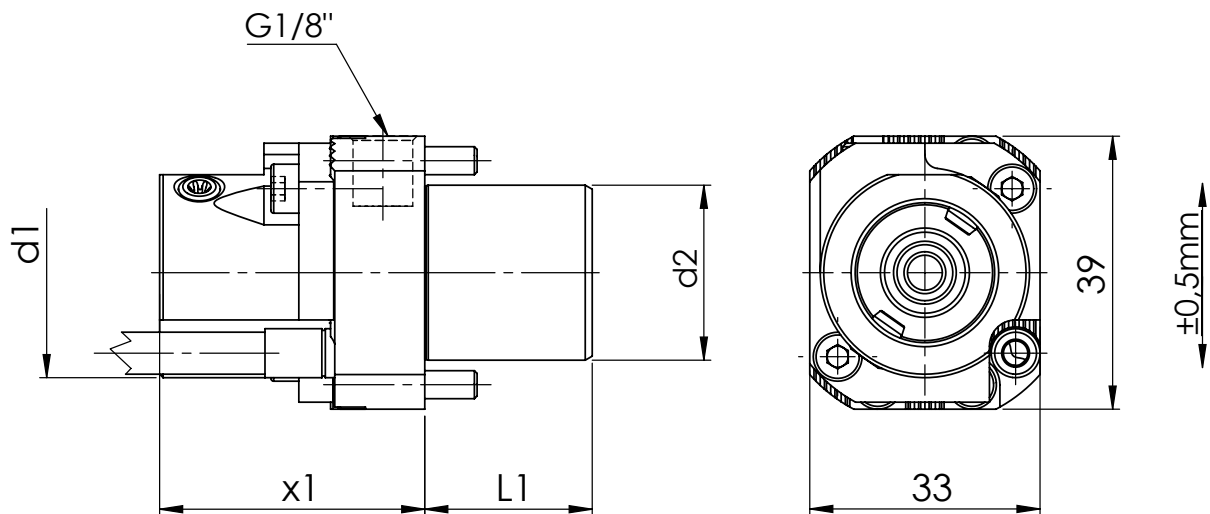
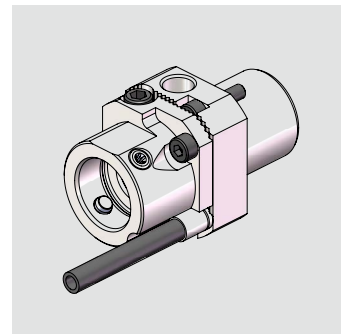

[mm]	[mm]	[mm]	[mm]	Spindle Broche Spindel	[Nm]	[rpm]		Outside cooling Lubrificat. ext. Aussenkühlung	Internal cooling Lubrificat. cent. Innenkühlung	[bar]	Order no. N° de Code Bestellnummer
d1	d2	x1	L1		T max	n max	i			p	
30	25	38	24	WFB 20-12				x	x		WFB.020.SHT.XE20.RV

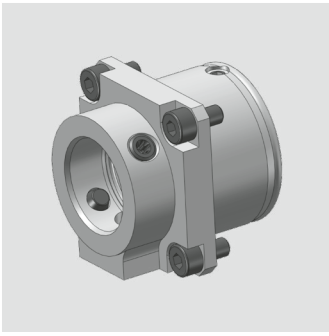

Maier

Modularer Basishalter
 modular basic holder
 Support de base modulaire

WG 35

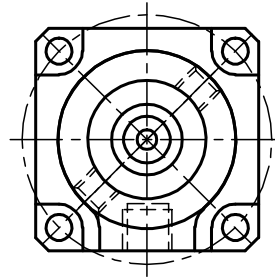
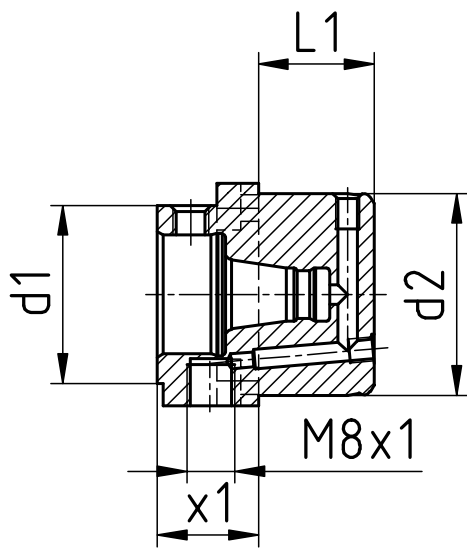

[mm]	[mm]	[mm]	[mm]	Spindle Broche	[Nm]	[rpm]		Outside cooling Lubrificat. ext.	Internal cooling Lubrificat. cent.	[bar]	Order no. N° de Code
d1	d2	x1	L1	Spindel	T max	n max	i	Aussenkühlung	Innenkühlung	p	Bestellnummer
30	34	17	19,5	WFB 20-12				x	x		WFB.020.SHT.Z34.019,5

Star

Modularer Basishalter (Y-Versatz ausgleichbar)
 modular basic holder (Y offset compensated)
 Support de base modulaire (Y décalage)

WG 35

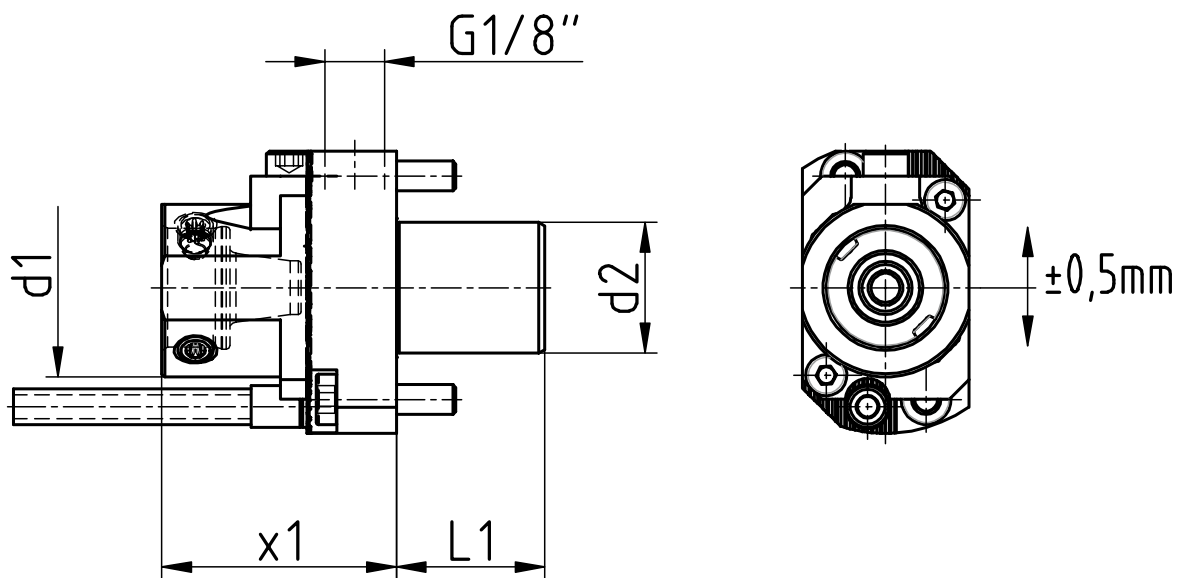
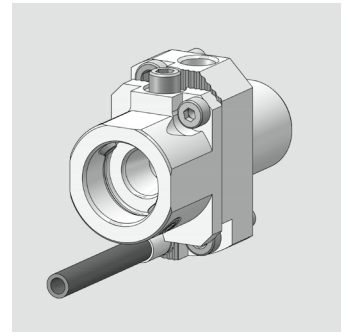

[mm]	[mm]	[mm]	[mm]	Spindle Broche	[Nm]	[rpm]		Outside cooling Lubrificat. ext.	Internal cooling Lubrificat. cent.	[bar]	Order no. N° de Code
d1	d2	x1	L1	Spindel	T max	n max	i	Aussenkühlung	Innenkühlung	p	Bestellnummer
30	22	39,5	25	WFB-20-12				x	x		WFB.020.SHT.541-61-00

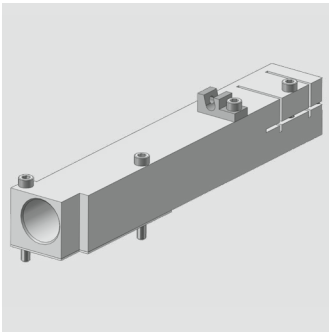

Tornos EvoDECO 10

Basishalter
basic holder
Support de base

WG 35

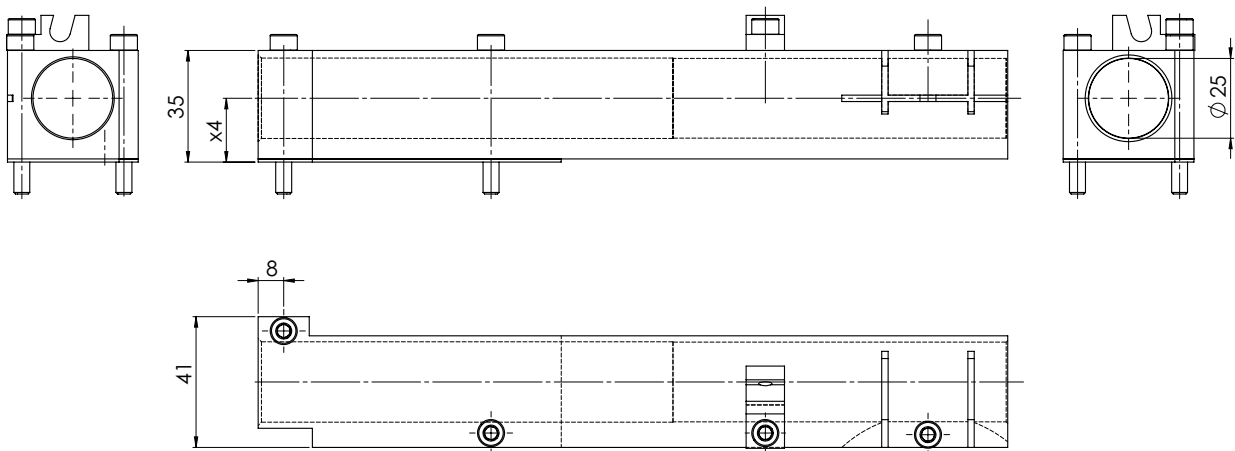

[mm]	Spindle Broche	[Nm]	[rpm]	Outside cooling Lubrificat. ext.	Internal cooling Lubrificat. cent.	[bar]	Order no. N° de Code
x4	Spindel	T max	n max	i	Aussenkühlung Innenkühlung	p	Bestellnummer

Tornos EvoDECO 13

Basishalter
basic holder
Support de base

WG 35

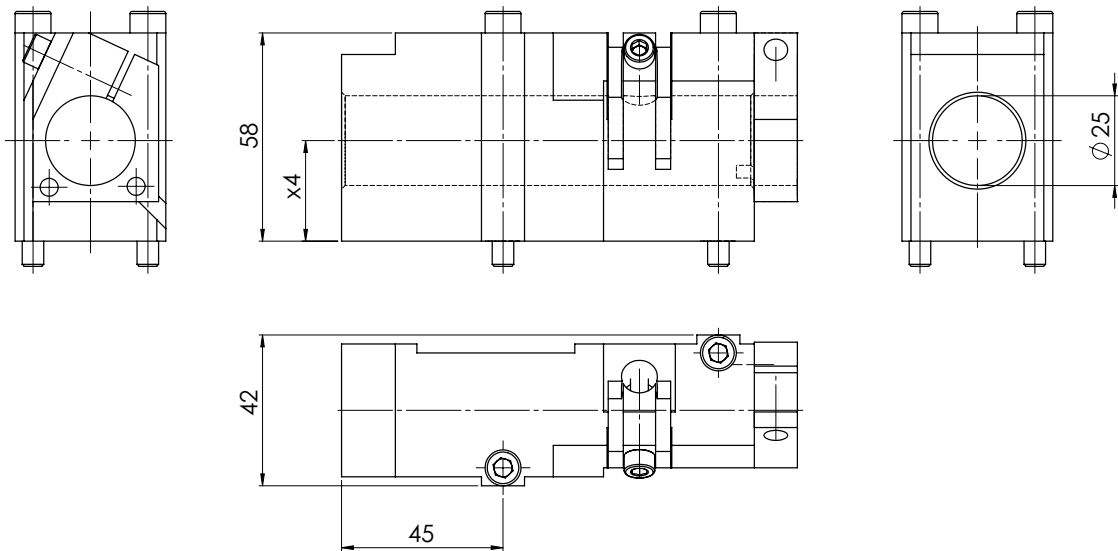
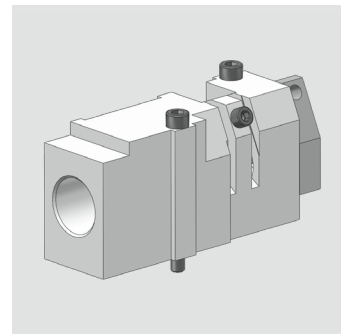

[mm]	Spindle Broche	[Nm]	[rpm]	Outside cooling Lubrificat. ext.	Internal cooling Lubrificat. cent.	[bar]	Order no. N° de Code
x4	Spindel	T max	n max	i	Aussenkühlung Innenkühlung	p	Bestellnummer

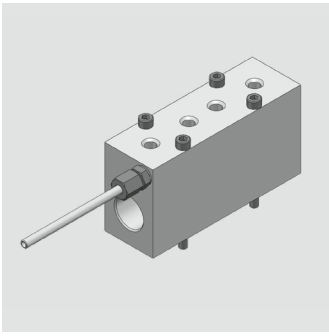

Tornos EvoDECO 20

Basishalter
basic holder
Support de base

WG 35

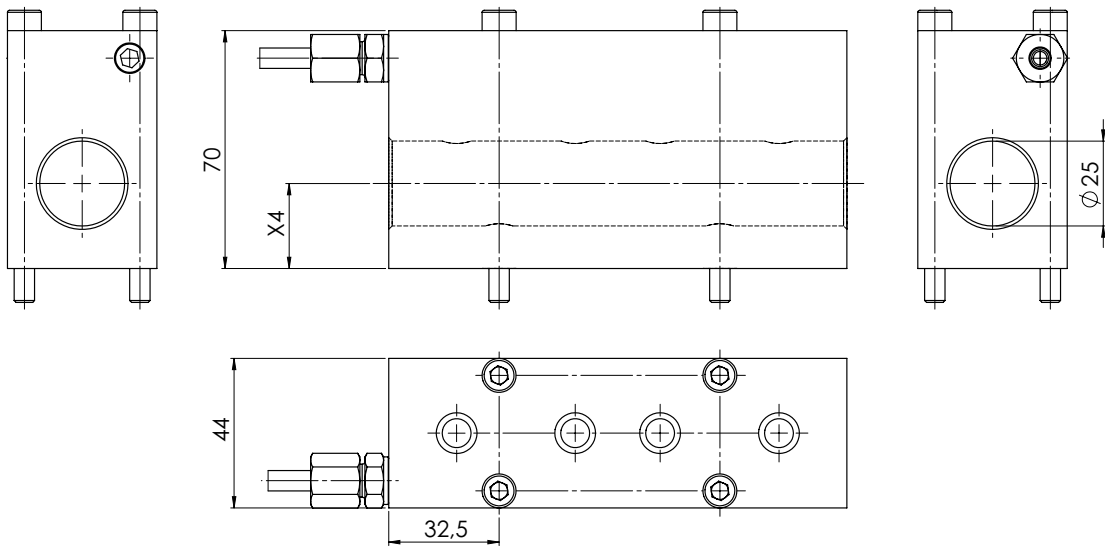

[mm]	Spindle Broche	[Nm]	[rpm]	Outside cooling Lubrificat. ext.	Internal cooling Lubrificat. cent.	[bar]	Order no. N° de Code
x4	Spindel	T max	n max	i	Aussenkühlung Innenkühlung	p	Bestellnummer

25

WFE.025.H25.DE20

Tornos Swiss Baureihe

Modularer Basishalter (Y-Versatz ausgleichbar)
 modular basic holder (Y offset compensated)
 Support de base modulaire (Y décalage)

WG 35

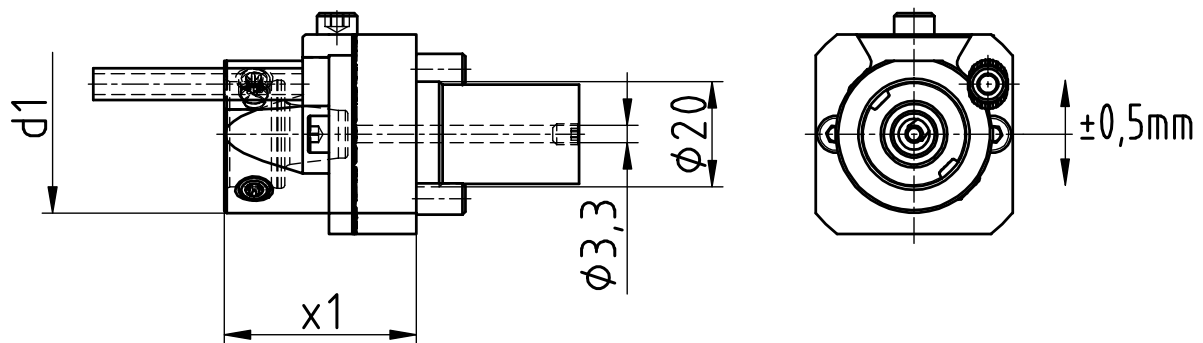
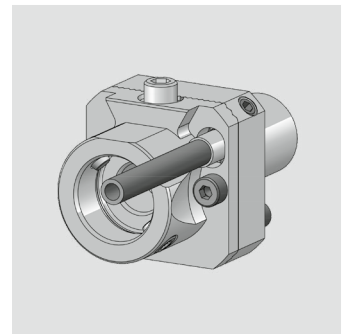

[mm]	[mm]	[mm]	[mm]	Spindle Broche	[Nm]	[rpm]		Outside cooling Lubrificat. ext.	Internal cooling Lubrificat. cent.	[bar]	Order no. N° de Code
d1	d2	x1	L1	Spindel	T max	n max	i	Aussenkühlung	Innenkühlung	p	Bestellnummer
30	20	36,5	31	WFB 20-12				x	x		WFB.020.SHT.DGST.R

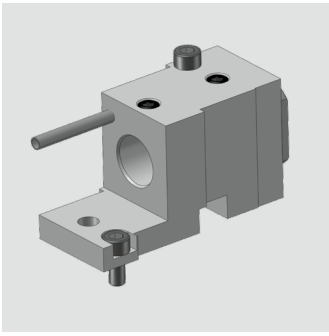

Tornos Swiss Baureihe

Modularer Basishalter
 modular basic holder
 Support de base modulaire

WG 35

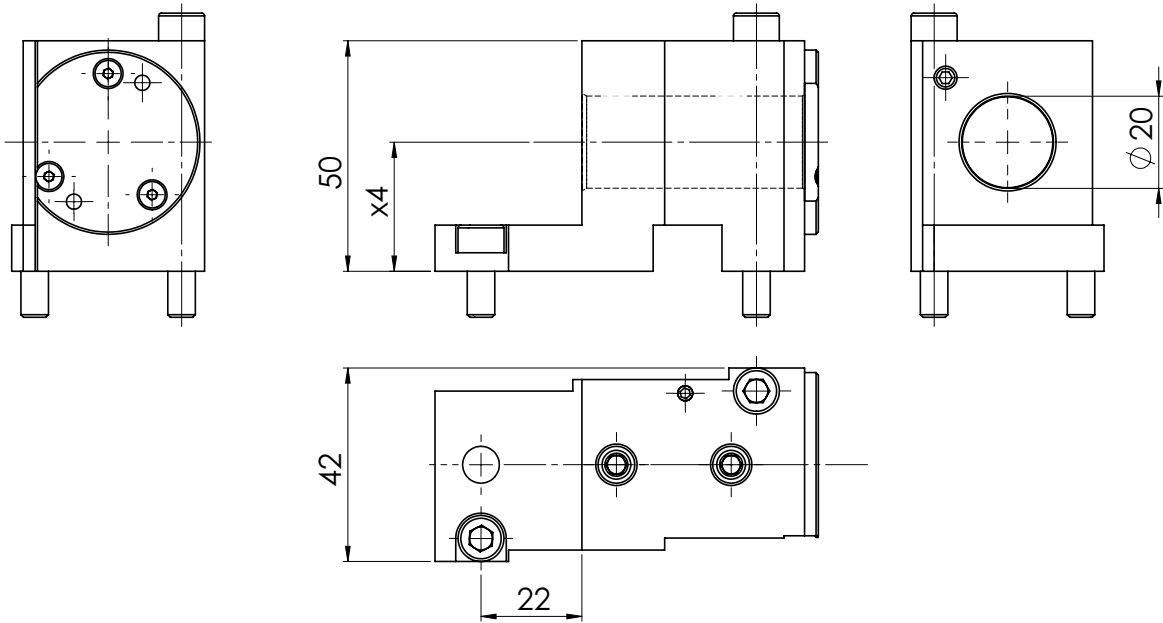

[mm]	Spindle Broche Spindel	[Nm] T max	[rpm] n max	i	Outside cooling Lubrificat. ext. Aussenkühlung	Internal cooling Lubrificat. cent. Innenkühlung	[bar] p	Order no. N° de Code Bestellnummer
x4					x	x		WFE.020.H28.DGST

Passende Rundschaftaufnahmen siehe Seite 9.1
 matching round shanks see page 9.1

Tornos Swiss Baureihe

Modularer Basishalter
 modular basic holder
 Support de base modulaire

WG 35

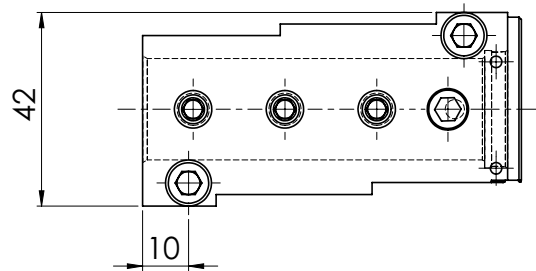
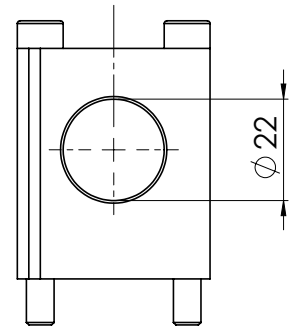
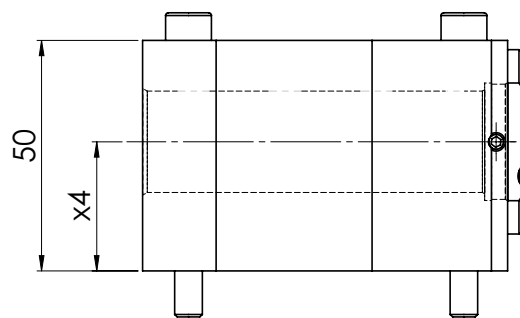
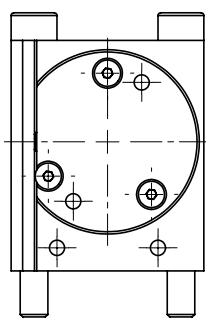
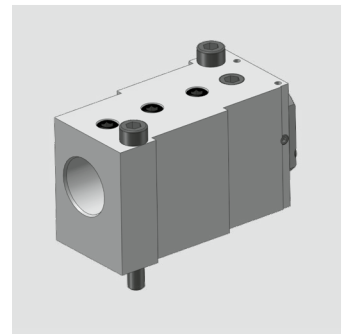

[mm]	Spindle Broche Spindel	[Nm] T max	[rpm] n max	i	Outside cooling Lubrificat. ext. Aussenkühlung	Internal cooling Lubrificat. cent. Innenkühlung	[bar] p	Order no. N° de Code Bestellnummer
x4					x	x		WFE.022.H28.DGST

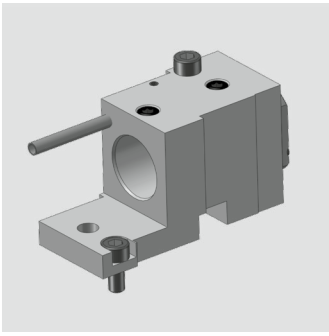

Tornos Swiss Baureihe

Modularer Basishalter
 modular basic holder
 Support de base modulaire

WG 35

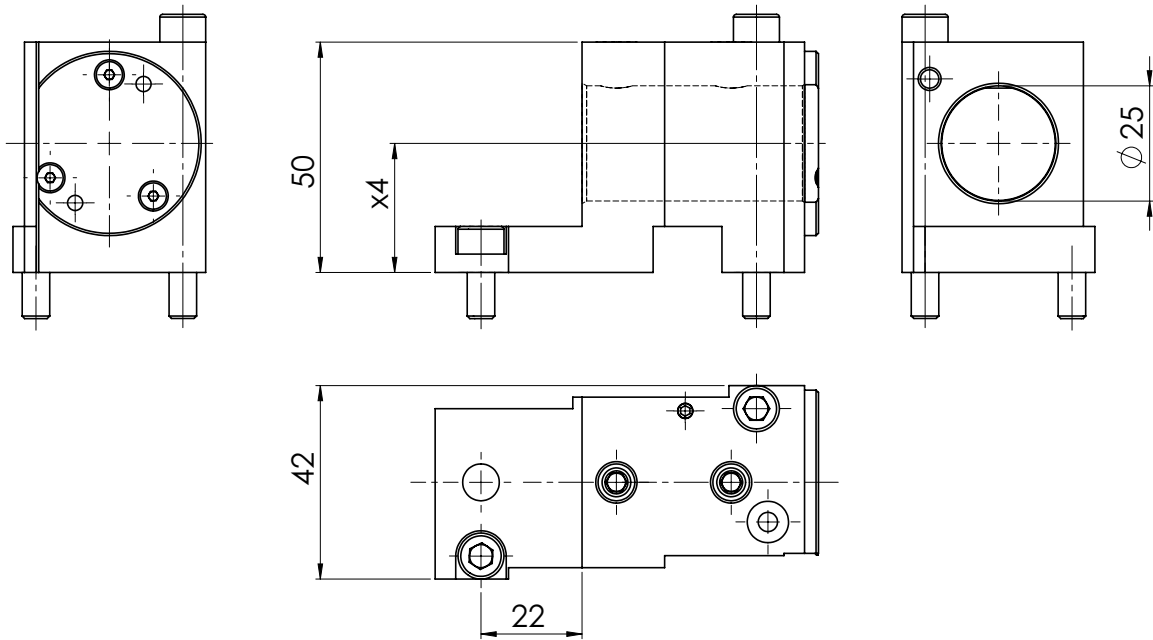

[mm]	Spindle Broche	[Nm]	[rpm]	Outside cooling Lubrificat. ext.	Internal cooling Lubrificat. cent.	[bar]	Order no. N° de Code
x4	Spindel	T max	n max	i	Aussenkühlung Innenkühlung	p	Bestellnummer
28				x	x		WFE.025.H28.DGST

Passende Rundschafftaufnahmen siehe Seite 9.1
 matching round shanks see page 9.1

Tornos Swiss Baureihe

Modularer Basishalter
 modular basic holder
 Support de base modulaire

WG 35

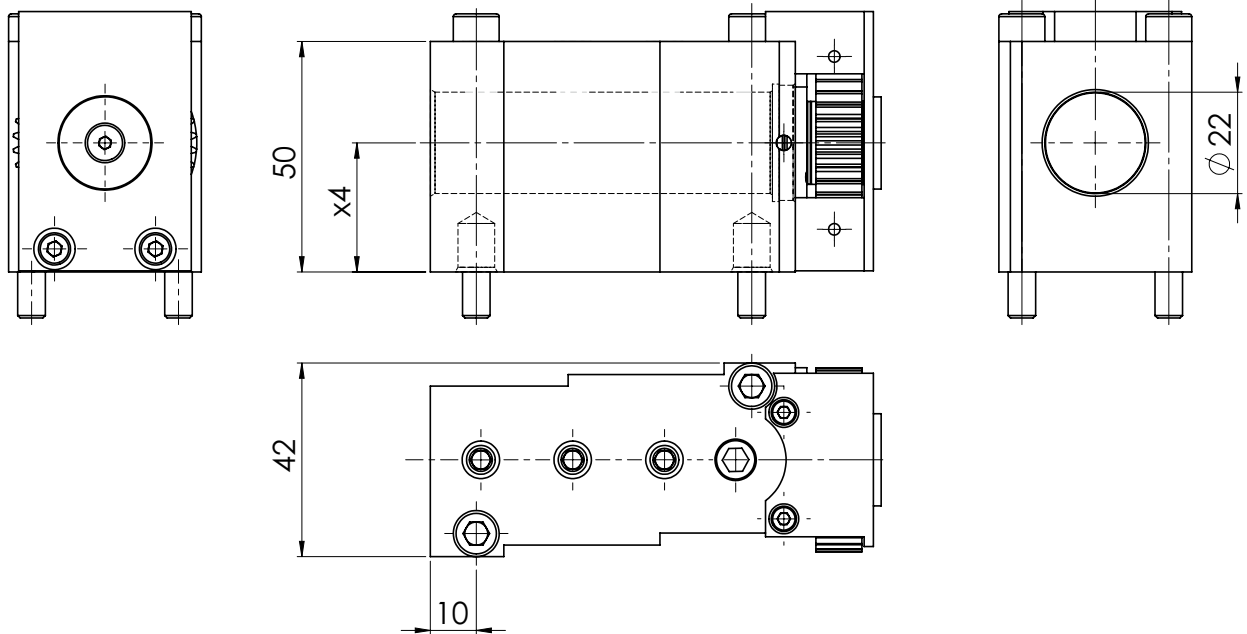
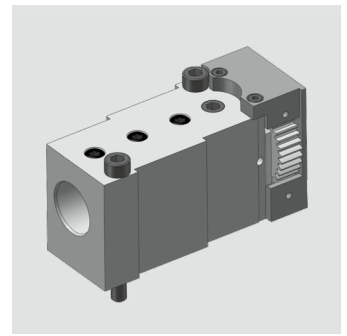

[mm]	Spindle Broche	[Nm]	[rpm]	Outside cooling Lubrificat. ext.	Internal cooling Lubrificat. cent.	[bar]	Order no. N° de Code
x4	Spindel	T max	n max	i	Aussenkühlung Innenkühlung	p	Bestellnummer

28					x		MPU.TO.D22.H28.DGST
----	--	--	--	--	---	--	---------------------

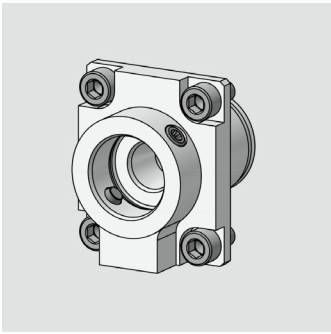

Tsugami

Modularer Basishalter
 modular basic holder
 Support de base modulaire

WG 35

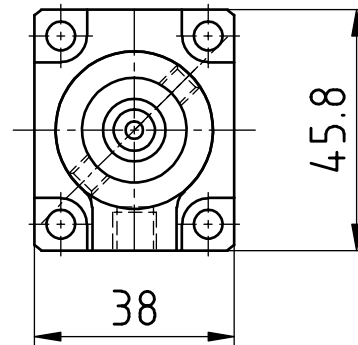
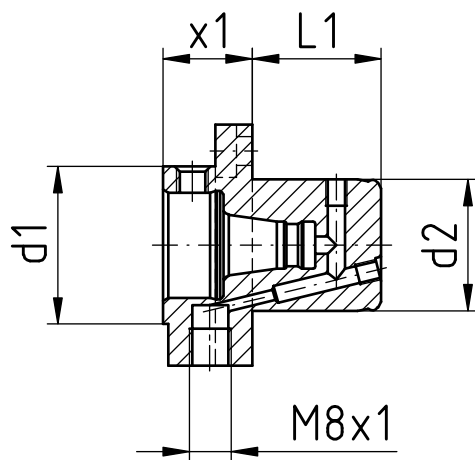

[mm]	[mm]	[mm]	[mm]	Spindle Broche	[Nm]	[rpm]		Outside cooling Lubrificat. ext.	Internal cooling Lubrificat. cent.	[bar]	Order no. N° de Code
d1	d2	x1	L1	Spindel	T max	n max	i	Aussenkühlung	Innenkühlung	p	Bestellnummer
30	25	17	24,5	WFB 20-12				x	x		WFB.020.SHT.Z25.TS.R

Modulare Drehhalter

WF-MICRO

WF
&

Werkzeugtechnik

WF-Micro
think future



Katalog
MI-02



Werkzeugtechnik

Inhaltsverzeichnis für WF-MICRO

Table of contents for WF-MICRO
Table des matières pour WF-MICRO

Beschreibung / Description	Seite / Page
Produktvorteile Product advantages WF-Micro	10.1
Gebrauch und Wartung der WF-Micro Schnittstelle Handling and maintenance for WF-Micro connection	10.2
WF-Micro Funktionsprinzip WF-Micro function	10.3
WFMS-Statischer Halter WFMS-Static holder	10.4
WFMS-Drehhalter WFMS-Turning tool holder	10.5 - 10.9
WFMS-Drehhalter System Horn WFMS-Turning holder with internal cooling Typ Horn	10.10 - 10.17
WFMS-Rohlinge und Grundhalter WFMS-Blanks and basic holders	10.18

WG = Warengruppe
Article group
Groupe de marchandise

WG 11 = _____

WG 35 = _____

WG 40 = _____

Einsparungspotential durch WF-MICRO



Werkzeugtechnik

WF-Micro – das innovative modulare Adaptersystem für statische Werkzeuge auf allen gängigen Langdrehmaschinen und Mehrspindeldrehautomaten, das Ihnen eine bis dato unerreichbare Produktivität ermöglicht.

Der Wechsel der Wendeschneidplatten ist oft durch die Bauweise der Maschinen nur bedingt möglich. Meist müssen die kompletten Grundhalter ausgebaut werden. Dies ist sehr zeitaufwändig und führt zu hohen Stillstandszeiten.

Das gehört jetzt der Vergangenheit an.

Die modularen WF-Micro Halter sind in den Ausführungen 10x10, 12x12, 1/2"x1/2" und 16x16 lieferbar.

- Grundhalter mit integriertem Kühlmittelanschluss ermöglichen den Einsatz auf jeder möglichen Position in der Maschine.
- Die einfache Einhandbedienung erlaubt einen sicheren und einfachen Wechsel der Wendeschneidplattenadapter.
- Sämtliche Adapter können außerhalb der Maschine voreingestellt und vermessen werden.
- Der Werkzeugwechsel erfolgt innerhalb weniger Sekunden.
- Die Rüst- und Nebenzeiten werden auf ein Minimum reduziert und die Produktivität Ihrer Maschine auf ein Maximum gesteigert.
- Die Konzeption der Schnittstelle als Kurzkegel mit Plananlage und zylindrischer Abstützung garantiert eine exakte Lagepositionierung und Genauigkeit im einstelligen μ -Bereich.
- Die schwingungsdämpfende Eigenschaft der WF-Micro Schnittstelle ergibt deutlich bessere Bearbeitungsergebnisse und längere Standzeiten der Wendeschneidplatten.

**Nutzen Sie die Vorteile von WF-Micro
und steigern Sie ihre Produktivität.**



Werkzeugtechnik

Gebrauch und Wartung

Handling and maintenance

Hinweis zur Befestigung

Zunächst einen Kegelgewindestift unter Verwendung eines Drehmoment-Schraubendrehers anziehen, dabei 1-2 mal lösen und wieder anziehen. Dadurch wird eine optimale Positionierung der Bauteile erreicht. Der 2. Kegelgewindestift wird nun ebenfalls(wie oben angeführt) angezogen.

Empfohlenes Anzugsdrehmoment beträgt beim WFM-System: 4 Nm.

Pflege und Wartung

Die Oberfläche der Planflächen, der Kegelbohrung und Kegelzapfen sind vor Gebrauch zu reinigen und mit einem Öl-Schmierfilm zu versehen. Um eine optimale Befestigung und Lösbarkeit der Kegelgewindestifte zu erreichen, wird empfohlen die Kegelgewindestifte mit z.B. Molykote 1000 oder einer ähnlichen Heiss-Schraubenpaste zu behandeln.

Advice for fixing

First tighten one threaded pin, in doing so 1 or 2 times unscrew and tighten again. Thereby you get an optimum positioning of the components. The second threaded taper pin you will thighten with the same method.

Recommended locking torque for the WFM System is 4 Nm.

Support and maintenance

The surface of the face, the cone drill and cone pin must be cleaning and lubricate with oil before using. To reach an optimum fixing and resolvability of the threaded taper pins, are recommended to use for example Molykote 1000 or something similar.

WF-MICRO Funktionsprinzip

WF-MICRO function

WF
&
Werkzeugtechnik

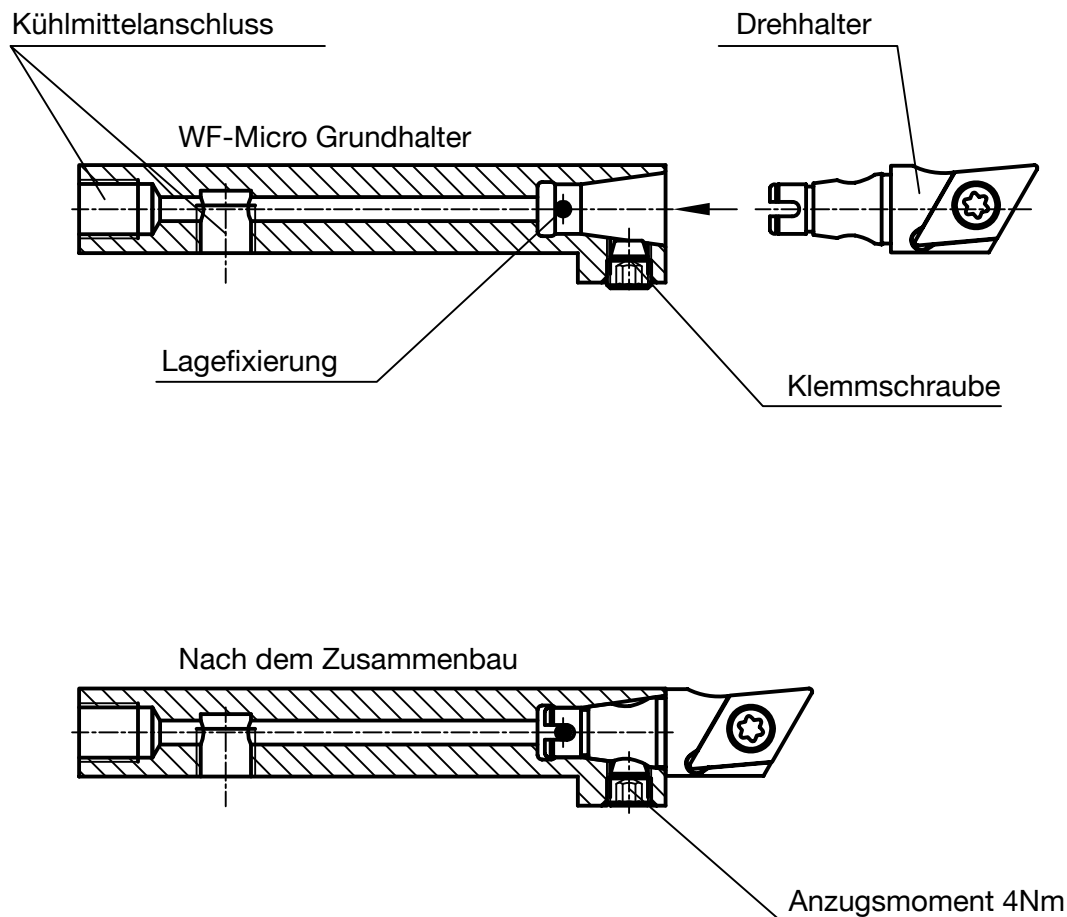

Vorteile des WF-Micro Systems

- Einfache Bedienung (nur eine Klemmschraube)
- Garantierte Lagefixierung beim Fügen
- Höchste Präzision und Steifigkeit durch patentiertes Kegel-Plananlage-System mit zyl. Abstützung
- Ausserhalb der Maschine voreinstellbar

advantages of the WF-Micro system

- simple handling (only one screw)
- guaranteed positioning
- highest precision and stiffness through patented taper and face system cylindrical stabilizer
- adjustment outside the machine

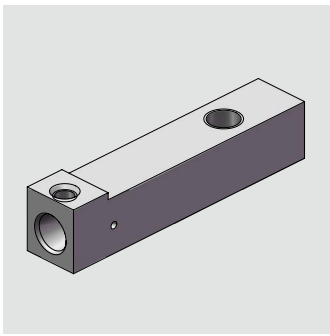

WFMS - statische Halter

WFMS - static holders

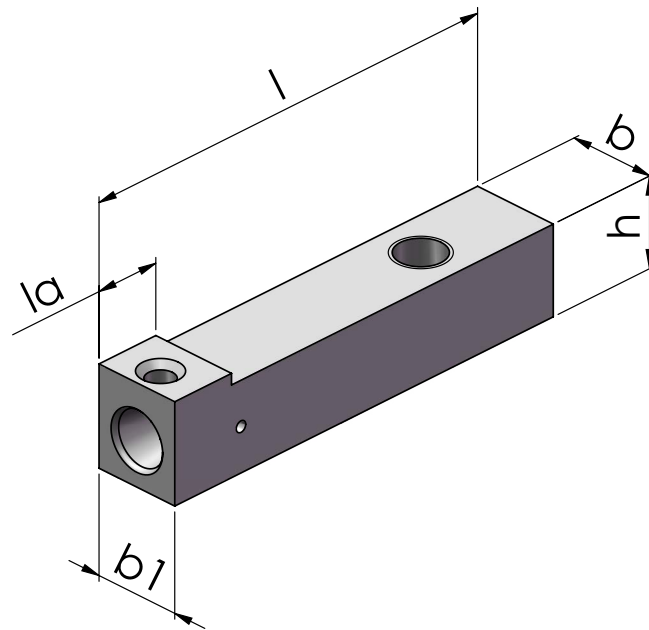







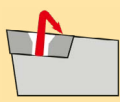

Holder size	[mm]	[mm]	[mm]	[mm]	[mm]	Coolant connection	Order no.
Haltergröße	h	b	l	b1	la	KM-Anschluss	Bestellnummer
3/8"	10,763	9,525	80	12	12	M8x1	WFMS.VKT.009,5.IK
10	11	10	80	12	12	M8x1	WFMS.VKT.010.IK
12	12	12	80	12	12	M8x1	WFMS.VKT.012.IK
12	12	12	65	12	12	M8x1	WFMS.VKT.012.IK.065
1/2"	12,35	12,7	80	12,7	12	M8x1	WFMS.VKT.012,7.IK
5/8"	15,938	15,875	80	15,875	12	G1/8"	WFMS.VKT.015,8.IK
16	16	16	80	16	12	G1/8"	WFMS.VKT.016.IK
16	14	16	65	16	12	G1/8"	WFMS.VKT.016.IK.065

WFMS - modulare Drehhalter ISO Typ Bezeichnungssystem

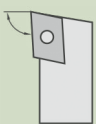
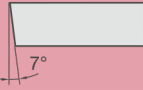
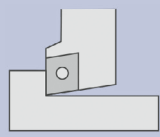
WFMS-modular turning holders
ISO type Designation system

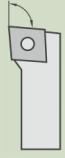
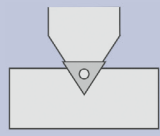

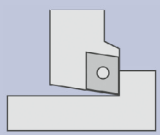
Werkzeugtechnik

Befestigungsart	Wendeplattenform	Klemmhalterform	Wendeplatten-freiwinkel	Schnitt-richtung	Schneidplatten-größe	Kühlung
S  (geschraubt durch Bohrung)	C 80° 	J 93° 	C 	L 	07	IK (Innenkühlung)
	D 55° 	L 95° 		N 	09	
	V 35° 	N 63° 		R 	11	
		V 72,5° 			13	

Produktbeispiel:
WF.M.12.SVJCR.11.IK

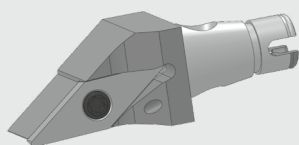

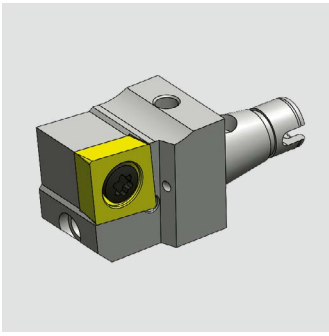

WFMS - modulare Drehhalter ISO C Typ

WFMS - modular turning holders
ISO C type

WG 40

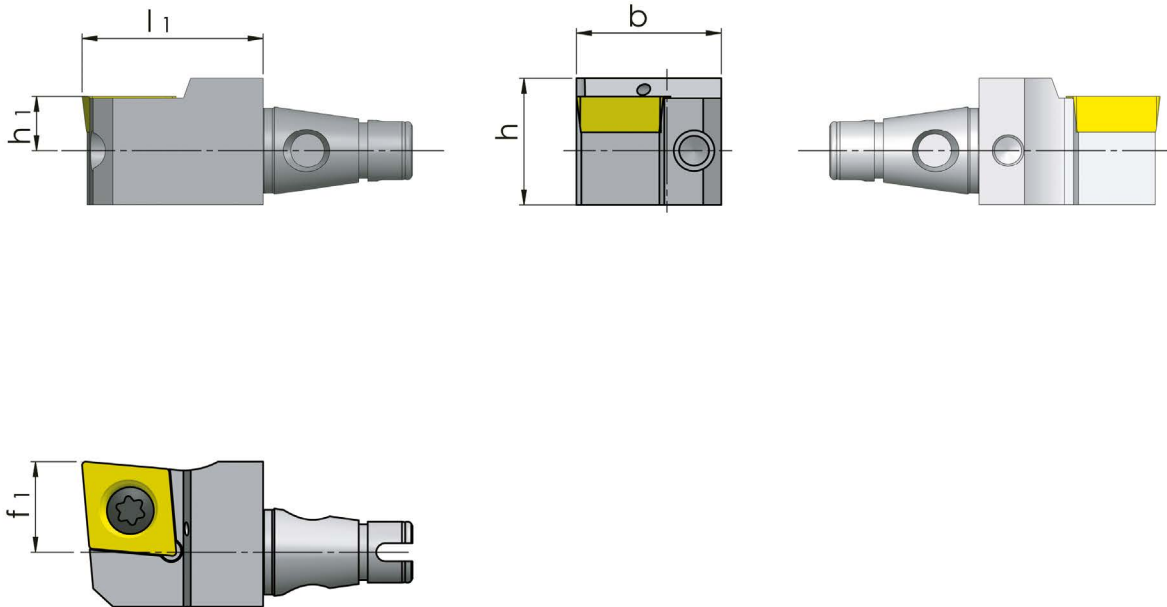

fits for holder	[mm]	[mm]	[mm]	[mm]	[mm]	Order no.
passend für Halter	h	b	l1	h1	f1	Bestellnummer
10x10, 12x12, 1/2"x1/2"	14	16	20	6	6	WF.M.12.SCLCL.09.IK
10x10, 12x12, 1/2"x1/2"	14	16	20	6	6	WF.M.12.SCLCR.09.IK
16x16	20	18	20	8	8	WF.M.16.SCLCL.09.IK
16x16	20	18	20	8	8	WF.M.16.SCLCR.09.IK

WFMS - modulare Drehhalter ISO D Typ

WFMS - modular turning holders
ISO D type

WG 40

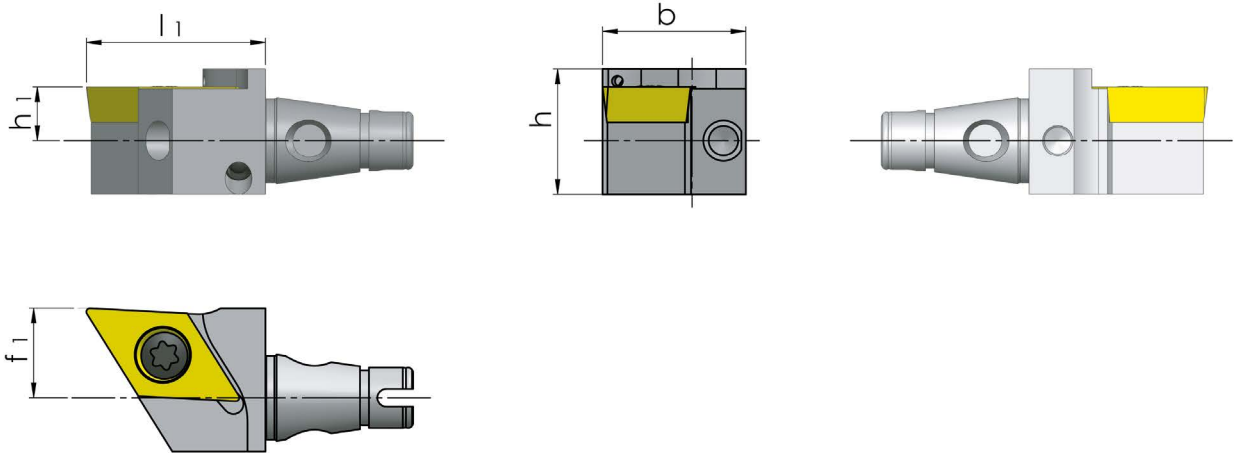
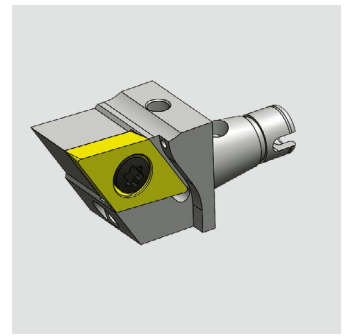

fits for holder	[mm]	[mm]	[mm]	[mm]	[mm]	Order no.
passend für Halter	h	b	l1	h1	f1	Bestellnummer
10x10, 12x12, 1/2"x1/2"	14	16	20	6	6	WF.M.12.SDJCL.11.IK
10x10, 12x12, 1/2"x1/2"	14	16	20	6	6	WF.M.12.SDJCR.11.IK
10x10, 12x12, 1/2"x1/2"	14	16	25	6	0	WF.M.12.SDNCN.11.IK
16x16	18	18	20	8	8	WF.M.16.SDJCL.11.IK
16x16	18	18	20	8	8	WF.M.16.SDJCR.11.IK

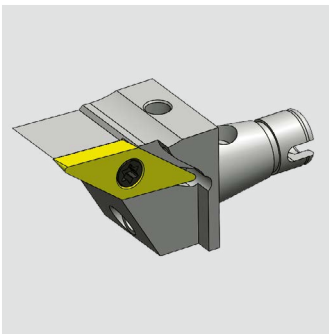

WFMS - modulare Drehhalter ISO V Typ

WFMS - modular turning holders
ISO V type

WG 40

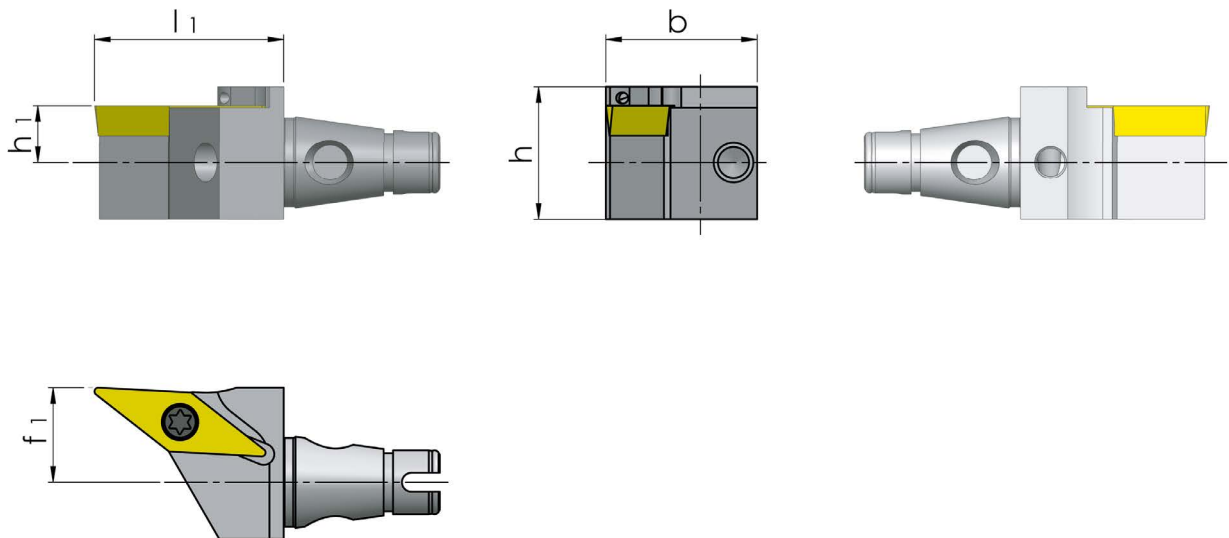

fits for holder	[mm]	[mm]	[mm]	[mm]	[mm]	Order no.
passend für Halter	h	b	l1	h1	f1	Bestellnummer
10x10, 12x12, 1/2"x1/2"	14	16	20	6	6	WF.M.12.SVJCL.11.IK
10x10, 12x12, 1/2"x1/2"	14	16	20	6	6	WF.M.12.SVJCR.11.IK
10x10, 12x12, 1/2"x1/2"	15	16	25	6	0	WF.M.12.SVVCN.11.IK
10x10, 12x12, 1/2"x1/2"	14	16	25	6	10	WF.M.12.SVJCL.13.IK
10x10, 12x12, 1/2"x1/2"	14	16	25	6	6	WF.M.12.SVJCR.13.IK
16x16	18	18	20	8	8	WF.M.16.SVJCL.11.IK
16x16	18	18	20	8	8	WF.M.16.SVJCR.11.IK

WFMS - modulare Drehhalter

WFMS - modular turning holders

WG 40

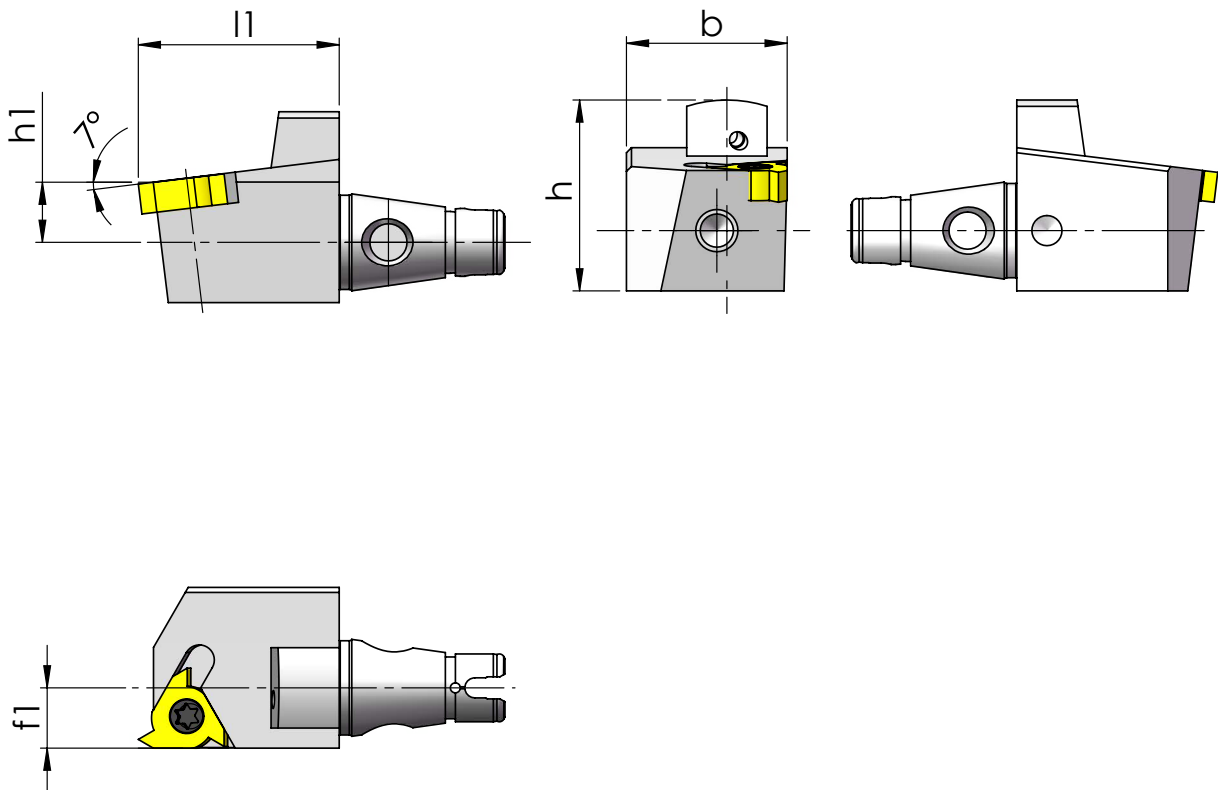
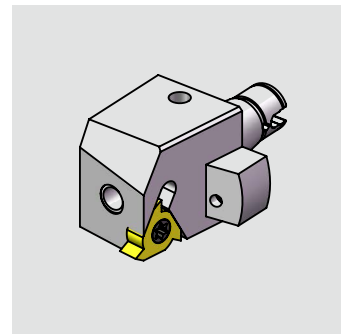

fits for holder	[mm]	[mm]	[mm]	[mm]	[mm]	Order no.
passend für Halter	h	b	l1	h1	f1	Bestellnummer
10x10, 12x12, 1/2"x1/2"	19	16	20	6	6	WF.M.12.11E.IK.R
16x16	22	18	20	8	8	WF.M.16.16E.IK.R

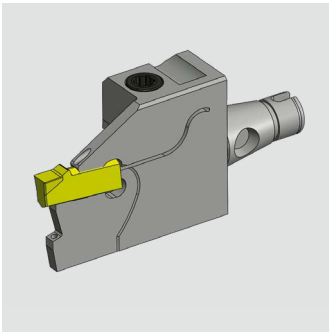

WFMS - modulare Drehhalter Horn H100

WFMS - modular turning holders
Horn H100

WG 40

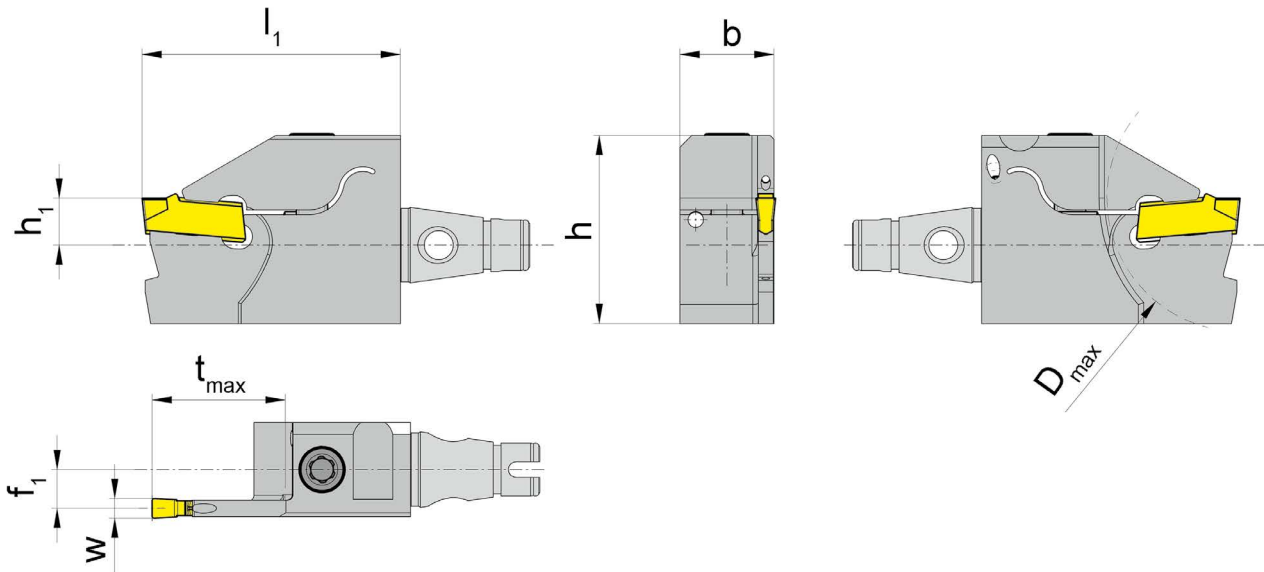

fits for holder	[mm]	[mm]	[mm]	[mm]	[mm]	[mm]	[mm]	[mm]		Order no.
passend für Halter	h	b	l1	h1	f1	tmax	Dmax	w	Größe	Bestellnummer
10x10, 12x12, 1/2"x1/2"	24	12	33	6	5,2	17	34	2	01	WF.M.12.R100.4.41.IK
10x10, 12x12, 1/2"x1/2"	24	12	33	6	4,95	17	34	2,5	02	WF.M.12.R100.4.42.IK
10x10, 12x12, 1/2"x1/2"	24	12	33	6	4,75	17	34	3	03	WF.M.12.R100.4.43.IK
16x16	26	16	33	8	7,2	17	34	2	01	WF.M.16.R100.4.41.IK
16x16	26	16	33	8	6,95	17	34	2,5	02	WF.M.16.R100.4.42.IK
16x16	26	16	33	8	6,75	17	34	3	03	WF.M.16.R100.4.43.IK

Spare Parts

Ersatzteile

Screw Spannschraube	Clamp Spannelement	TORX PLUS Wrench TORX PLUS-Schlüssel	For torque specification Nm Das Anzugsmoment der Schrauben ist Nm.	Toolholder Klemhalter
4.20T15P		T15PL	4,3	WF.M.1...R100...IK

WFMS - modulare Drehhalter Horn H224

WFMS - modular turning holders
Horn H224

WG 40

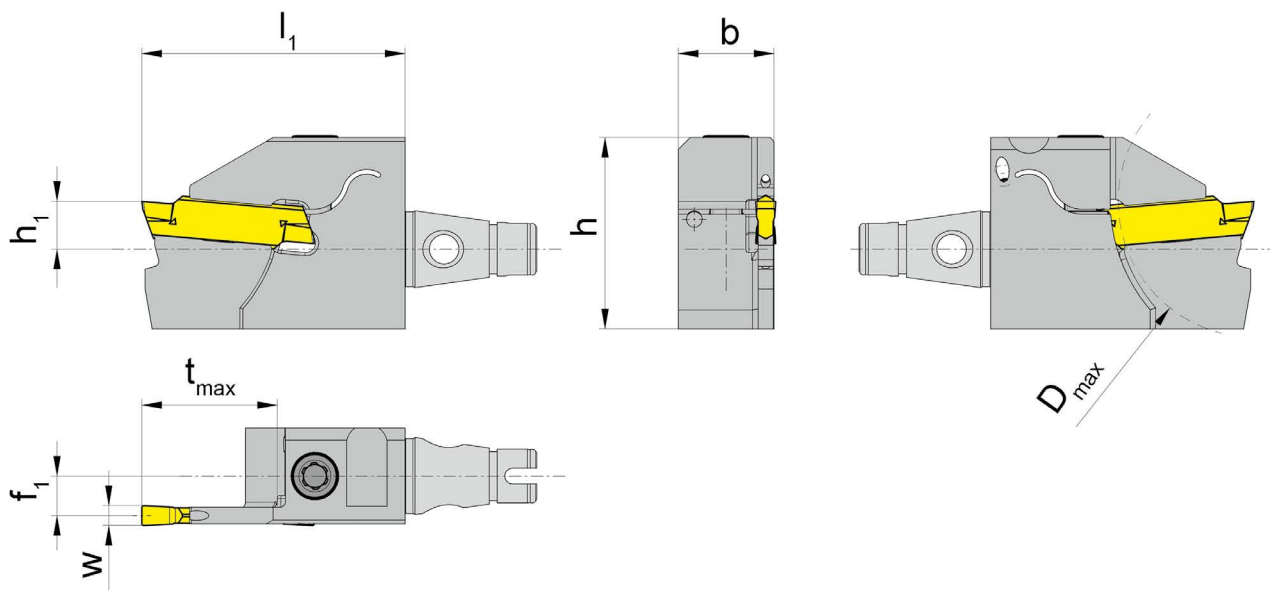
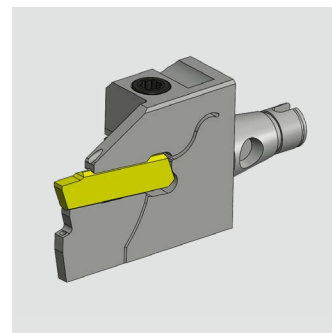

fits for holder	[mm]	[mm]	[mm]	[mm]	[mm]	[mm]	[mm]	[mm]	[mm]	Order no.
passend für Halter	h	b	l1	h1	f1	tmax	Dmax	w	Größe	Bestellnummer
10x10, 12x12, 1/2"x1/2"	24	12	33	6	5,2	17	34	2	01	WF.M.12.R224.4.41.IK
10x10, 12x12, 1/2"x1/2"	24	12	33	6	4,95	17	34	2,5	02	WF.M.12.R224.4.42.IK
10x10, 12x12, 1/2"x1/2"	24	12	33	6	4,75	17	34	3	03	WF.M.12.R224.4.43.IK
16x16	26	16	33	8	7,2	17	34	2	01	WF.M.16.R224.4.41.IK
16x16	26	16	33	8	6,95	17	34	2,5	02	WF.M.16.R224.4.42.IK
16x16	26	16	33	8	6,75	17	34	3	03	WF.M.16.R224.4.43.IK

Spare Parts

Ersatzteile

Screw Spannschraube	Clamp Spannelement	TORX PLUS Wrench TORX PLUS-Schlüssel	For torque specification Nm Das Anzugsmoment der Schrauben ist Nm.	Toolholder Klemhalter
4.20T15P		T15PL	4,3	WF.M.1...R224...IK

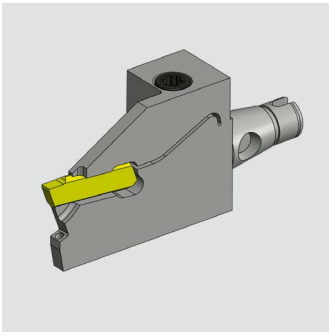

WFMS - modulare Drehhalter Horn H264

WFMS - modular turning holders
Horn H264

WG 40

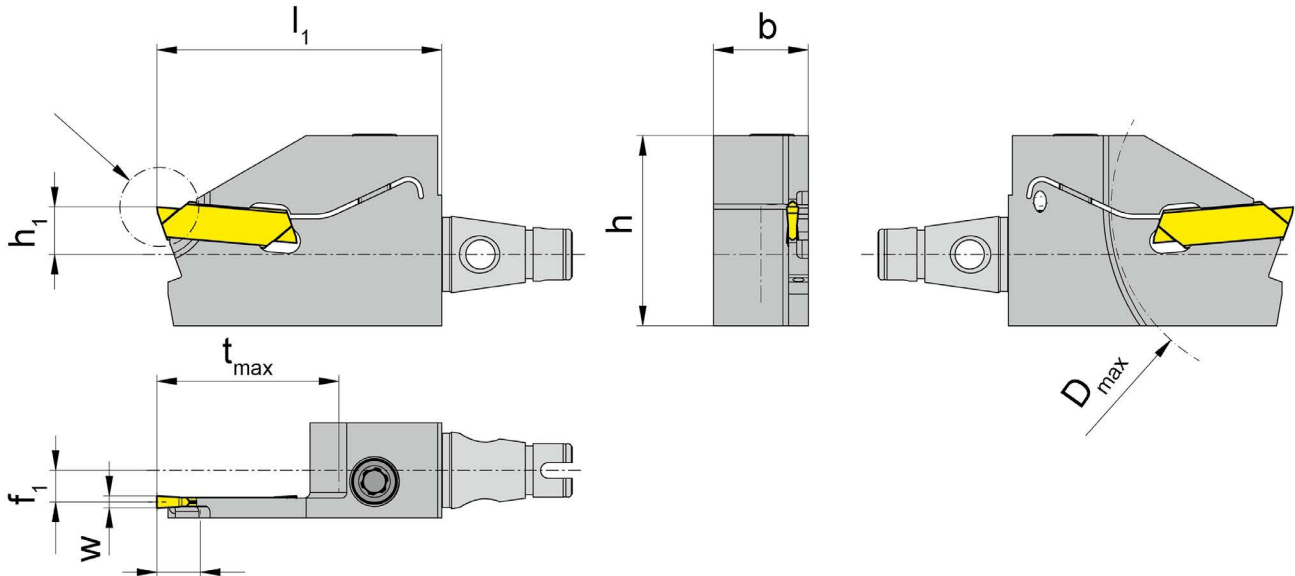

fits for holder	[mm]	[mm]	[mm]	[mm]	[mm]	[mm]	[mm]	[mm]		Order no.
passend für Halter	h	b	l1	h1	f1	tmax	Dmax	w	Größe	Bestellnummer
10x10, 12x12, 1/2"x1/2"	24	12	36	6	4	5,5	10	1,5	01	WF.M.12.R264.1.51.IK
16x16	23	16	36	8	6	5,5	10	1,5	01	WF.M.16.R264.1.51.IK

Spare Parts

Ersatzteile

Screw Spannschraube	Clamp Spannelement	TORX PLUS Wrench TORX PLUS-Schlüssel	For torque specification Nm Das Anzugsmoment der Schrauben ist Nm.	Toolholder Klemmhalter
4.20T15P		T15PL	4,3	WF.M.1...R264.1.51.IK

WFMS - modulare Drehhalter Horn H274

WFMS - modular turning holders
Horn H274

WG 40

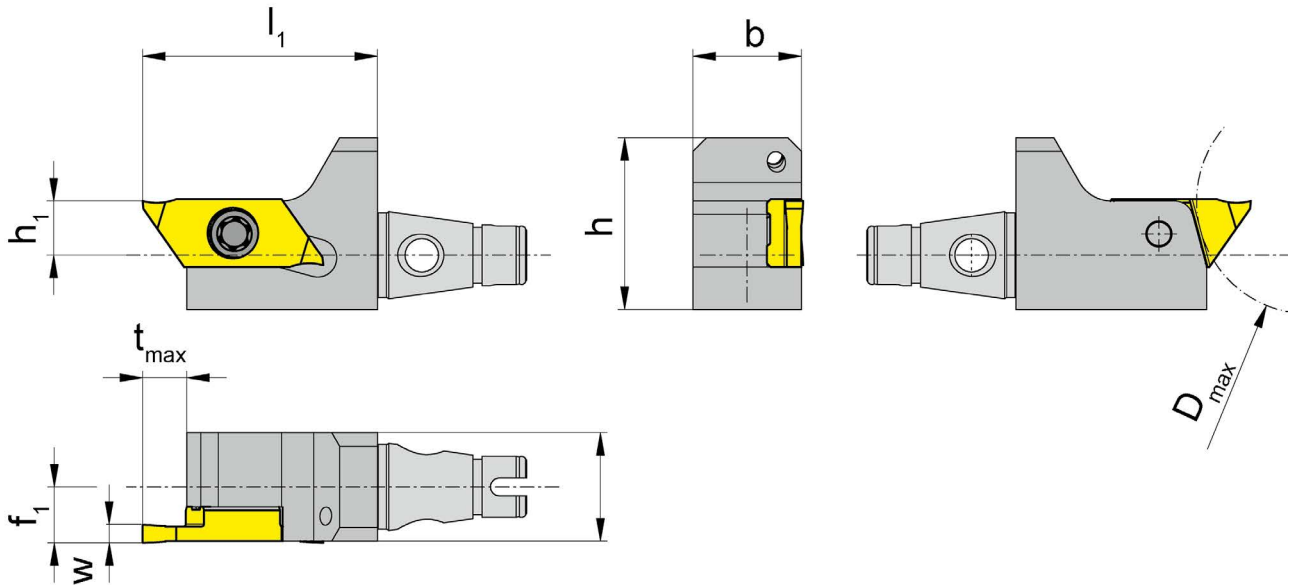
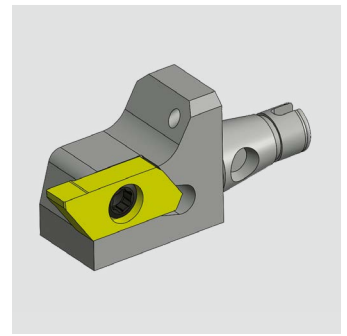

fits for holder	[mm]	[mm]	[mm]	[mm]	[mm]	[mm]	[mm]	[mm]	[mm]	Order no.
passend für Halter	h	b	l1	h1	f1	tmax	Dmax	w	Größe	Bestellnummer
10x10, 12x12, 1/2"x1/2"	19	12	26	6	6,2	6	25	04	01	WF.M.12.R274.2.24.IK
16x16	23	16	26	8	8,2	6	25	04	02	WF.M.16.R274.2.24.IK

Spare Parts

Ersatzteile

Screw	Clamp	TORX PLUS Wrench	For torque specification Nm	Toolholder
Spannschraube	Spannelement	TORX PLUS-Schlüssel	Das Anzugsmoment der Schrauben ist Nm.	Klemmhalter
030.3509.T15P		T15PQ	3,0	WF.M.1...R274.2.24.IK

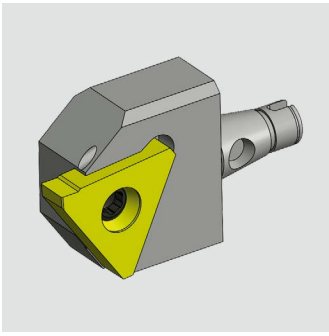

WFMS - modulare Drehhalter Horn H356

WFMS - modular turning holders
Horn H356

WG 40

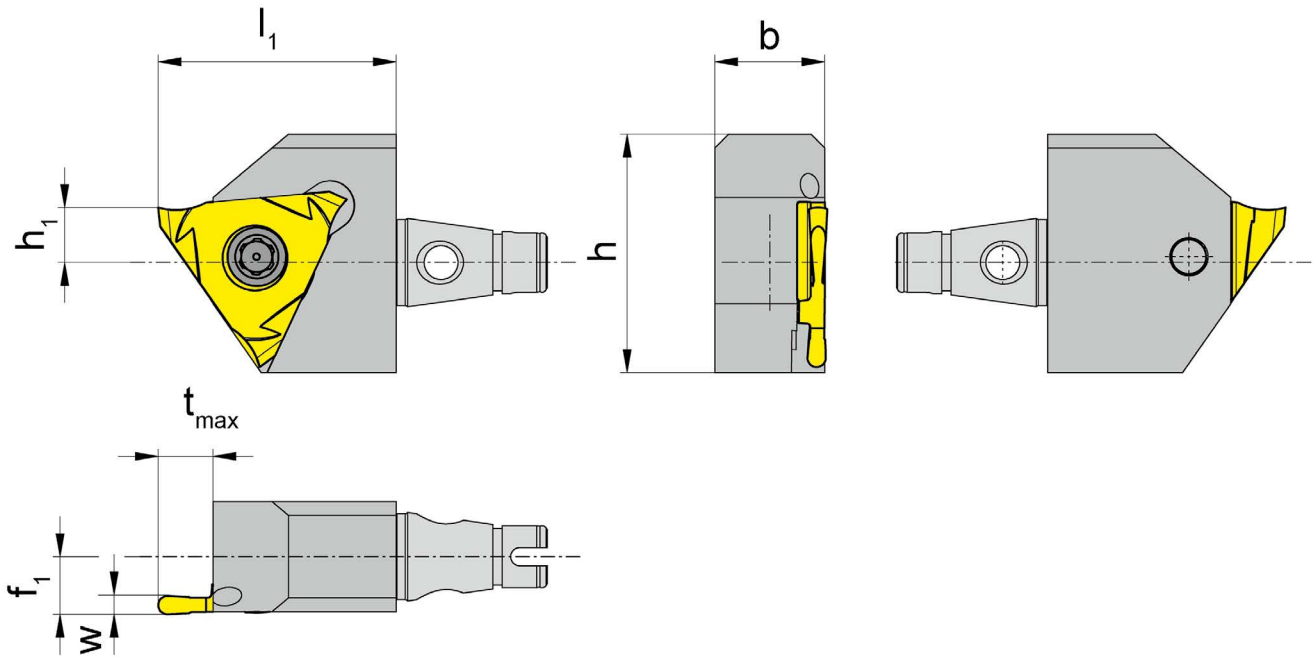

fits for holder	[mm]	[mm]	[mm]	[mm]	[mm]		Order no.
passend für Halter	h	b	l1	h1	f1	Größe	Bestellnummer
10x10, 12x12, 1/2"x1/2"	26	12	26	6	6,3	03	WF.M.12.R356.1.23.IK
16x16	26	16	26	8	8,3	03	WF.M.16.R356.1.23.IK

Spare Parts

Ersatzteile

Screw Spannschraube	Clamp Spannelement	TORX PLUS Wrench TORX PLUS-Schlüssel	For torque specification Nm Das Anzugsmoment der Schrauben ist Nm.	Toolholder Klemmhalter
030.500P.0232		T20PQ	6,0 - 6,5	WF.M.12.R356.1.23.IK
5.12T20P		T20PQ	6,0 - 6,5	WF.M.16.R356.1.23.IK

WFMS - modulare Drehhalter Horn H360

WFMS - modular turning holders
Horn H360

WG 40

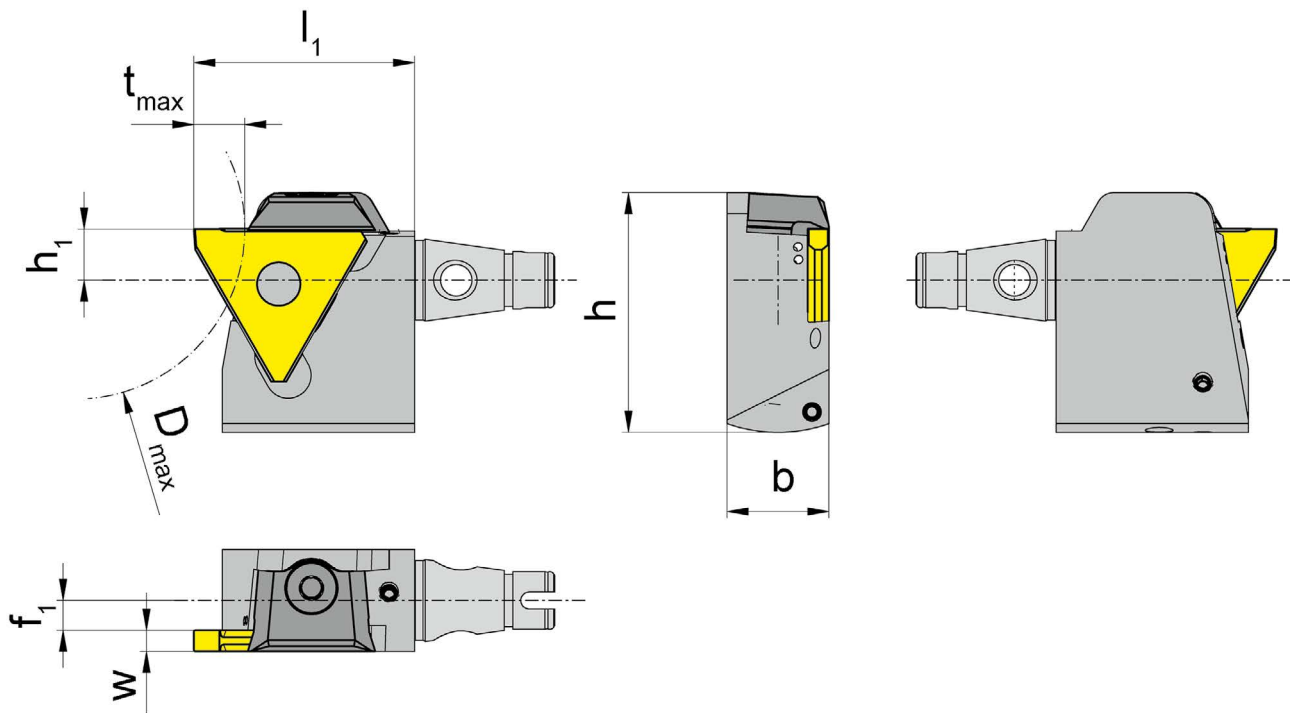
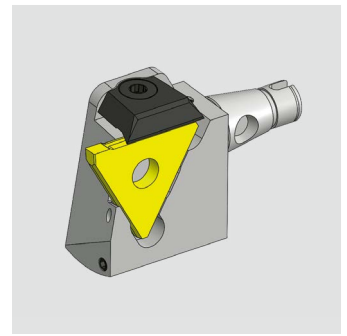

fits for holder	[mm]	[mm]	[mm]	[mm]	[mm]	[mm]	[mm]	[mm]		Order no.
passend für Halter	h	b	l1	h1	f1	tmax	Dmax	w	Größe	Bestellnummer
10x10, 12x12, 1/2"x1/2"	28,2	12	26	6	4,5	4	40	0,5 - 1,9	01	WF.M.12.R360.1.51.IK
10x10, 12x12, 1/2"x1/2"	28,2	12	26	6	3,5	6	40	1,9 - 2,9	02	WF.M.12.R360.2.52.IK
10x10, 12x12, 1/2"x1/2"	28,2	12	26	6	2,5	6	40	2,9 - 3,9	03	WF.M.12.R360.2.53.IK
16x16	30,2	16	26	8	6,5	4	40	0,5 - 1,9	01	WF.M.16.R360.1.51.IK
16x16	30,2	16	26	8	5,5	6	40	1,9 - 2,9	02	WF.M.16.R360.2.52.IK
16x16	30,2	16	26	8	4,5	6	40	2,9 - 3,9	03	WF.M.16.R360.2.53.IK

Spare Parts

Ersatzteile

Screw Spannschraube	Clamp Spannelement	TORX PLUS Wrench TORX PLUS-Schlüssel	For torque specification Nm Das Anzugsmoment der Schrauben ist Nm.	Toolholder Klemmhalter
12.3		T10PL	3,0	WF.M.1...R360...IK

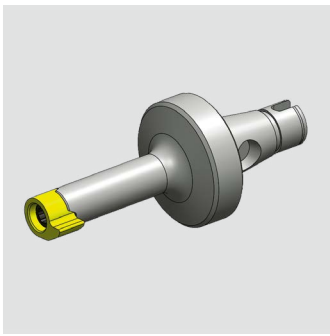

WFMS - modulare Drehhalter Horn Mini 106 - 11P

WFMS - modular turning holders
Horn Mini 106 - 11P

WG 40

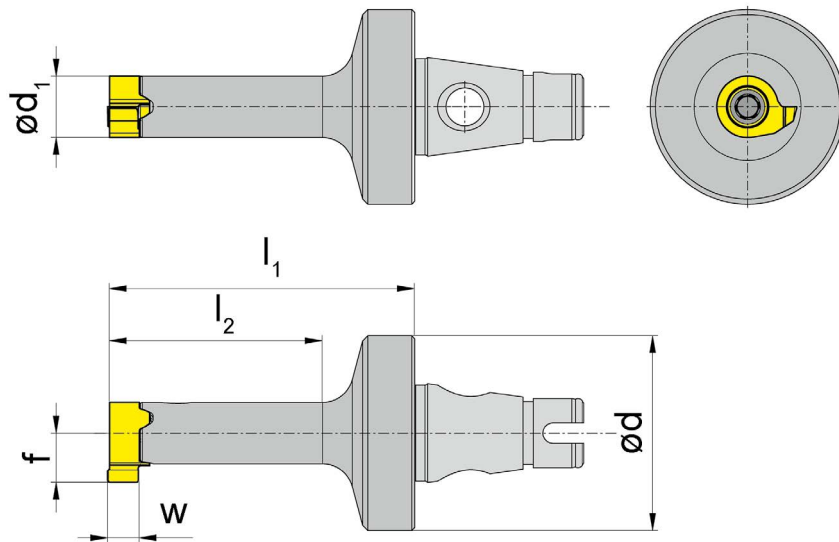

fits for holder	[mm]	[mm]	[mm]	[mm]	Order no.
passend für Halter	d	d1	l1	l2	Bestellnummer
Ø 19,05-28	19	4,4	17	8,5	WF.M.RB106.00.IK
Ø 19,05-28	19	5,2	19	10	WF.M.RB107.00.IK
Ø 19,05-28	19	6	21,5	12,5	WF.M.B108.00.IK
Ø 19,05-28	19	6	30	21	WF.M.B108.01.IK
Ø 19,05-28	19	6	21	12,5	WF.M.RB10P.00.IK
Ø 19,05-28	19	8	26	16,5	WF.M.B111.00.IK
Ø 19,05-28	19	8	38,5	29	WF.M.B111.01.IK
Ø 19,05-28	19	7	24	15	WF.M.RB11P.00.IK

Spare Parts

Ersatzteile

Screw	Clamp	TORX PLUS Wrench	For torque specification Nm	Toolholder
Spannschraube	Spannelement	TORX PLUS-Schlüssel	Das Anzugsmoment der Schrauben ist Nm.	Klemmhalter
1.8.4TEP		T6PL	0,9	WF.M.RB106.00.IK
2.2.5T7EP	010.0105.03	T7PL	1,1	WF.M.RB107.00.IK
2.6.5T8EP	010.0105.04	T8PL	1,2	WF.M.B108.00.IK / ..B10P./..
3.5.12T10EP	010.0105.05	T10PL	3	WF.M.B111.00.IK
3.10T9P		T9PL	1,8	WF.M.RB11P.00.IK

WFMS - modulare Drehhalter Horn Supermini 105-110

WFMS - modular turning holders
Horn Supermini 105-110

WG 40

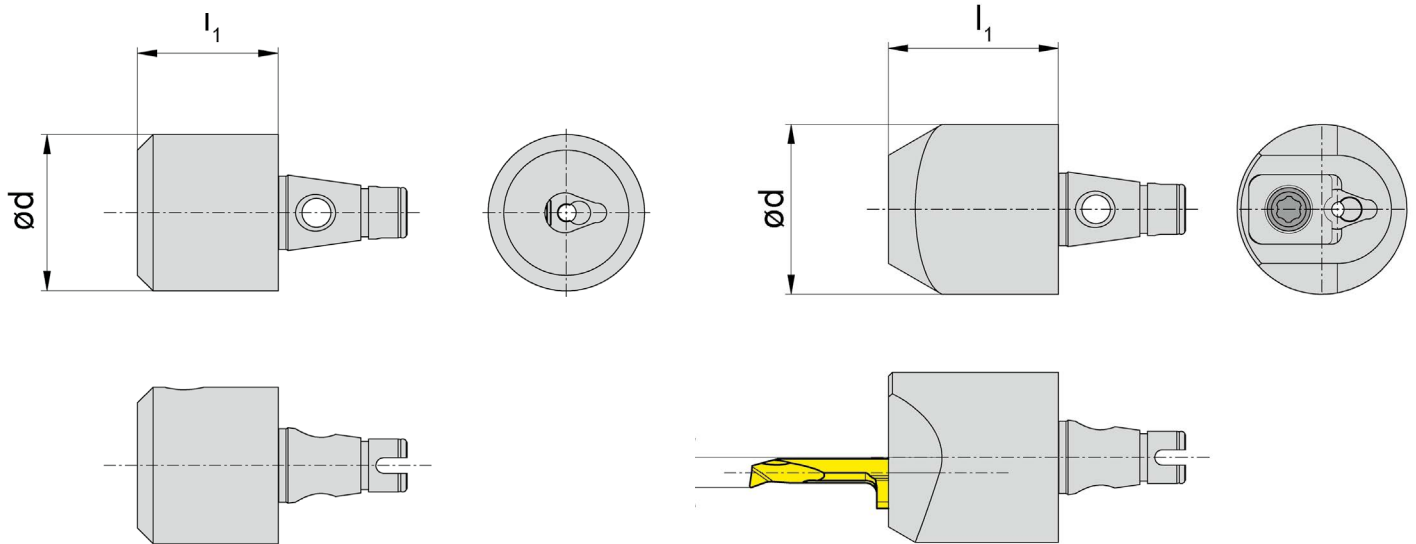

fits for holder	[mm]	[mm]	[mm]	[mm]	Order no.
passend für Halter	d	l1	f1	*b	Bestellnummer
Ø 19,05-28	20	18	-	-	WF.M.B105.IK
Ø 19,05-28	22	30	-	-	WF.M.B110.IK
Ø 19,05-28	22	22	3,3	5,9	WF.M.B105.S.03.IK
Ø 19,05-28	22	22	3,9	6,4	WF.M.B105.S.04.IK
Ø 19,05-28	21	22	5,3	7,0	WF.M.B105.S.05.IK

*b = Schneidplattenhöhe

*b = Height of insert

Spare Parts

Ersatzteile

Screw	Clamp	TORX PLUS Wrench	For torque specification Nm	Toolholder
Spannschraube	Spannelement	TORX PLUS-Schlüssel	Das Anzugsmoment der Schrauben ist Nm.	Klemmhalter
6.075T15P		T15PQ	5	WF.M.B105.IK / WF.M.B110.IK
	010.0105.03	T15PL	2	WF.M.B105.S.03.IK
	010.0105.04	T15PL	2	WF.M.B105.S.04.IK
	010.0105.05	T15PL	2	WF.M.B105.S.05.IK

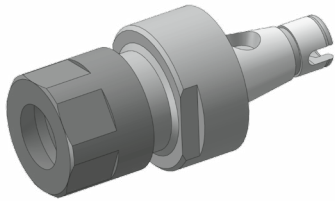

Drehhalter Typ ER11

Turning holder type ER11

Bestellnummer WFMS.E11.025.M

Order no.

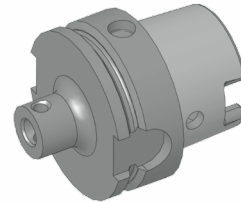

Drehhalter Grundhalter HSK63

Turning holder basic holder HSK63

Bestellnummer WFMS.020.H63

Order no.

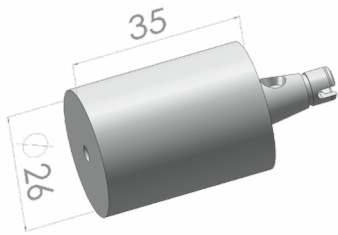

Drehhalter Rohling Ø 26

Turning holder blank Ø 26

Bestellnummer WFMS.R.D26x35

Order no.

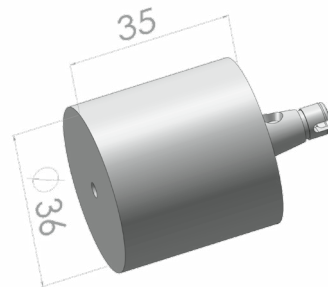

Drehhalter Rohling Ø 36

Turning holder blank Ø 36

Bestellnummer WFMS.R.D36x35

Order no.

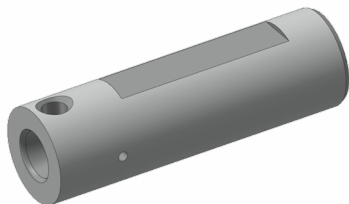

Drehhalter Rundschaft

Turning holder cylindrical

Bestellnummer WFMS.RS.20.065.IK

Order no.

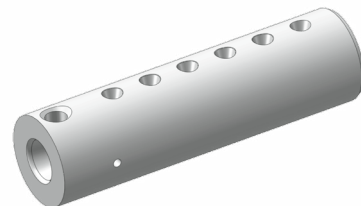

Drehhalter Rundschaft

Turning holder cylindrical

Bestellnummer WFMS.RS.22.080.IK

Order no.

THE EVOLUTION WF-MICRO System for DECO 10

driven and static toolholders

WF
&

Werkzeugtechnik

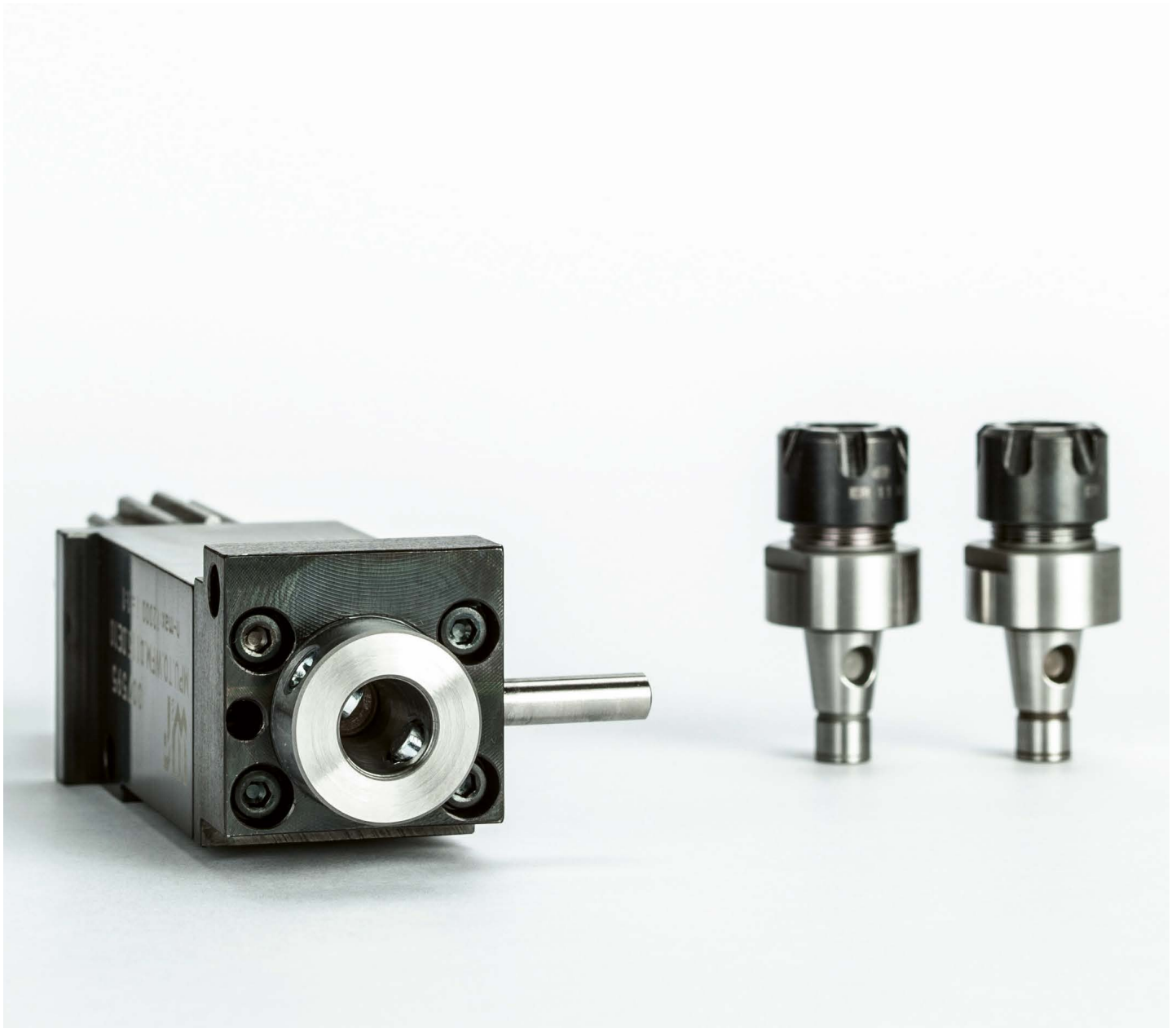

**Minimize the costs of cutting tools
and increase productivity**

- quick change
- presetting outside of machine
- highest runout

Modulare Aggregatetechnik

WFB ADAPTER

WF
&

Werkzeugtechnik



**Katalog
WFB-02**



Werkzeugtechnik

Inhaltsverzeichnis für WFB-Adapter

Table of contents for WFB-adapter
Table des matières pour WFB-adapteur

Beschreibung / Description	Seite / Page
WFB - Aufsatz WFB top piece	11.2
Gebrauch und Wartung der WFB-Schnittstelle Handling and maintenance for WFB connection Manutention et maintenance pour WFB connexion	11.3
Produkt-Vorteile der WFB-Schnittstelle Product advantages of WFB connection	11.4-11.5
WFB - Produktübersicht (Auszug) WFB - Product overview WFB - Vue d'ensemble de produit	11.6-11.7
WFB - Grundaufnahmen / Voreinstelladapter WFB - Master shanks WFB - Module de base	11.8-11.9
WFB - Weldon für Zylinderschäfte DIN 1835 B WFB - Weldon for parallel shanks WFB - Weldon pour queues cylindriques	11.10-11.11
WFB - WN für Zylinderschäfte DIN 1835 E WFB - Whistle Notch for parallel shanks WFB - Whistle Notch pour queues cylindriques	11.12-11.13
WFB - Schrumpffutter WFB - Shrink fit chucks WFB - Mandrins de frettage	11.14-11.15
Bedienungsanleitung für zweigeteilte Schrumpffutter System WFB Operation instructions for two split shrink fit chucks system WFB Mode d'emploi pour deux divisé mandrins de frettage système WFB	11.16
WFB - Sägeblattaufnahmen WFB - Tool holders for saw blade WFB - Mandrins pour lame de scie	11.17
WFB - Spannzangenfutter 8° Typ ER WFB - Collet chucks 8° type ER WFB - Mandrins porte-pinces 8° type ER	11.18-11.19
WFB - Softsynchro® mit IKZ WFB - Softsynchro® with internal cooling system WFB - Softsynchro® avec arrosage central	11.20
WFB - Hydro-Dehnspannfutter WFB - Hydraulic expansion chuck WFB - Mandrin hydraulique	11.21
WFB-Drehhalter W-T mit IKZ WFB - Turning tool holder W-T with internal cooling system WFB - Rotatif porte-outil W-T avec arrosage central	11.22
WFB-Klemmhalter W-T HORN Mini mit IKZ WFB - Toolholder W-T HORN Mini with internal cooling system WFB - Porte-outil W-T HORN Mini avec arrosage central	11.23

Inhaltsverzeichnis für WFB-Adapter

Table of contents for WFB-adapter
Table des matières pour WFB-adapteur



Werkzeugtechnik

Beschreibung / Description	Seite / Page
WFB-Klemmhalter W-T HORN Supermini® mit IKZ WFB - Toolholder W-T HORN Supermini® with internal cooling system WFB - Porte-outil W-T HORN Supermini® avec arrosage central	11.24
WFB - Horn Fräserschaft mit IKZ WFB - Horn milling shank with internal cooling WFB - Horn arbre de coupe avec arrosage central	11.25
WFB-Bohrstangenhalter WFB - Boring bar holder WFB - Porte-outil pour barres d'alésage	11.26
WFB - Aufsteckfräserdorne mit IKZ WFB - Milling machine arbors with internal cooling system WFB - Mandrins porte-fraises avec arrosage central	11.27
WFB - Verschlussstopfen WFB - Closing plug WFB - Bouchon d'étanchéité	11.28
WFB - Reduzierungen / Verlängerungen WFB - Reductions / Extensions WFB - Réductions / Prolongations	11.29
WFB - Kontrolldorne WFB - Test arbors WFB - Mandrins de contrôle	11.30
WFB - Bohrstangen-Rohlinge WFB - Boring bar-blanks WFB - Barres à l'état brut	11.31
Spannzangen-Sätze mit Holzsockel System ER / ESX Collets System ER / ESX in wooden board Pincés de serrage Système ER / ESX en socle de bois	11.33
Spannzangen System ER / ESX ER11 / ER16 / ER20 Collets System ER / ESX Pincés de serrage Système ER / ESX	11.34
Spannzangen System ER / ESX ER25 / ER32 / ER40 Collets System ER / ESX Pincés de serrage Système ER / ESX	11.35
WFB - Ersatzteile / Zubehör WFB - Spare parts / Accessories WFB - Pièces de rechange / Accessoires	11.36

WG = Warengruppe
Article group
Groupe de marchandise

WG 11 = _____

WG 35 = _____



Adapter >>GA<<



Vorsatzhalter Gr.I
Tool post size I



Adapter SK50



WFB-Adapter

Der WFB-Adapter wird über 2 Kegelgewindestifte im WFB-Aufsatz fixiert und ist somit optimal positioniert.
The WFB-Adapter will be fixed in the WFB top piece via 2 threaded taper pins and is thus optimally positioned.

Durch die 100%-ige Einstellbarkeit der Adaptersysteme auf einem ZOLLER Einstell- und Messgerät reduziert sich die Maschinenrüstzeit nahezu gegen null. Teurer Maschinenstillstand kann somit vermieden werden.
Thanks to the excellent adjustability of the adapter systems on ZOLLER tool presetter and measuring machines setup times are reduced towards zero thus avoiding expensive machine downtimes.

- ✓ Hohe Wechselgenauigkeiten (<math><2\mu</math>) und absoluter Formschluss
High changing accuracy (<math><2\mu</math>) and absolute form fit
- ✓ Optimale Kraftübertragung und Steifigkeit durch kompakten Aufbau
Optimum power transmission and rigidity thanks to a compact assembly
- ✓ Flexible Anwendungsmöglichkeiten, wie z. B. Spannzangenfutter, Weldon, Schrumpffutter u. v. a. m.
Flexible application spectrum, e.g. collet chucks, weldon, shrink fit chucks and others
- ✓ Für angetriebene oder feststehende Werkzeuge geeignet
Suitable for driven or stationary tools
- ✓ Einsetzbar in Dreh- und Fräsmaschinen und Bearbeitungszentren
To be used in turning and milling machines and machining centres
- ✓ Einfacher und günstiger Spannmechanismus durch 2 Kegelgewindestifte
Simple and convenient clamping mechanism via 2 threaded taper pins
- ✓ Geringe Rüstzeiten
Reduced setup times
- ✓ Modular aufgebautes System, keine aufwändigen Sonderwerkzeughalter notwendig
Modular designed system, no complex tool holders required

WFB top piece	Adapter >>GA<<	Vorsatzhalter Gr.I / Tool post size I	Adapter SK50 / ISO 50
WFB-Aufsatz	Art.-Nr. / Item no.	Art.-Nr. / Item no.	Art.-Nr. / Item no.

WFB20-12	WFB.6120.Y50	WFB.6020.Y50	WFB.6320.Y50
WFB24-16	WFB.6121.Y50	WFB.6021.Y50	WFB.6321.Y50
WFB32-20	WFB.6122.Y50	WFB.6022.Y50	WFB.6322.Y50
WFB40-25	WFB.6123.Y50	WFB.6023.Y50	WFB.6323.Y50
WFB50-32	WFB.6124.Y50	WFB.6024.Y50	WFB.6324.Y50

Gebrauch und Wartung der WFB-Schnittstelle

Handling and maintenance for WFB connection
Manutention et maintenance pour WFB connexion

WG 35



Werkzeugtechnik

Hinweis zur Befestigung

Zunächst einen Kegelnstift anziehen, dabei 1-2 mal lösen und wieder anziehen. Dadurch wird eine optimale Positionierung der Bauteile erreicht. Der 2. Kegelnstift wird nun ebenfalls (wie oben angeführt) angezogen. Empfohlene Drehmomente entnehmen Sie der unteren Tabelle.

Advice for fixing

First tighten one threaded taper pin, in doing so 1 or 2 times unscrew and tighten again. Thereby you get an optimum positioning of the components. The second threaded taper pin you will tighten with the same method. Recommended locking torque see in the lower table.

Pflege und Wartung

Die Oberflächen der Planflächen, der Kegelnbohrung und Kegelnzapfen sind vor Gebrauch zu reinigen und mit einem Öl-Schmierfilm zu versehen. Um eine optimale Befestigung und Lösbarkeit der Kegelnstifte zu erreichen, wird empfohlen die Kegelnstifte mit z.B. Molykote 1000 oder einer ähnlichen Heiss-Schraubenpaste zu behandeln.

Support and maintenance

The surface of the face, the cone drill and cone pin must be cleaning and lubricate with oil before using. To reach an optimum fixing and resolvability of the threaded taper pins, are recommended to use for example Molykote 1000 or something similar.

Empfohlene Anzugsdrehmomente

Recommended locking torque / Retenue couple

Größe	Kegelnstifte	Anzugs-Drehmoment
WFB20-12	M6 x 0,75 / Torx 15 Plus	4 Nm
WFB20-12	M6 x 1 / Torx T15	4 Nm
WFB24-16	M8 x 1 / Torx T25	10 Nm
WFB32-20	M10 x 1	20 Nm

Empfohlene Anzugsdrehmomente beim Einsatz von Kontrolldornen

Recommended locking torque when running test arbors

Retenue couple à l'usage de Mandrins de contrôle

Größe	Kegelnstifte	Anzugs-Drehmoment
WFB20-12	M6 x 0,75 / Torx 15 Plus	2 Nm
WFB20-12	M6 x 1 / Torx T15	2 Nm
WFB24-16	M8 x 1 / Torx T25	5 Nm
WFB32-20	M10 x 1	10 Nm

Vorteile auf einen Blick:

Wirtschaftlich

Durch den Einsatz von Werkzeugen, die parallel zur Maschinenlaufzeit voreingestellt werden, reduziert sich die Maschinenrüstzeit nahezu auf Null. Teure Maschinenstillstandzeiten werden vermieden.

Präzise

Die Kegel/Plananlage mit zylindrischer Abstützung gewährleistet höchste Genauigkeit und absoluten Formschluß.

Bedienerfreundlich

- Keine Verletzung der Hände.
- Kein Risiko, die Werkzeuglager durch das Einschrauben von Spannfuttern zu beschädigen.
- Geringes Risiko, den teuren Werkzeughalter beim Ein- und Ausbau zu beschädigen.
- Präzise Werkzeugvoreinstellung außerhalb der Maschine.
- Genaues und wiederholbares Spannen des Adapters mit definiertem Drehmoment.

Flexibel

- Verwendung unterschiedlicher Spanntechnologien auf einem gleichbleibenden Halter.
- Für jeden Bearbeitungsvorgang lässt sich das optimale Spannsystem anwenden.
- Weniger unterschiedliche angetriebene Werkzeuge von Nöten.
- Adapter auf angetriebenen und auch auf statischen Werkzeugen einsetzbar.

Merkmale der WFB-Schnittstelle

- große Plananlage bildet zusammen mit Kegelmantel Formschluss.
- stabiler „Vollkegel-Mantel“ sorgt für enorme Steifigkeit.
- Abstützbund verhindert Axialbewegung des Kegels bei Radialbelastungen.
- zylindrischer Absatz zur Unterbringung des Spannsystems.
- sicherer und einfacher Spannsystem durch zwei spezielle Kegelgewindestifte.
- Stellgewinde zur Einstellung der Werkzeuglänge.
- Adapter dank Kühlmittelbohrung bereit für die Verwendung mit Innenkühlung.

WFB

Hochpräzisions-Schnellwechselsystem für Drehmaschinen



Besuchen Sie uns



W&F Werkzeugtechnik GmbH

Kantstr. 4
72663 Großbottlingen
Deutschland

info@wf-werkzeugtechnik.de
www.wf-werkzeugtechnik.de

Product- advantages of WFB-Connection

WG 35

W&F

Werkzeugtechnik

The advantages at a glance:

Economical

By using tools that are preset parallel to the machine running time, the machine set-up time is reduced to almost zero. Expensive machine downtimes are avoided.

Precise

The cone/face contact with cylindrical support ensures the highest level of accuracy and an absolute form fit.

User friendly

- no injury to hands.
- no risk of damaging tool bearings by screwing in chucks.
- low risk of damaging the expensive tool holder during installation and removal.
- precise tool presetting outside the machine.
- accurate and repeatable clamping of the adapter with defined torque.

Flexible

- use of different clamping technologies on one consistent holder.
- the optimum clamping system can be selected for every machining process.
- fewer different power tools required.
- adapters on driven and also on static tools usable.

Features of the WFB interface

- large flat contact forms a form fit together with the cone shell.
- stable "full cone jacket" ensures enormous rigidity.
- support collar prevents axial movement of the cone under radial loads.
- cylindrical shoulder to accommodate the tensioning mechanism.
- safe and simple clamping mechanism thanks to two special taper thread pins.
- adjusting thread for setting the tool length.
- adapter ready for use with internal cooling thanks to coolant hole.

WFB

high-precision quick-change system for swiss-type machines



visit us



W&F Werkzeugtechnik GmbH

Kantstr. 4
72663 Großbettlingen
Germany

info@wf-werkzeugtechnik.de
www.wf-werkzeugtechnik.de

WFB - Produktübersicht (Auszug)

WFB - Product overview
WFB - Vue d'ensemble de produit

WG 35**WFB - Aggregate**

WFB - Aggregates

WFB - Agrégats

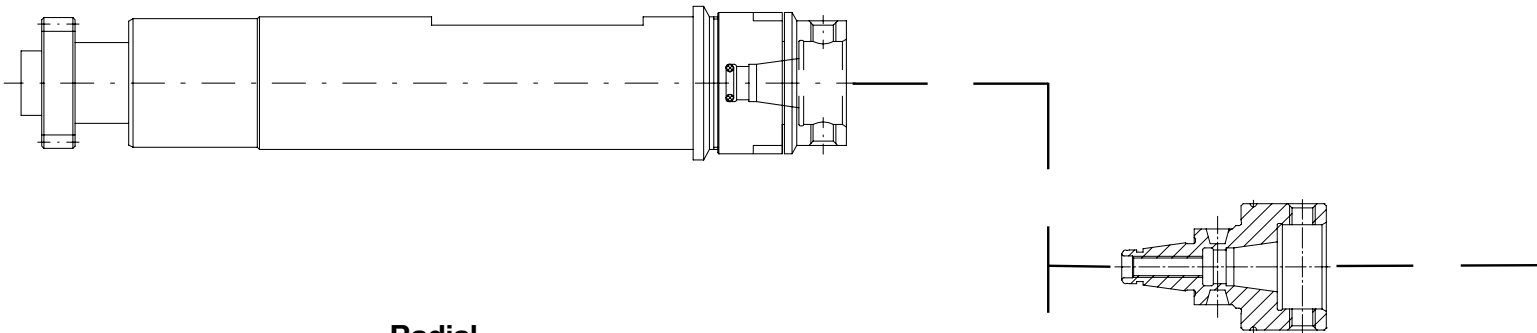
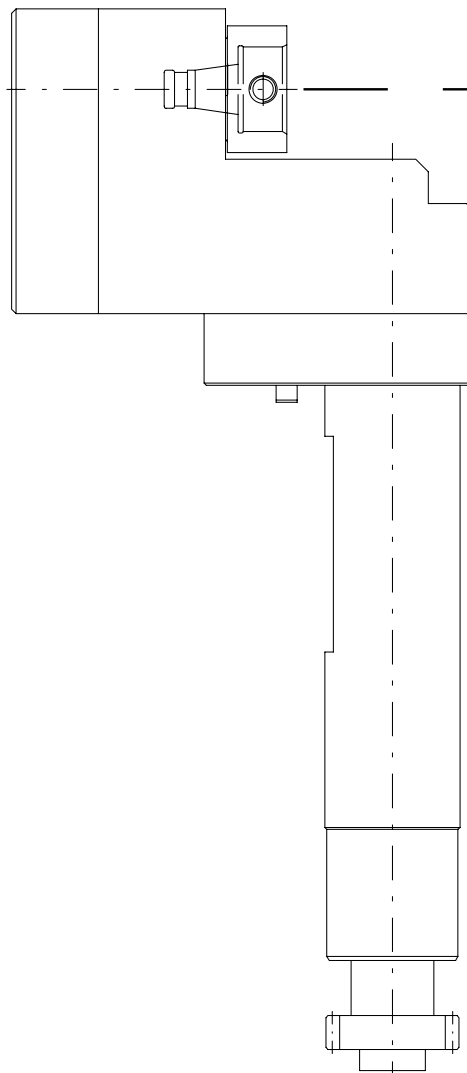
Axial**Radial****WFB - Verlängerungen**

WFB - Extensions

WFB - Prolongations

WFB - Produktübersicht (Auszug)

WFB - Product overview
WFB - Vue d'ensemble de produit

WG 35

WFB

Werkzeugtechnik

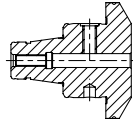

WFB - Weldon / Whistle Notch für Zylinderschäfte DIN 1835 B / E

WFB - Weldon / Whistle Notch for parallel shanks

WFB - Weldon / Whistle Notch pour queues cylindriques

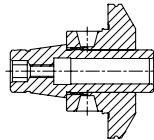

WFB - Schrumpffutter

WFB - Shrink fit chucks

WFB - Mandrins de frettage

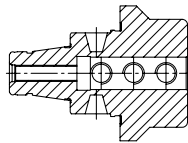

WFB - Bohrstangenhalter

WFB - Boring bar holder

WFB - Porte-outil pour barres d'alésage

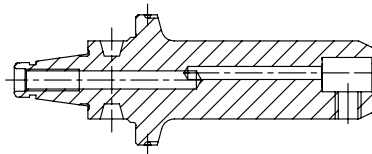

WFB - Klemhalter W-T HORN Supermini® mit IKZ

WFB - Toolholder W-T HORN Supermini® with internal cooling system

WFB - Porte-outil W-T HORN Supermini® avec arrosage central

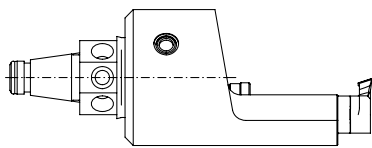

WFB - Klemhalter W-T HORN Mini mit IKZ

WFB - Toolholder W-T HORN Mini with internal cooling system

WFB - Porte-outil W-T HORN Mini avec arrosage central

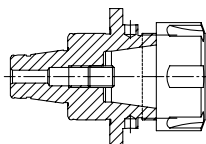

WFB - Spannzangenfutter 8° Typ ER

WFB - Collet chucks 8° type ER

WFB - Mandrins porte-pinces 8° type ER

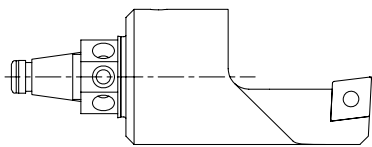

WFB - Drehhalter W-T mit IKZ

WFB - Turning tool holder W-T with internal cooling system

WFB - Rotatif porte-outil W-T avec arrosage central

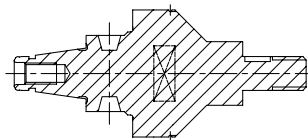

WFB - Sägeblattaufnahmen

WFB - Tool holders for saw blade

WFB - Mandrins pour lame de scie

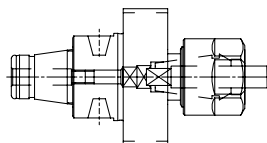

WFB - Softsynchro® mit IKZ

WFB - Softsynchro® with internal cooling system

WFB - Softsynchro® avec arrosage central

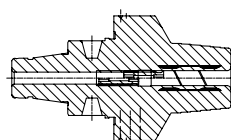

WFB - Hydro-Dehnspannfutter

WFB - Hydraulic expansion chuck

WFB - Mandrin hydraulique



Werkzeugtechnik

WFB - Grundaufnahmen / Voreinstelladapter

WFB - Master shanks
WFB - Module de base

WG 35

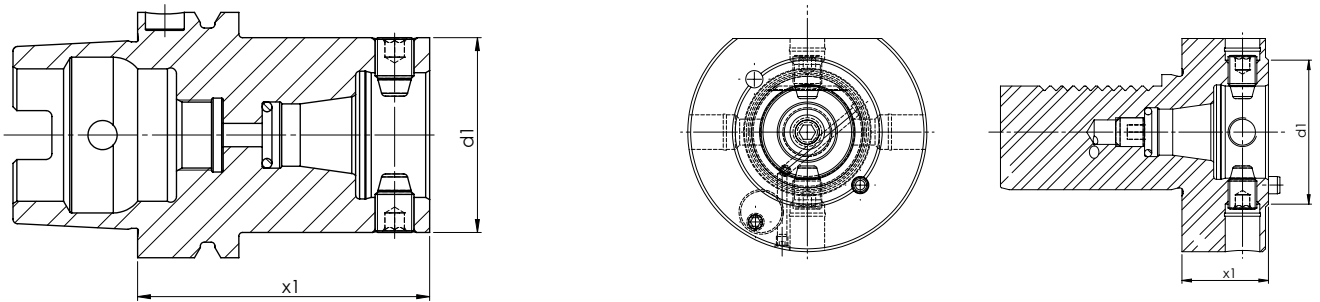

Size Grandeur Größe	Type Type Typ	[mm] d1	[mm] x1	Order no. N° de Code Bestellnummer
---------------------------	---------------------	-------------------	-------------------	---

WFB20-12	HSK 63	30	55	WFB.020.H63
WFB24-16	HSK 63	40	65	WFB.024.H63
WFB32-20	HSK 40	50	40	WFB.032.H40
WFB32-20	HSK 63	50	75	WFB.032.H63
WFB32-20	HSK 100	50	75	WFB.032.H100

Size Grandeur Größe	Type Type Typ	[mm] d1	[mm] x1	Order no. N° de Code Bestellnummer
---------------------------	---------------------	-------------------	-------------------	---

WFB20-12	VDI 30	30	28	WFB.020.V30
WFB24-16	VDI 30	40	28	WFB.024.V30
WFB32-20	VDI 25	50	28	WFB.032.V25
WFB32-20	VDI 30	50	28	WFB.032.V30
WFB32-20	VDI 40	50	30	WFB.032.V40

WFB - Grundaufnahmen / Voreinstelladapter

WFB - Master shanks
WFB - Module de base

WG 35

WF &

Werkzeugtechnik

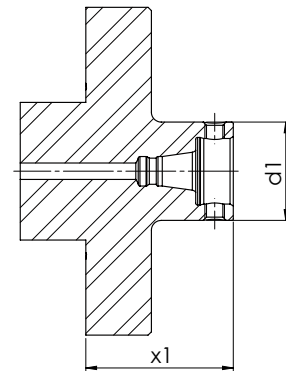
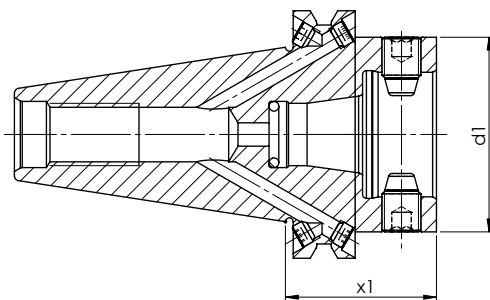

Size	Type	[mm]	[mm]	Order no.
Grandeur	Type			N° de Code
Größe	Typ	d1	x1	Bestellnummer

WFB20-12	SK 40	30	40	WFB.020.S40
WFB20-12	SK 50	30	40	WFB.020.S50
WFB24-16	SK 40	40	40	WFB.024.S40
WFB24-16	SK 50	40	40	WFB.024.S50
WFB32-20	SK 40	50	40	WFB.032.S40
WFB32-20	SK 50	50	40	WFB.032.S50

Size	Type	[mm]	[mm]	Order no.
Grandeur	Type			N° de Code
Größe	Typ	d1	x1	Bestellnummer

WFB20-12	Z01	30	45	WFB.020.SHT.Z01
WFB24-16	Z01	40	45	WFB.024.SHT.Z01
WFB32-20	Z01	50	65	WFB.032.SHT.Z01



Werkzeugtechnik

WFB - Weldon für Zylinderschäfte DIN 1835 B

WFB - Weldon for parallel shanks
WFB - Weldon pour queues cylindriques

WG 35

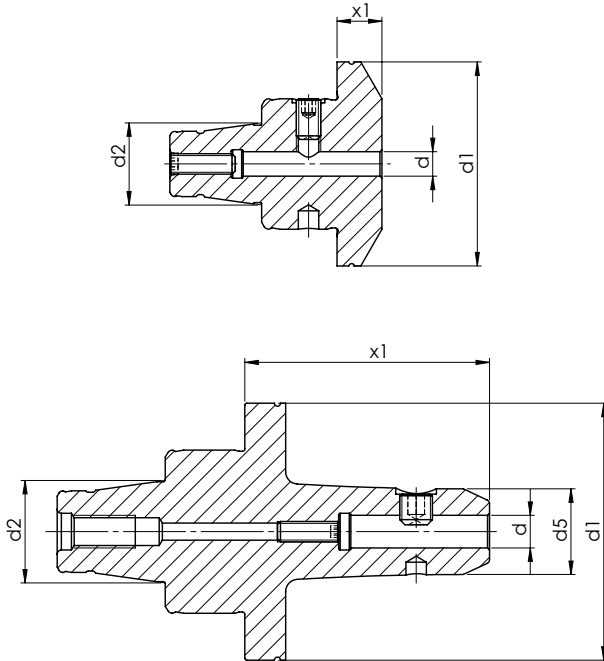

Verwendung: Zum Spannen von Werkzeugen mit Zylinderschaft DIN 1835 Form B.
Lieferumfang: Mit eingebauter Spanschraube

Application: For clamping tools with parallel shank DIN 1835 form B.
Scope of supply: Weldon end mill adaptor incl. locking screw

Application: Pour montage d'outils à queue cylindrique DIN 1835 forme B.
Livraison: Mandrin à pinces Weldon compris vis de serrage

Size Grandeur Größe	[mm] d	[mm] d1	[mm] d2	[mm] d5	[mm] x1	Order no. N° de Code Bestellnummer
WFB 20-12	3	29	12	12	25	WFB.203.025K
WFB 20-12	4	29	12	14	25	WFB.204.025K
WFB 20-12	6	29	12	17	16	WFB.206.016K
WFB 20-12	6	29	12	17	27	WFB.206.027K
WFB 20-12	6	30	12	17	27	WFB.206.027T
WFB 20-12	6	30	12	17	43	WFB.206.043.S
WFB 20-12	6	30	12	25	42,5	WFB.206.043T
WFB 20-12	8	29	12	21	16	WFB.208.016K
WFB 20-12	8	29	12	21	27	WFB.208.027K
WFB 20-12	8	30	12	21	27	WFB.208.027T
WFB 20-12	8	30	12	25	42,5	WFB.208.043T
WFB 20-12	10	29	12	24	37	WFB.210.037K
WFB 20-12	10	30	12	24	37	WFB.210.037T
WFB 20-12	10	30	12	25	42,5	WFB.210.043T

WFB - Weldon für Zylinderschäfte DIN 1835 B

WFB - Weldon for parallel shanks
WFB - Weldon pour queues cylindriques

WG 35



Werkzeugtechnik

Size Grandeur Größe	[mm] d	[mm] d1	[mm] d2	[mm] d5	[mm] x1	Order no. N° de Code Bestellnummer
WFB 20-12	16	30	12	33	55	WFB.216.055
WFB 24-16	6	40	16	11	14	WFB.246.014T
WFB 24-16	6	40	16	17	27	WFB.246.027T
WFB 24-16	8	40	16	21	27	WFB.248.027T
WFB 24-16	10	40	16	17	15	WFB.241.015T
WFB 24-16	10	40	16	24	25	WFB.241.025T
WFB 24-16	12	40	16	27	30	WFB.241.230T
WFB 32-20	4	50	20	14	28	WFB.304.028
WFB 32-20	6	50	20	-	11	WFB.306.011
WFB 32-20	6	50	20	17	28	WFB.306.028T
WFB 32-20	6	50	20	17	40	WFB.306.040
WFB 32-20	6	50	20	17	60	WFB.306.060
WFB 32-20	8	50	20	-	11	WFB.308.011
WFB 32-20	8	50	20	21	28	WFB.308.028T
WFB 32-20	8	50	20	21	40	WFB.308.040
WFB 32-20	8	50	20	21	60	WFB.308.060
WFB 32-20	10	50	20	-	11	WFB.310.011
WFB 32-20	10	50	20	24	25	WFB.310.025T
WFB 32-20	10	50	20	24	35	WFB.310.035
WFB 32-20	10	50	20	24	60	WFB.310.060
WFB 32-20	12	50	20	27	14	WFB.312.014T
WFB 32-20	12	50	20	-	15	WFB.312.015
WFB 32-20	12	50	20	27	35	WFB.312.035
WFB 32-20	12	50	20	27	60	WFB.312.060
WFB 32-20	14	50	20	50	31	WFB.314.031
WFB 32-20	14	50	20	29	60	WFB.314.060
WFB 32-20	16	50	20	50	44	WFB.316.044
WFB 32-20	16	50	20	35	60	WFB.316.060
WFB 32-20	18	50	20	50	44	WFB.318.044
WFB 32-20	18	50	20	35	60	WFB.318.060
WFB 32-20	20	50	20	50	47	WFB.320.047
WFB 32-20	20	50	20	39	60	WFB.320.060
WFB 32-20	25	50	20	47	60	WFB.325.060



Werkzeugtechnik

WFB - WN für Zylinderschäfte DIN 1835 E

WFB - Whistle Notch for parallel shanks
WFB - Whistle Notch pour queues cylindriques

WG 35

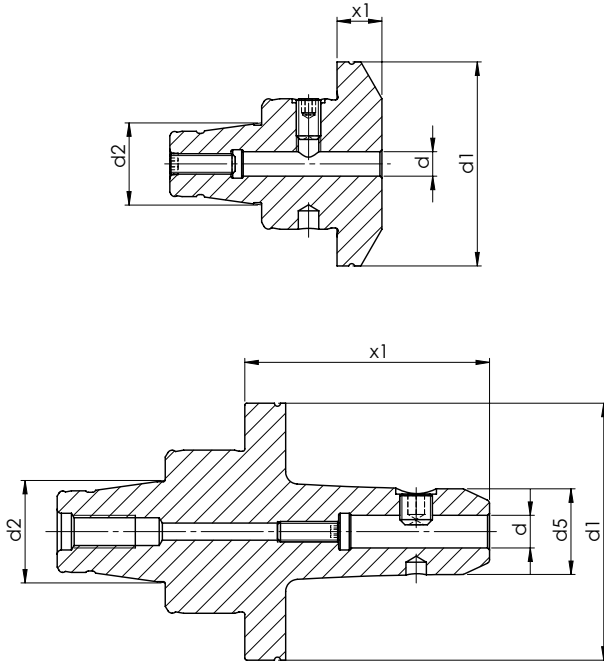

Verwendung: Zum Spannen von Werkzeugen mit Zylinderschaft DIN 1835 Form E
Lieferumfang: Mit eingebauter Spann- und Anschlagschraube

Application: For clamping tools with parallel shank DIN 1835 form E
Scope of supply: Weldon end mill adaptor incl. locking screw and adjusting screw

Application: Pour montage d'outils à queue cylindrique DIN 1835 forme E
Livraison: Mandrin à pinces Weldon compris vis de serrage et vis de réglage

Size Grandeur Größe	[mm] d	[mm] d1	[mm] d2	[mm] d5	[mm] x1	Order no. N° de Code Bestellnummer
WFB20-12	6	30	12	17	27	WFB.206.127T
WFB20-12	6	29	12	17	27	WFB.206.127K
WFB20-12	6	30	12	25	42,5	WFB.206.143T
WFB20-12	8	29	12	21	27	WFB.208.127K
WFB20-12	8	30	12	21	27	WFB.208.127T
WFB20-12	8	30	12	25	42,5	WFB.208.143T
WFB20-12	8	29	12	25	42,5	WFB.208.143K
WFB20-12	10	29	12	24	37	WFB.210.137K
WFB20-12	10	30	12	24	37	WFB.210.137T
WFB20-12	10	30	12	25	42,5	WFB.210.143T
WFB24-16	6	40	16	11	14	WFB.246.114T
WFB24-16	6	40	16	17	27	WFB.246.127T
WFB24-16	8	40	16	21	27	WFB.248.127T
WFB24-16	10	40	16	17	15	WFB.241.115T

WFB - WN für Zylinderschäfte DIN 1835 E

WFB - Whistle Notch for parallel shanks
WFB - Whistle Notch pour queues cylindriques

WG 35



Werkzeugtechnik

Size Grandeur Größe	[mm] d	[mm] d1	[mm] d2	[mm] d5	[mm] x1	Order no. N° de Code Bestellnummer
WFB24-16	10	40	16	24	25	WFB.241.125T
WFB24-16	12	40	16	27	30	WFB.241.330T
WFB32-20	4	50	20	14	28	WFB.304.128
WFB32-20	6	50	20	-	11	WFB.306.111
WFB32-20	6	50	20	17	28	WFB.306.128T
WFB32-20	6	50	20	17	40	WFB.306.140
WFB32-20	6	50	20	17	60	WFB.306.160
WFB32-20	8	50	20	-	11	WFB.308.111
WFB32-20	8	50	20	21	40	WFB.308.140
WFB32-20	8	50	20	21	60	WFB.308.160
WFB32-20	8	50	20	21	28	WFB.308.128T
WFB32-20	10	50	20	-	11	WFB.310.111
WFB32-20	10	50	20	24	25	WFB.310.125T
WFB32-20	10	50	20	24	35	WFB.310.135
WFB32-20	10	50	20	24	60	WFB.310.160
WFB32-20	12	50	20	27	14	WFB.312.114T
WFB32-20	12	50	20	-	15	WFB.312.115
WFB32-20	12	50	20	27	35	WFB.312.135
WFB32-20	12	50	20	27	60	WFB.312.160
WFB32-20	14	50	20	50	31	WFB.314.131
WFB32-20	14	50	20	29	60	WFB.314.160
WFB32-20	16	50	20	50	44	WFB.316.144
WFB32-20	16	50	20	35	60	WFB.316.160.WN
WFB32-20	18	50	20	50	44	WFB.318.144
WFB32-20	18	50	20	35	60	WFB.318.160
WFB32-20	20	50	20	50	47	WFB.320.147
WFB32-20	20	50	20	39	60	WFB.320.160
WFB32-20	25	50	20	47	60	WFB.325.160

WFB - Schrumpffutter

WFB - Shrink fit chucks
WFB - Mandrins de frettage

WG 35

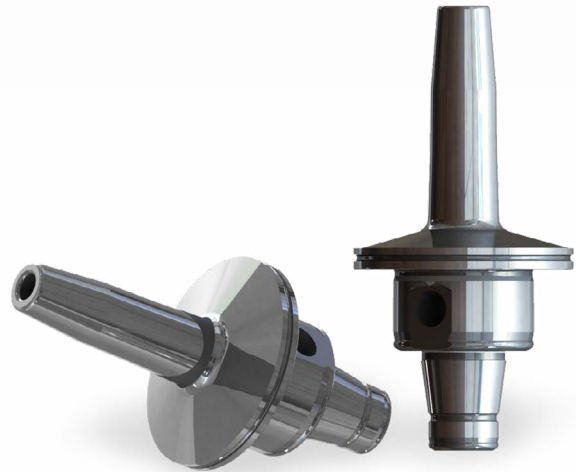
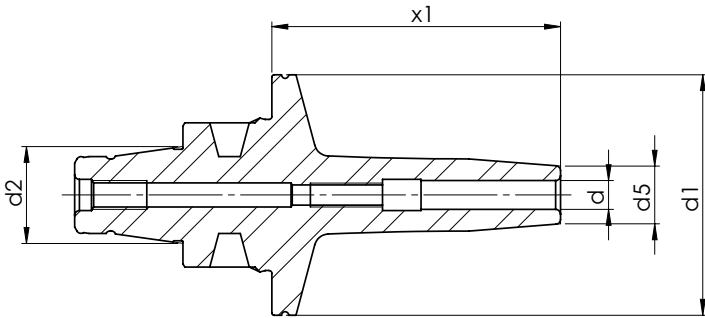
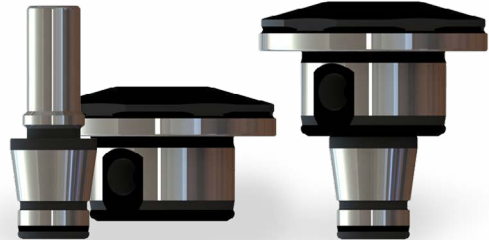
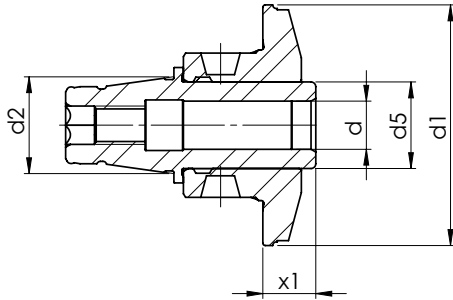

Size Grandeur Größe	[mm] d	[mm] d1	[mm] d2	[mm] d5	[mm] x1	Order no. N° de Code Bestellnummer
WFB20-12	3	30	12	10	37	WFB.203.037.SFR
WFB20-12	3	30	12	10	51	WFB.203.051.SFR
WFB20-12	3	30	12	9	17	WFB.S20.003.017.SF*
WFB20-12	3	29	12	9	17	WFB.S20.003.017.SFK*
WFB20-12	4	30	12	13	35	WFB.204.035.SFR
WFB20-12	4	30	12	12	50	WFB.204.050.SFR
WFB20-12	4	30	12	9	17	WFB.S20.004.017.SF*
WFB20-12	4	29	12	9	17	WFB.S20.004.017.SFK*
WFB20-12	6	30	12	13	32	WFB.206.032.SFR
WFB20-12	6	30	12	15	47	WFB.206.047.SFR
WFB20-12	6	30	12	14	17	WFB.S20.006.017.SF*
WFB20-12	6	30	12	14	27	WFB.S20.006.027.SF*
WFB20-12	6	29	12	14	27	WFB.S20.006.027.SFK*
WFB20-12	8	30	12	15	30	WFB.208.030.SFR
WFB20-12	8	30	12	17	45	WFB.208.045.SFR

* = Zweigeteilte Ausführung / Two split construction / Deux divisé construction

WFB - Schrumpffutter

WFB - Shrink fit chucks
WFB - Mandrins de frettage

WG 35



Werkzeugtechnik

Size	[mm]	[mm]	[mm]	[mm]	[mm]	Order no.
Grandeur						N° de Code
Größe	d	d1	d2	d5	x1	Bestellnummer
WFB20-12	8	30	12	14	20	WFB.S20.008.020.SF*
WFB20-12	8	30	12	14	27	WFB.S20.008.027.SF*
WFB20-12	8	29	12	14	27	WFB.S20.008.027.SFK*
WFB20-12	10	30	12	16	27	WFB.S20.010.027.SF*
WFB20-12	12	30	12	18	35	WFB.2H0.D12.SFR
WFB24-16	3	40	16	13	34	WFB.243.034.SFR
WFB24-16	4	40	16	13	34	WFB.244.034.SFR
WFB24-16	6	40	16	13	30	WFB.246.030.SFR
WFB24-16	8	40	16	14	30	WFB.248.030.SFR
WFB24-16	10	40	16	17	30	WFB.241.030.SFR
WFB32-20	3	50	20	13	37	WFB.303.037SFR
WFB32-20	3	50	20	10	60	WFB.303.060SFR
WFB32-20	3	50	20	-	11	WFB.S32.003.011.SF*
WFB32-20	3	50	20	13	37	WFB.S32.003.037.SF*
WFB32-20	4	50	20	13	35	WFB.304.035.SFR
WFB32-20	4	50	20	12	60	WFB.304.060SFR
WFB32-20	4	50	20	-	11	WFB.S32.004.011.SF*
WFB32-20	5	50	20	13	60	WFB.305.060SFR
WFB32-20	5	50	20	-	11	WFB.S32.005.011.SF*
WFB32-20	6	50	20	13	32	WFB.306.032.SFR
WFB32-20	6	50	20	15	60	WFB.306.060SFR
WFB32-20	6	50	20	-	11	WFB.S32.006.011.SF*
WFB32-20	6	50	20	13	32	WFB.S32.006.032.SF*
WFB32-20	8	50	20	15	30	WFB.308.030.SFR
WFB32-20	8	50	20	17	60	WFB.308.060SFR
WFB32-20	8	50	20	-	11	WFB.S32.008.011.SF*
WFB32-20	8	50	20	15	30	WFB.S32.008.030.SF*
WFB32-20	10	50	20	22	60	WFB.310.060SFR
WFB32-20	10	50	20	18	11	WFB.S32.010.011.SF*
WFB32-20	10	50	20	18	25	WFB.S32.010.025.SF*
WFB32-20	12	50	20	26	60	WFB.312.030.SFR
WFB32-20	12	50	20	25	60	WFB.312.060SFR
WFB32-20	12	50	20	18	11	WFB.S32.012.011.SF*
WFB32-20	12	50	20	18	11	WFB.S32.012.011.SF*
WFB32-20	12	50	20	18	30	WFB.S32.012.030.SF*
WFB32-20	14	50	20	30	60	WFB.314.060.SFR
WFB32-20	14	50	20	27	25	WFB.S32.014.025.SF*
WFB32-20	16	50	20	30	60	WFB.316.060SFR
WFB32-20	16	50	20	27	25	WFB.S32.016.025.SF*
WFB32-20	16	50	20	27	32	WFB.S32.016.032.SF*

* = Zweigeteilte Ausführung / Two split construction / Deux divisé construction

Bedienungsanleitung für zweigeteilte Schrumpffutter System WFB

Operation instructions for two split shrink fit chucks system WFB
 Mode d'emploi pour deux divisé mandrins de frettage système WFB

WG 35

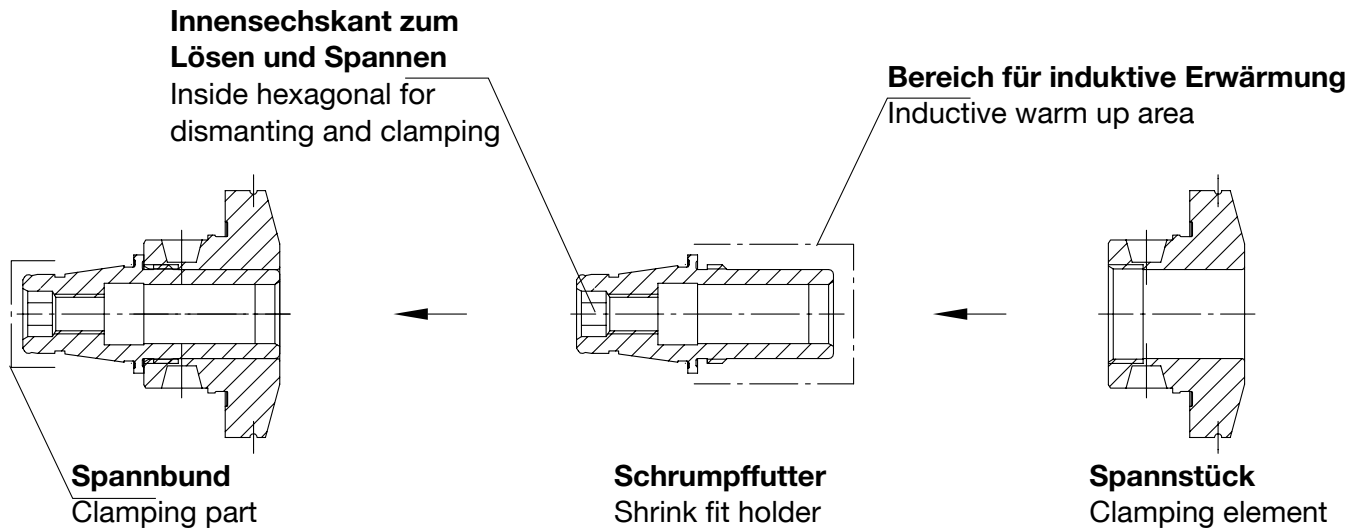

Funktionsweise:

Mode of operation:

1. WFB Schrumpfadapter demontieren. Zum Lösen und Spannen darf nur der im Schrumpffutter eingebrachte Sechskant genutzt werden.

WFB shrink fit chucks disassemble. Please use the inside hexagonal for dismantling and clamping.

2. Schrumpfadapter am Spannbund in Grundaufnahme (Spannzangenfutter) aufnehmen.

Put the shrink adapter with clamping sight in the collet chuck from the machine.

3. Induktiv erwärmen und Schneidwerkzeug einschrumpfen.

Inductive heat up and shrinking cutting tools.

4. Schrumpffutter abkühlen lassen.

Let cool down the shrink adapter.

5. Spannstück und Schrumpffutter zusammen montieren.

Clamping element and shrink fit holder must be mounting together.

Wichtiger Hinweis:

Important information:

WFB Schrumpffutter in kurzer Ausführung bestehen aus dem eigentlichen Schrumpffutter und dem Spannstück. Beide Teile werden in zusammengebauten Zustand ausgeliefert und sind mit der gleichen Kennung beschriftet. Achtung! Nur Teile mit gleicher Kennung dürfen als Adapter montiert werden.

WFB shrink fit holder in short construction consists of shrink fit holder and clamping element. Both element will be delivered in assembled condition and they are marked with the same identification. Attention! Only parts with the same identification may be assembled as adapter.

WFB - Sägeblattaufnahmen

WFB - Tool holders for saw blade
WFB - Mandrins pour lame de scie

WG 35

W&F

Werkzeugtechnik

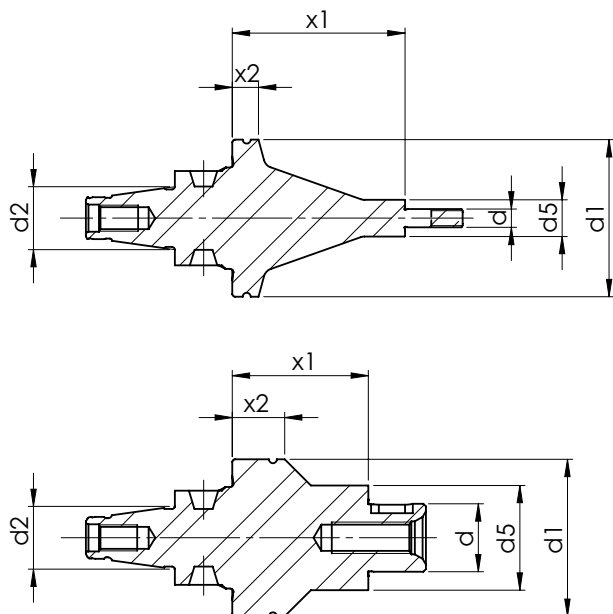

Lieferumfang:

Bei Ø 3,5 mm inkl. 1 St. M3,5x0,6-Mutter,
je 1 St. Fräsdornring 3,5x6,5x1 - 3,5x6,5x2 mm.

Bei Ø 5 mm inkl. 1 St. M5-Mutter,
1 St. Fräsdornring 5x9x1 mm, 2 St. Fräsdornringe 5x9x2 mm.

Bei Ø 8 mm inkl. 1 St. M8x1-Mutter, 1 St. Passfeder 2x2x6 mm,
je 1 St. Fräsdornring 8x14x1 - 8x14x3 - 8x14x4 mm.

Bei Ø 10 mm inkl. 1 St. M10x1-Mutter, 1 St. Passfeder 3x3x7 mm,
je 1 St. Fräsdornring 10x16x0,5 - 10x16x1 - 10x16x3 - 10x16x5 mm.

Bei Ø 13 mm inkl. 1 St. Fräseranzugsschraube, 1 St. Passfeder 4x4x8 mm,
je 1 St. Fräsdornring 13x21x0,5 - 13x22x1 - 13x22x3 - 13x22x5 mm.

Bei Ø 16 mm inkl. 1 St. Fräseranzugsschraube, 1 St. Passfeder 4x4x10 mm,
je 1 St. Fräsdornring 16x25x1 - 16x27x2 - 16x27x3 - 16x27x10 mm.

Bei Ø 22 mm inkl. 1 St. Fräseranzugsschraube, 1 St. Passfeder 6x6x14 mm,
je 1 St. Fräsdornring 22x33x1 - 22x34x2 - 22x34x6 - 22x34x10 mm.

Size	[mm]	[mm]	[mm]	[mm]	[mm]	[mm]	Order no.
Grandeur							N° de Code
Größe	d	d1	d2	d5	x1	x2	Bestellnummer
WFB20-12	3,5	30	12	7	33	5	WFB.035A.2033
WFB20-12	5	30	12	10	33	5	WFB.05A.2033
WFB20-12	8	30	12	15	26	10	WFB.08A.2026
WFB20-12	10	30	12	17	26	10	WFB.10A.2026
WFB20-12	13	30	12	20	26	10	WFB.13A.2026
WFB20-12	16	30	12	24	26	10	WFB.16A.2026
WFB32-20	22	30	20	34	26	10	WFB.22A.2026

WFB - Spannzangenfutter 8° Typ ER

WFB - Collet chucks 8° type ER

WFB - Mandrins porte-pinces 8° type ER

WG 35

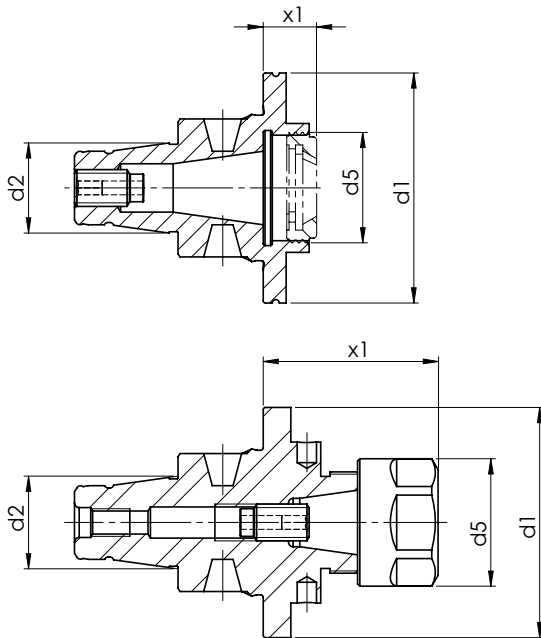

Verwendung: Zur Aufnahme von Werkzeugen mit Zylinderschaft in Spannzangen DIN 6499.

Lieferumfang: Fräsespannfutter mit Spannmutter und Anschlagschraube.

Spannzangen: Siehe Seite 11.35

Application: To hold tools with parallel shank in collets DIN 6499

Scope of supply: Collet chucks with collet nut and adjusting screw.

Collets: See page 11.35

Application: Pour montage d'outils à queue cylindrique en pinces DIN 6499.

Livraison: Mandrins à pinces, écrous de serrage, vis de réglage. **Pinces:** Voir page 11.35

Size Grandeur Größe	Type Type Typ	[mm] d1	[mm] d2	[mm] d5	[mm] x1	Order no. N° de Code Bestellnummer
WFB20-12	ER8 M	30	12	12	25	WFB.208.025MINI
WFB20-12	ER8 M	30	12	12	57	WFB.208.057MINI
WFB20-12	ER11	30	12	16	25	WFB.211.025MINI
WFB20-12	ER11 A	29	12	18	10	WFB.211.A10K
WFB20-12	ER11 A	30	12	18	10	WFB.211.A10T
WFB20-12	ER11	29	12	19	25	WFB.211.025K
WFB20-12	ER11	30	12	19	25	WFB.211.025T
WFB20-12	ER11	30	12	19	45	WFB.211.045T
WFB20-12	ER16 M	30	12	22	28	WFB.216.028MINI
WFB20-12	ER16	29	12	28	28	WFB.216.028K
WFB20-12	ER16	30	12	28	28	WFB.216.028T
WFB20-12	ER16	30	12	28	43	WFB.216.043T
WFB20-12	ER20 M	30	12	28	36	WFB.220.036MINI
WFB20-12	ER20 M	30	12	28	41	WFB.220.041MINI

A* = Innenliegende Spannmutter / Internal collet nut / Ecrous de serrage du dedans

M* = Mini Spannmutter / Mini-collet nut / Mini-écrous de serrage

WFB - Spannzangenfutter 8° Typ ER

WFB - Collet chucks 8° type ER
WFB - Mandrins porte-pinces 8° type ER

WG 35



Werkzeugtechnik

Size Grandeur Größe	Type Type Typ	[mm] d1	[mm] d2	[mm] d5	[mm] x1	Order no. N° de Code Bestellnummer
WFB20-12	ER20 M	30	12	28	46	WFB.220.046MINI
WFB20-12	ER20 M	30	12	28	56	WFB.220.056MINI
WFB20-12	ER20	29	12	34	36	WFB.220.036K
WFB20-12	ER25 M	30	12	35	43	WFB.225.043MINI
WFB20-12	ER25	30	12	42	43	WFB.225.043
WFB24-16	ER11 M	40	16	16	42	WFB.211.042MINI
WFB24-16	ER11	40	16	19	6	WFB.211.006
WFB24-16	ER11	40	16	19	21	WFB.211.021
WFB24-16	ER16 A	40	16	24	16	WFB.216.A16
WFB24-16	ER16	40	16	28	30	WFB.216.030
WFB24-16	ER20 A	40	16	28	30	WFB.220.A30
WFB32-20	ER11 M	50	20	16	67	WFB.311.067MINI
WFB32-20	ER11	50	20	19	24	WFB.311.025T
WFB32-20	ER16 A	50	20	24	10	WFB.316.A10T
WFB32-20	ER16 A	50	20	24	16	WFB.316.A16
WFB32-20	ER16	50	20	28	36	WFB.316.038
WFB32-20	ER16	50	20	28	160	WFB.316.160
WFB32-20	ER20 A	50	20	28	16	WFB.320.A16
WFB32-20	ER25 A	50	20	32	36	WFB.325.A36
WFB32-20	ER25	50	20	42	28	WFB.325.028
WFB32-20	ER25	50	20	42	40	WFB.325.040
WFB32-20	ER32	50	20	50	42	WFB.332.042

A* = Innenliegende Spannmutter / Internal collet nut / Ecrous de serrage du dedans

M* = Mini Spannmutter / Mini-collet nut / Mini-ecrous de serrage



Werkzeugtechnik

WFB - Softsynchro® mit IKZ

WFB - Softsynchro® with internal cooling system
WFB - Softsynchro® avec arrosage central

WG 35

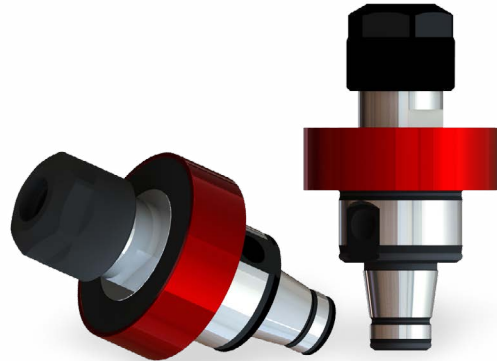
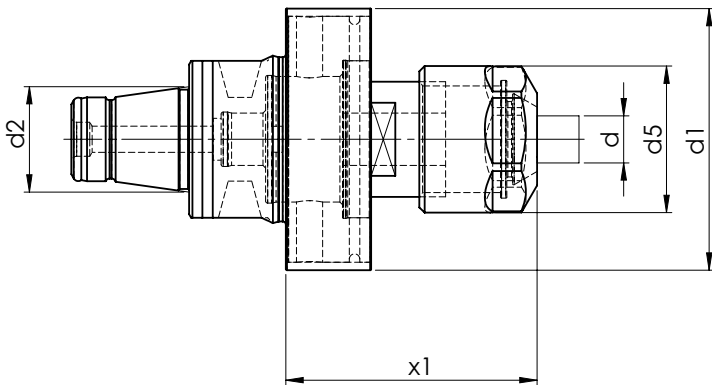

Gewindebohrer DIN374 / DIN376	Gewindebohrer DIN371	Schaft Ø D (mm)	Einstecktiefe E (mm)	Zangen- type
M6	M4	4,5	29	ER-GB
M8	M4,5 - M6	6	31	ER-GB
M10	M7	7	31	ER-GB
-	M8	8	36	ER-GB
M12	-	9	48	ER
-	M10	10	43	ER

Technische Details

Technical specifications

Spannbereich: Ø 4,5 - 10,0 mm für Gewindebohrer M4 - M12.
Range of clamping: Ø 4,5 - 10,0 mm for screw tap M4 - M12.

Längenausgleich auf Druck/Zug: 0,5 mm.
Length compensation on pressure and tension.

Kühlmitteldruck: max. 70 Bar.
Coolant pressure: max. 70 bar.

Kühlmittelzufuhr durch das Zentrum.
Coolant supply through the middle.

Size Grandeur Größe	Type Type Typ	[mm]	[mm]	[mm]	[mm]	Order no. N° de Code Bestellnummer
		d1	d2	d5	x1	
WFB20-12	ER11	30	12	16	32,5	WFB.G20.M8
WFB24-16	ER11	40	16	16	30,5	WFB.G24.M8
WFB32-20	ER16	50	20	28	48	WFB.G32.M12
WFB32-20	ER32	50	20	34	48	WFB.G32.M20

WFB - Hydro-Dehnspannfutter

WFB - Hydraulic expansion chuck
 WFB - Mandrin hydraulique

WG 35



Werkzeugtechnik

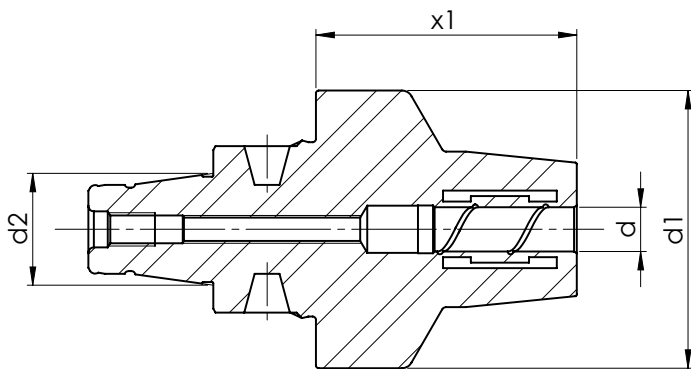

Size	[mm]	[mm]	[mm]	[mm]	Order no.
Grandeur					N° de Code
Größe	d	d1	d2	x1	Bestellnummer
WFB20-12	6	30	12	39	WFB.206.039HDST
WFB20-12	8	30	12	39	WFB.208.039HDST
WFB20-12	10	30	12	39	WFB.210.039HDST
WFB32-20	6	50	20	24	WFB.306.024HDST
WFB32-20	8	50	20	24	WFB.308.024HDST
WFB32-20	10	50	20	29	WFB.310.029HDST
WFB32-20	12	50	20	34	WFB.312.034HDST
WFB32-20	14	50	20	34	WFB.314.034.HDST
WFB32-20	16	50	20	42	WFB.316.042.HDST



Werkzeugtechnik

WFB-Drehhalter W-T mit IKZ

WFB - Turning tool holder W-T with internal cooling system
 WFB - Rotatif porte-outil W-T avec arrosage central

WG 35

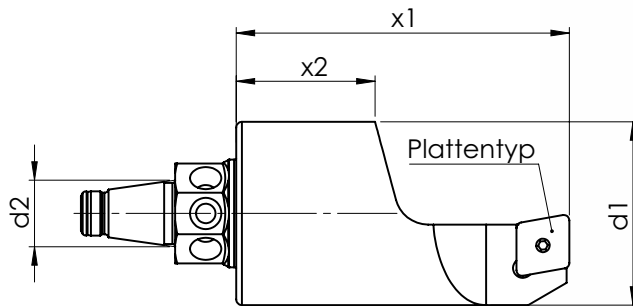

Type	Form
------	------

C09	
D11	
V11	

Size Grandeur Größe	Type Type Typ	[mm] d1	[mm] d2	[mm] x1	[mm] x2	Order no. N° de Code Bestellnummer
WFB20-12	C09	33	12	60	25	WFB.2DH.C09/L
WFB20-12	C09	33	12	60	25	WFB.2DH.C09/R
WFB20-12	D11	33	12	60	25	WFB.2DH.D11/L
WFB20-12	D11	33	12	60	25	WFB.2DH.D11/R
WFB20-12	V11	33	12	60	25	WFB.2DH.V11/L
WFB20-12	V11	33	12	35	10	WFB.2DH.V11.R.X=35
WFB20-12	V11	33	12	60	25	WFB.2DH.V11/R
WFB32-20	C09	50	20	80	25	WFB.3DH.C09/R
WFB32-20	D11	50	20	80	25	WFB.3DH.D11/R
WFB32-20	V11	50	20	80	25	WFB.3DH.V11/R

Lieferung erfolgt ohne Schneidwerkzeuge

Delivery without cutting tools / Livraison sans outils de coupe

WFB-Klemmhalter W-T HORN Mini mit IKZ

WFB - Toolholder W-T HORN Mini with internal cooling system
 WFB - Porte-outil W-T HORN Mini avec arrosage central

WG 35

WF
&

Werkzeugtechnik

Kühlmitteldüse
verstellbar

Coolant nozzle
adjustable

Schneideplatte B114 links

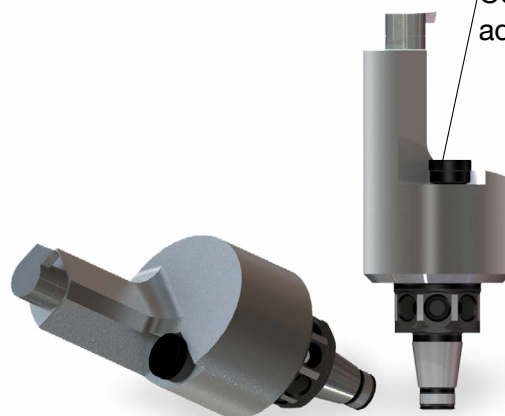
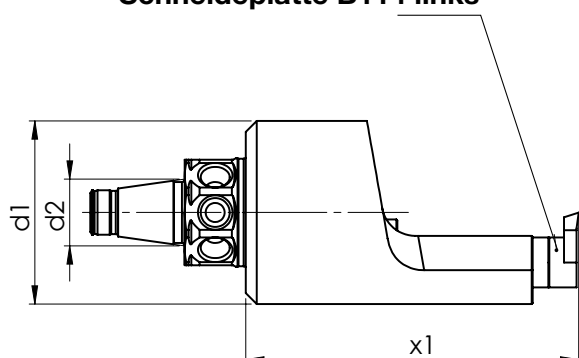

Size Grandeur Größe	Type Type Typ	[mm] d1	[mm] d2	[mm] x1	Order no. N° de Code Bestellnummer
WFB20-12	114	33	12	60	WFB.2HO.114
WFB32-20	114	50	20	80	WFB.3HO.114

Lieferung erfolgt ohne Schneidwerkzeuge

Delivery without cutting tools / Livraison sans outils de coupe



Werkzeugtechnik

WFB-Klemmhalter W-T HORN Supermini® mit IKZ

WFB - Toolholder W-T HORN Supermini® with internal cooling system
 WFB - Porte-outil W-T HORN Supermini® avec arrosage central

WG 35

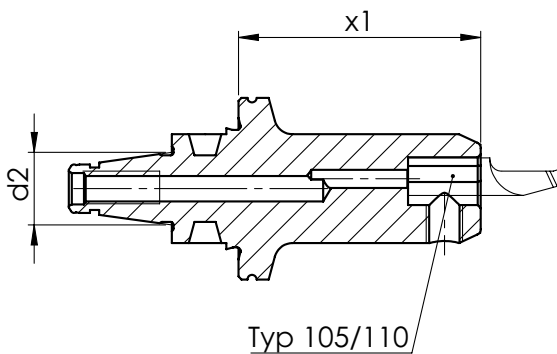

Size Grandeur Größe	Type Type Typ	[mm] d1	[mm] d2	[mm] x1	Order no. N° de Code Bestellnummer
WFB20-12	105	18	12	40	WFB.2HO.105
WFB20-12	105	18	12	55	WFB.2HO.105.055
WFB20-12	110	20	12	40	WFB.2HO.110
WFB32-20	105	50	20	40	WFB.3HO.105
WFB32-20	105	50	20	55	WFB.3HO.105.055
WFB32-20	110	50	20	40	WFB.3HO.110

Lieferung erfolgt ohne Schneidwerkzeuge

Delivery without cutting tools / Livraison sans outils de coupe

WFB - Horn Fräuserschaft mit IKZ

WFB - Horn milling shank with internal cooling
WFB - Horn arbre de coupe avec arrosage central

WG 35

WF
&

Werkzeugtechnik

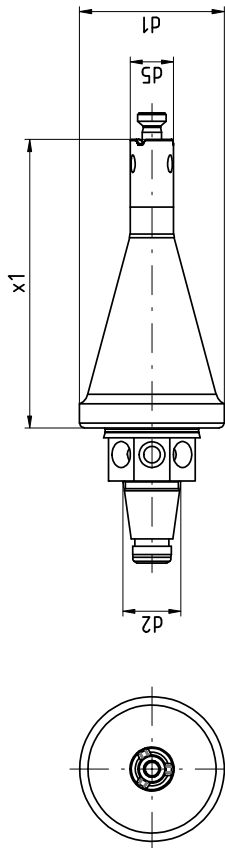

Size Grandeur Größe	Type Type Typ	[mm] d1	[mm] d2	[mm] d5	[mm] x1	Order no. N° de Code Bestellnummer
WFB20-12	311/611	30	12	9	60	WFB.2HO.M311.060
WFB20-12	313/613	30	12	13,3	60	WFB.2HO.M313.060



Werkzeugtechnik

WFB-Bohrstangenhalter

WFB - Boring bar holder
WFB - Porte-outil pour barres d'alésage

WG 35

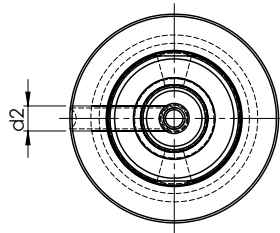
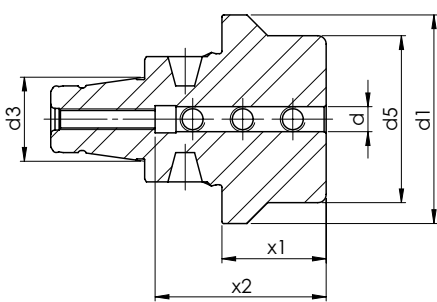

Size Grandeur Größe	[mm]	[mm]	[mm]	[mm]	[mm]	[mm]	[mm]	Order no. N° de Code Bestellnummer
	d	d1	d2	d3	d5	x1	x2	
WFB20-12	3	30	M3	12	18	40	15	WFB.2E0.003
WFB20-12	4	30	M4	12	18	40	15	WFB.2E0.004
WFB20-12	5	30	M5	12	18	40	41	WFB.2E0.005
WFB20-12	6	30	M6	12	18	40	41	WFB.2E0.006
WFB20-12	8	30	M6	12	22	40	41	WFB.2E0.008
WFB20-12	10	30	M6	12	22	40	41	WFB.2E0.010
WFB20-12	12	30	M8	12	30	40	35	WFB.2E0.012
WFB20-12	16	30	M8	12	30	40	35	WFB.2E0.016
WFB20-12	20	30	M8	12	33	40	35	WFB.2E0.020
WFB20-12	1/4"	30	M6	12	18	40	30	WFB.2E0.1/4
WFB20-12	1/8"	30	M3	12	18	40	25	WFB.2E0.1/8
WFB20-12	3/16"	30	M4	12	18	40	25	WFB.2E0.3/16
WFB20-12	3/4"	30	M8	12	33	40	35	WFB.2E0.019
WFB32-20	6	50	M6	20	40	25	41	WFB.3E2.006
WFB32-20	8	50	M6	20	40	25	41	WFB.3E2.008
WFB32-20	10	50	M6	20	40	25	41	WFB.3E2.010
WFB32-20	12	50	M8x1	20	40	25	41	WFB.3E2.012
WFB32-20	16	50	M8x1	20	40	25	41	WFB.3E2.016
WFB32-20	20	50	M8x1	20	50	40	41	WFB.3E2.020
WFB32-20	25	50	M8x1	20	50	55	51	WFB.3E2.025

WFB - Aufsteckfräserdorne mit IKZ

WFB - Milling machine arbors with internal cooling system
 WFB - Mandrins porte-fraises avec arrosage central

WG 35



Werkzeugtechnik

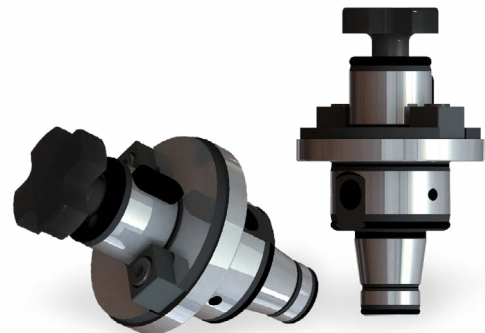
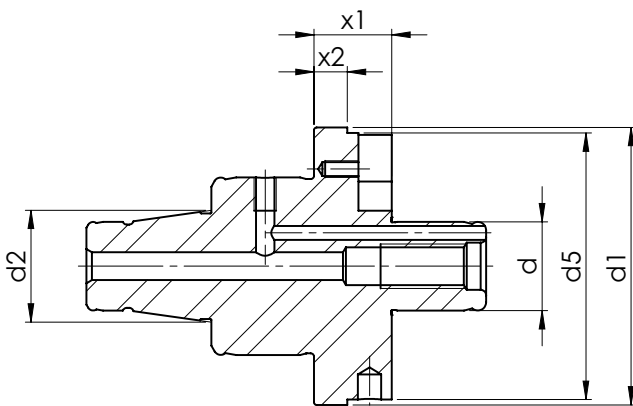

Verwendung: Zur Aufnahme von Fräsern mit Quernut

Lieferumfang: Mit eingebauten Mitnehmersteinen und Fräseranzugschraube

Application: For cutters with key drive

Scope of supply: With driver and cruciform screw

Application: Pour le montage de fraises avec rainures transversales

Livraison: Avec entraînement par tenons et vis de serrage

Size	[mm]	[mm]	[mm]	Smm]	[mm]	mm]	Order no.
Grandeur							N° de Code
Größe	d	d1	d2	d5	x1	x2	Bestellnummer
WFB24-16	16	40	16	30	14	5	WFB.16A.2414
WFB32-20	13	50	20	20	14	6	WFB.13A.3214
WFB32-20	16	50	20	40	14	6	WFB.16A.3214
WFB32-20	22	50	20	48	9	6	WFB.22A.3209T
WFB32-20	22	50	20	48	14	6	WFB.22A.3214
WFB32-20	27	50	20	55	14	6	WFB.27A.3214



Werkzeugtechnik

WFB - Verschlussstopfen

WFB - Closing plug
WFB - Bouchon d'étanchéité

WG 35

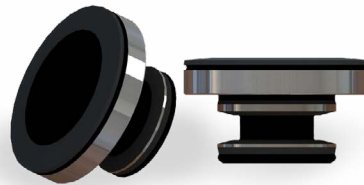
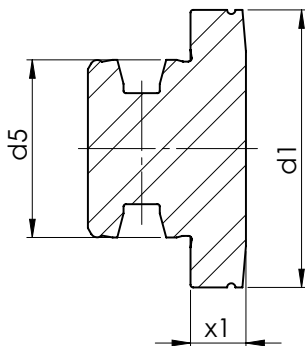

Size Grandeur Größe	[mm] d1	[mm] d2	[mm] x1	Order no. N° de Code Bestellnummer
WFB20-12	29	20	10	WFB.212.000K
WFB20-12	30	20	10	WFB.212.000
WFB24-16	40	24	10	WFB.241.200
WFB32-20	50	32	10	WFB.320.000

WFB - Reduzierungen / Verlängerungen

WFB - Reductions / Extensions
WFB - Réductions / Prolongations

WG 35

WF
&

Werkzeugtechnik

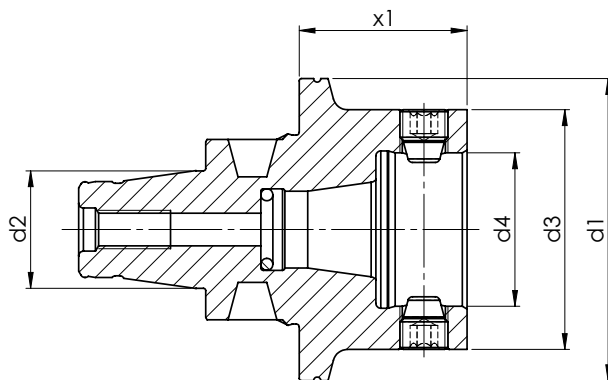

Size Grandeur Größe	[mm]	[mm]	[mm]	[mm]	[mm]	Order no. N° de Code Bestellnummer
	d1	d2	d3	d4	x1	
WFB20-12	30	12	30	12	20	WFB.V20.020
WFB20-12	30	12	30	12	33,5	WFB.V20.033,5
WFB24-16	40	16	30	12	10	WFB.R24.B20
WFB32-20	50	20	30	12	15	WFB.R32.B20
WFB32-20	50	20	40	16	15	WFB.R32.B24
WFB32-20	63	25	40	25	30	WFB.R32.R40



Werkzeugtechnik

WFB - Kontrolldorne

WFB - Test arbors
WFB - Mandrins de contrôle

WG 35

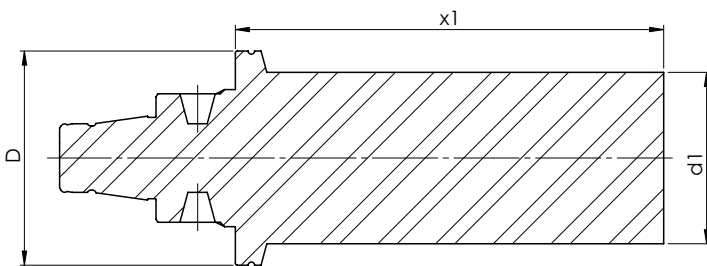

Verwendung: Zur Abnahme von Werkzeugmaschinen gemäß ISO-Empfehlung R230 oder zur Überprüfung der Werkzeugspindel

Application: For machine tools according to ISO recommendations R230 or for testing the tool spindle

Application: Pour la recette technique des machines conforme recommandation ISO R230

Size Grandeur Größe	[mm] D	[mm] d1	[mm] x1	Order no. N° de Code Bestellnummer
WFB20-12	30	16	60	WFB.KD1.060
WFB20-12	29	16	60	WFB.KD1.060K
WFB24-16	40	25	80	WFB.KD2.080
WFB32-20	50	40	100	WFB.KD3.100

WFB - Bohrstangen-Rohlinge

WFB - Boring bar-blanks
WFB - Barres à l'état brut

WG 35

WF
&

Werkzeugtechnik

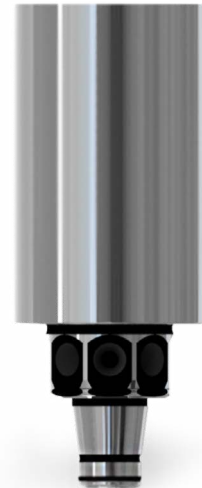
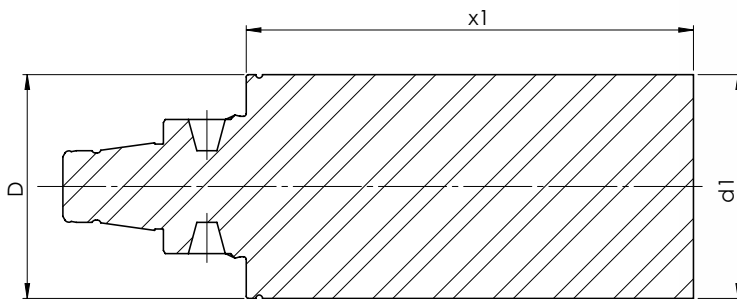

Size Grandeur Größe	[mm] d	[mm] d1	[mm] x1	Order no. N° de Code Bestellnummer
WFB20-12	30	33	60	WFB.R20.060
WFB20-12	30	33	60	WFB.R20.X6S*
WFB24-16	40	45	80	WFB.R24.045.080.SX*
WFB32-20	50	22	60	WFB.R32.022.060.SX*
WFB32-20	50	50	100	WFB.R32.050.100.SX*

* Material: 31CrMoV9

Spannzangen-Sätze mit Holzsockel System ER / ESX

Collets System ER / ESX in wooden board
Pincés de serrage Système ER / ESX en socle de bois

WG 35

WF

Werkzeugtechnik

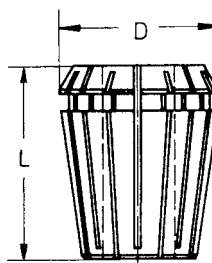

	D	L
426 E	17	27
428 E	21	31,5
430 E	26	34
470 E	33	40
472 E	41	46

ER 40 (3-26) 472 E
23 Spannzangen
4-26 mm Ø, 1 mm gestuft

Art. Nr. 12.326.OHS

Art. Nr. 12.326.OHS.EP

zusätzlich (wie Abbildung)
gegen Mehrpreis
1 Spannzange mit 3 mm Ø

Art. Nr. 12.326.030

Art. Nr. 12.326.030EP

ER 32 (2-20) 470 E
18 Spannzangen
3-20 mm Ø, 1 mm gestuft

Art. Nr. 12.220.OHS

Art. Nr. 12.220.OHS.EP

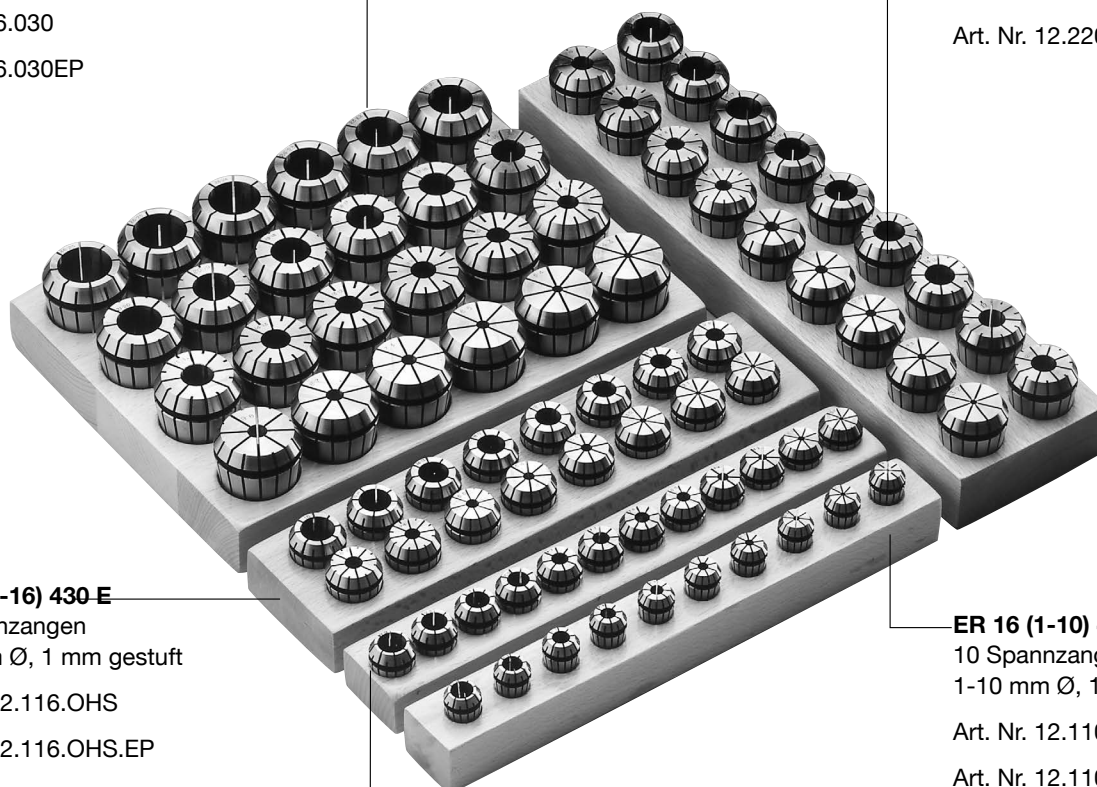

ER 25 (2-16) 430 E
15 Spannzangen
2-16 mm Ø, 1 mm gestuft

Art. Nr. 12.116.OHS

Art. Nr. 12.116.OHS.EP

zusätzlich (wie Abbildung)
gegen Mehrpreis
1 Spannzange mit 1 mm Ø

Art. Nr. 12.116.010

Art. Nr. 12.116.010EP

ER 20 (2-13) 428 E
12 Spannzangen
2-13 mm Ø, 1 mm gestuft

Art. Nr. 12.113.OHS

Art. Nr. 12.113.OHS.EP

ER 16 (1-10) 426 E
10 Spannzangen
1-10 mm Ø, 1 mm gestuft

Art. Nr. 12.110.OHS

Art. Nr. 12.110.OHS.EP



Werkzeugtechnik

Spannzangen System ER / ESX ER11 / ER16 / ER20

Collets System ER / ESX
Pincés de serrage Système ER / ESX

WG 11

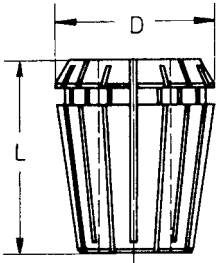

	D	L
424 E	11,5	18
426 E	17	27
428 E	21	31,5

Ø	Order no N° de Cde. Bestellnummer
ER 11 (1 – 8) 424 E	
1,0	12.107.010
1,5	12.107.015
2,0	12.107.020
2,5	12.107.025
3,0	12.107.030
3,5	12.107.035
4,0	12.107.040
4,5	12.107.045
5,0	12.107.050
5,5	12.107.055
6,0	12.107.060
6,5	12.107.065
7,0	12.107.070
8,0	12.107.080*

Ø	Order no N° de Cde. Bestellnummer
ER 16 (1 – 12) 426 E	
1,0	12.110.010
1,5	12.110.015
2,0	12.110.020
2,5	12.110.025
3,0	12.110.030
3,5	12.110.035
4,0	12.110.040
4,5	12.110.045
5,0	12.110.050
5,5	12.110.055
6,0	12.110.060
6,5	12.110.065
7,0	12.110.070
7,5	12.110.075
8,0	12.110.080
8,5	12.110.085
9,0	12.110.090
9,5	12.110.095
10,0	12.110.100
10,5	12.110.105*
11,0	12.110.110*
11,5	12.110.115*
12,0	12.110.120*

Ø	Order no N° de Cde. Bestellnummer
ER 20 (1,0 – 15) 428 E	
1,0	12.113.010*
2,0	12.113.020
3,0	12.113.030
4,0	12.113.040
5,0	12.113.050
6,0	12.113.060
7,0	12.113.070
8,0	12.113.080
9,0	12.113.090
10,0	12.113.100
11,0	12.113.110
12,0	12.113.120
13,0	12.113.130
13,5	12.113.135*
14,0	12.113.140*
14,5	12.113.145*
15,0	12.113.150*

*Sondergröße
Special size
Grandeur speciale

Spannzangen System ER / ESX ER25 / ER32 / ER40

Collets System ER / ESX
Pincas de serrage Système ER / ESX

WG 11



Werkzeugtechnik

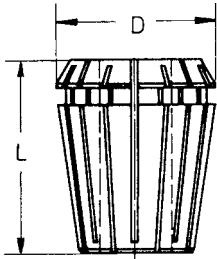

	D	L
430 E	26	34
470 E	33	40
472 E	41	46

Ø	Order no N° de Cde. Bestellnummer
ER 25 (1 – 20) 430 E	
1,0	12.116.010*
2,0	12.116.020
3,0	12.116.030
4,0	12.116.040
5,0	12.116.050
6,0	12.116.060
7,0	12.116.070
8,0	12.116.080
9,0	12.116.090
10,0	12.116.100
11,0	12.116.110
12,0	12.116.120
13,0	12.116.130
14,0	12.116.140
15,0	12.116.150
16,0	12.116.160
16,5	12.116.165*
17,0	12.116.170*
17,5	12.116.175*
18,0	12.116.180*
18,5	12.116.185*
19,0	12.116.190*
19,5	12.116.195*
20,0	12.116.200*

Ø	Order no N° de Cde. Bestellnummer
ER 32 (2 – 22) 470 E	
2,0	12.220.020*
3,0	12.220.030
4,0	12.220.040
5,0	12.220.050
6,0	12.220.060
7,0	12.220.070
8,0	12.220.080
9,0	12.220.090
10,0	12.220.100
11,0	12.220.110
12,0	12.220.120
13,0	12.220.130
14,0	12.220.140
15,0	12.220.150
16,0	12.220.160
17,0	12.220.170
18,0	12.220.180
19,0	12.220.190
20,0	12.220.200
21,0	12.220.210*
22,0	12.220.220*

Ø	Order no N° de Cde. Bestellnummer
ER 40 (3 – 30) 472 E	
3,0	12.326.030*
4,0	12.326.040
5,0	12.326.050
6,0	12.326.060
7,0	12.326.070
8,0	12.326.080
9,0	12.326.090
10,0	12.326.100
11,0	12.326.110
12,0	12.326.120
13,0	12.326.130
14,0	12.326.140
15,0	12.326.150
16,0	12.326.160
17,0	12.326.170
18,0	12.326.180
19,0	12.326.190
20,0	12.326.200
21,0	12.326.210
22,0	12.326.220
23,0	12.326.230
24,0	12.326.240
25,0	12.326.250
26,0	12.326.260
27,0	12.326.270*
28,0	12.326.280*
29,0	12.326.290*
30,0	12.326.300*

*Sondergröße
Special size
Grandeur speciale



Werkzeugtechnik

WFB - Ersatzteile / Zubehör

WFB - Spare parts / Accessories
WFB - Pièces de rechange / Accessoires

WG 11



WFB - Kegeltgewindestifte

Threaded taper pins / Vis coniques filetées

For Size	Order no
Pour Grandeur	N° de Cde.
Für Größe	Bestellnummer

WFB20-12	WFS.M6x0,75.TORX 15 Plus
WFB20-12	WFS.M6x1.TORX
WFB24-16	WFS.M8x1.TORX
WFB32-20	WFS.M10x1x11



Drehmoment-Schraubendreher auf Anfrage lieferbar!

Torque screwdriver on request available!

Tournevis dynamométrique disponible sur demande!

For Size	Order no
Pour Grandeur	N° de Cde.
Für Größe	Bestellnummer

WFB20-12	WFB.020.T15.PLUS
----------	------------------



Drehmomentset

Torque set

For Size	Order no
Pour Grandeur	N° de Cde.
Für Größe	Bestellnummer

WFB20-12/24-16	WF.88103001000
----------------	----------------

Allgemeine Verkaufs- und Lieferbedingungen

General sales terms and delivery conditions
Les conditions de paiement et de livraison

WG 35

WF
&
Werkzeugtechnik

1. Angebot, Vertragsabschluß und Vertragsinhalt

Allen Vertragsabschlüssen, betreffend Lieferung und Leistungen von uns, liegen die nachfolgenden Bedingungen zugrunde. Sie werden vom Besteller mit Auftragserteilung, spätestens mit der Annahme der ersten Lieferung/Leistung anerkannt und gelten für die gesamte Dauer der Geschäftsbeziehung. Abweichende Einkaufsbedingungen des Bestellers gelten nur mit unserer schriftlichen Zustimmung.

Der Vertrag kommt erst mit unserer schriftlichen Bestätigung und entsprechend deren Inhalt und durch Lieferung/Leistung zustande. Erfolgt ohne eine Bestätigung unverzüglich Lieferung/Leistung, so gilt die Rechnung gleichzeitig als Auftragsbestätigung.

2. Bestellwert

Bei einem Bestellwert unter € 100,- kommen keine Rabatte in Anrechnung. Der Mindestbestellwert beträgt € 60,- netto.

3. Preis und Zahlung

Die Preise gelten mangels besonderer Vereinbarung ab Werk einschl. Verladung im Werk, jedoch ausschließlich Verpackung. Zu den Preisen kommt die Mehrwertsteuer in der jeweiligen gesetzlichen Höhe hinzu.

Mangels besonderer Vereinbarung ist die Zahlung ohne jeden Abzug frei Zahlstelle des Lieferanten innerhalb von 30 Tagen nach Rechnungsdatum (auch bei Teillieferung) zu leisten.

Die Zurückhaltung von Zahlungen oder die Aufrechnung wegen etwaiger vom Lieferer bestrittener Gegenansprüche des Bestellers sind nicht statthaft.

4. Eigentumsvorbehalt

Die gelieferten Waren bleiben unser Eigentum (Vorbehaltsware) bis zur Erfüllung sämtlicher uns gegen den Besteller aus der Geschäftsverbindung zustehenden Ansprüche.

Die Verarbeitung der Vorbehaltsware ist dem Besteller im Rahmen des regelmäßigen Geschäftsbetriebs gestattet. Die Verarbeitung der Ware erfolgt für uns. Wir erwerben in allen Fällen das Eigentum an den neu hergestellten Sachen; eine Verpflichtung entsteht für uns hieraus nicht. Der Besteller hat die in unserem (Mit-)Eigentum stehenden Waren für uns unentgeltlich zu verwahren. Bei Verarbeitung mit Waren an denen wir kein Eigentum besitzen erwerben wir Miteigentum an den neu hergestellten Sachen nach dem Verhältnis des Rechnungswertes der Vorbehaltsware zu den anderen verarbeiteten Gegenständen. Sollte unser Eigentum dennoch untergehen und der Besteller (Mit-)Eigentümer werden, so überträgt er bereits jetzt sein Eigentum nach dem vorab bezeichneten Wertverhältnis als Sicherheit auf uns.

Der Besteller ist zu Weiterveräußerung der Vorbehaltsware im Rahmen seines regelmäßigen Geschäftsbetriebs nur unter der Bedingung berechtigt, dass er sich seinerseits das Eigentum bis zur vollständigen Zahlung des Kunden vorbehält. Die Veräußerungsermächtigung erlischt automatisch bei einem fruchtlosen Zwangsvollstreckungsversuch beim Besteller, sowie bei Stellung eines Antrags auf Eröffnung des Insolvenzverfahrens über das Vermögen des Bestellers. Andere Verfügungen über die Vorbehaltsware, insbesondere Verpfändung und Sicherungsübertragung sind unzulässig.

Der Besteller tritt bereits jetzt alle aus der Weiterveräußerung der Vorbehaltsware in verarbeitetem und unverarbeitetem Zustand entstehenden Forderungen mit allen Nebenrechten – einschließlich etwaiger Saldoforderungen – sicherungshalber an uns ab, ohne dass es noch späterer besonderer Erklärungen bedarf. Veräußert der Besteller verarbeitete, verbundene oder vermischte Vorbehaltsware, ohne dass eine Einzelpreisvereinbarung für die Vorbehaltsware besteht, so tritt der Besteller uns mit Vorrang vor der übrigen Forderung denjenigen Teil der Gesamtpreisforderung ab, der dem von uns in Rechnung gestellten Preis der Vorbehaltsware entspricht.

Der Besteller ist verpflichtet uns unverzüglich über Zwangsvollstreckungsmaßnahmen Dritter in die Vorbehaltsware und in deren sonstige Sicherheiten unter Übergabe der für den Widerspruch notwendigen Unterlagen zu unterrichten.

Der Besteller ist vorbehaltlich des jederzeit möglichen Widerrufs berechtigt, die an uns abgetretenen Forderungen im regelmäßigen Geschäftsbetrieb einzuziehen. Von dieser Ermächtigung nicht erfasst ist die Abtretung der aus der Weiterveräußerung der Waren resultierenden Forderungen an ein Factoring-Institut im Rahmen eines sog. „echten“ Factorings unter Übernahme des Delkredererisikos. Vorsorglich tritt der Besteller seine Rechte gegen das Factoring-Institut auf Auszahlung des Factoring Erlöses an uns ab und verpflichtet sich, dem Factoring-Institut unverzüglich nach Rechnungsstellung durch uns diese Abtretung anzuzeigen. Wir werden von unserer Einziehungsbefugnis keinen Gebrauch machen, solange der Besteller seinen Zahlungsverpflichtungen vereinbarungsgemäß nachkommt.

Der Besteller verpflichtet sich bei Zugriffen Dritter auf die Vorbehaltsware, wie z.B. Pfändungen, uns sofort zu unterrichten um uns die Durchsetzung unserer Eigentumsrechte zu ermöglichen und auf unser daran bestehendes Eigentum hinzuweisen.

5. Lieferzeit

Angegebene Lieferzeiten sind, sofern nicht individuell vereinbart, unverbindlich.

6. Mängelrüge

Erkennbare Mängel sind unverzüglich nach Empfang der Lieferung/Leistung, versteckte Mängel unverzüglich nach Entdeckung schriftlich zu rügen. Mängelrüge ist verspätet, wenn sie nicht spätestens 8 Tage nach Empfang der Lieferung/Leistung bzw. bei versteckten Mängeln nach Entdeckung des Mangels bei uns eingegangen ist. Wenn eine Mängelrüge begründet geltend gemacht wird, dürfen Zahlungen nur im Umfang zurückgehalten werden, die in einem angemessenen Verhältnis zu dem aufgetretenen Mangel stehen.

7. Gewährleistung und Haftung

Wir haften für rechtzeitig gerügte Mängel, zu denen auch das Fehlen zugesicherter Eigenschaften gehört, wie folgt:

– Alle diejenigen Teile sind unentgeltlich nach billigem Ermessen nach Wahl des Lieferanten nachzubessern oder neu zu liefern, die sich innerhalb von 6 Monaten (bei Mehrschichtenbetrieb innerhalb von 3 Monaten) seit Lieferung infolge eines vor dem Gefahrenübergang liegenden Umstandes – insbesondere wegen fehlender Bauart, schlechter Werkstoffe oder mangelhafter Ausführung – als nicht unerheblich beeinträchtigt herausstellen. Mehrere Nachbesserungsversuche sind zulässig. Ersetzte Teile werden unser Eigentum.

Für Mängel des vom Besteller angelieferten Materials haften wir nicht. Für wesentliche Fremderzeugnisse beschränkt sich unsere Haftung auf die Abtretung der Haftungsansprüche, die uns gegen den Lieferer des Fremderzeugnisses zustehen.

Bei Fertigung nach Zeichnung des Bestellers haften wir nur für zeichnungsgemäße Ausführung.

– Es wird keine Gewähr übernommen für Schäden, die aus nachfolgenden Gründen entstanden sind:

Ungeeignete und unsachgemäße Verwendung, fehlerhafter Montage bzw. Inbetriebsetzung durch den Besteller oder Dritte, natürliche Abnutzung, fehlerhafte oder nachlässige Behandlung, ungeeignete Betriebsmittel, chemische, elektrochemische oder elektrische Einflüsse, sofern sie nicht auf unser Verschulden zurückzuführen sind. Unsere Gewährleistungspflicht entfällt, wenn von Seiten des Bestellers oder Dritter ohne unsere Zustimmung Instandsetzungen, Beschädigungen oder Änderungen vorgenommen werden, die mit dem geltend gemachten Mangel in Zusammenhang stehen.

8. Rücknahme von Waren

Waren werden nur nach besonderer Vereinbarung zurück genommen – vorbehaltlich folgender Bedingungen:

Die Ware muss in fabriktuem Zustand und aus der laufenden Produktion sein. Eine Lieferschein- oder Rechnungskopie muss der Rücksendung beiliegen.

Für Rücksendungen, die der Besteller zu vertreten hat, wird eine Bearbeitungsgebühr von 15%, mindestens jedoch € 30,- in Abzug gebracht.

Sonderaufnahmen oder speziell auf Kundenwunsch beschriftete Artikel sind vom Umtausch bzw. Rückgabe ausgeschlossen.

9. Haftung für Nebenpflichten, sonstige Haftung

Unsere anwendungstechnische Beratung in Wort und Schrift sowie Vorschläge, Berechnungen, Projektierungen usw. sollen dem Besteller lediglich die bestmögliche Verwendung unserer Produkte erläutern. Sie befreit den Besteller nicht von seiner Verpflichtung, sich durch eigene Prüfung von der Eignung unserer Produkte für den von ihm beabsichtigten Zweck zu überzeugen.

10. Schutzrecht, Werkzeug

An allen unseren Angeboten und Lieferungen beigefügten Abbildungen, Skizzen, Zeichnungen, Lehren, Muster usw. behalten wir uns Eigentums- und Urheberrechte vor. Sie dürfen Dritten ohne unsere ausdrückliche Genehmigung nicht zugänglich gemacht werden. Vervielfältigungen und Nachahmungen sind verboten.

Der Besteller übernimmt für die von ihm beizubringenden Unterlagen, Pläne, Muster oder dergleichen die alleinige Verantwortung. Der Besteller hat dafür einzustehen, dass von ihm vorgelegte Ausführungszeichnungen in Schutzrechte Dritter nicht eingreifen.

11. Erfüllungsort

Erfüllungsort ist 72663 Großbettlingen.

12. Gerichtsstand

Gerichtsstand ist der Sitz des Lieferanten.

13. Änderungsvorbehalt und Teilnichtigkeit

Wir erklären dem Besteller ausdrücklich unsere Bereitschaft, im Wege des freien gegenseitigen Aushandelns die Vertragsklauseln inhaltlich auszugestalten. Sollte eine Bestimmung unserer Verkaufs- und Lieferbedingungen aus irgend einem Grunde nichtig sein, bleibt die Geltung der übrigen Bestimmungen hiervon unberührt. Anstelle einer unwirksamen Regelung gilt das gesetzlich Zulässige.

Stand: April 2007

Modulare Aggregatetechnik

Citizen



Katalog CI-02

Modulare Aggregatetechnik

DMG MORI



Katalog GS-02

Modulare Aggregatetechnik

Hanwha



Katalog HA-02

Modulare Aggregatetechnik

Maier



Katalog MA-02

Modulare Aggregatetechnik

Star



Katalog ST-02

Modulare Aggregatetechnik

TORNOS



Katalog TO-03

Modulare Aggregatetechnik

Gesamtkatalog



Katalog GS-01

Modulare Aggregatetechnik

Doosan



Katalog DO-01

Modulare Aggregatetechnik

Mazak



Katalog MZ-01

Modulare Aggregatetechnik

Mori Seiki



Katalog MS-01

Modulare Aggregatetechnik

Okuma



Katalog OK-01

Modulare Aggregatetechnik

WFB-Adapter



Katalog WFB-01

Modulare Aggregatetechnik

Haas



Katalog HA-01

Modulare Aggregatetechnik

WFE/SHT



Katalog WF-02

Modulare Drehhalter

WF-MICRO



Katalog MI-02

W&F
Werkzeugtechnik GmbH
 Kantstraße 4
 72663 Großbettlingen

T +49 (0) 7022/4058-0
 F +49 (0) 7022/4058-58
 info@wf-werkzeugtechnik.de
 wf-werkzeugtechnik.de